

# AIR CONDITIONER

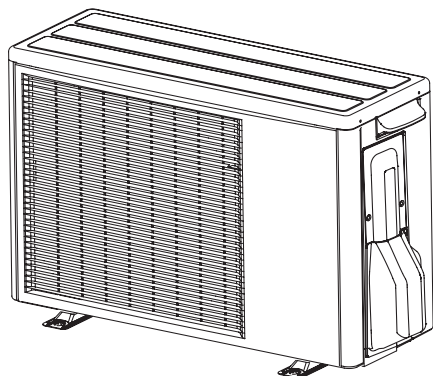

## INSTALLATION MANUAL

OUTDOOR UNIT (Split Type)

For authorized service personnel only.

English

## INSTALLATIONSVEJLEDNING

UDENDØRSENHED (split type)

Kun til autoriseret servicepersonale.

Danish

## ASENNUSOHJE

ULKOYKSIKKÖ (jaettu)

Vain valtuutetuille huoltohenkilöille.

Finnish

## INSTALLASJONSVEILEDNING

UTENDØRSENHET (Delt utgave)

Kun for autorisert servicepersonell.

Norwegian,

## INSTALLATIONSHANDBOK

UTOMHUSENHET (Split-typ)

Endast för auktoriserad servicepersonal.

Swedish

## INSTRUKCJA MONTAŻU

URZĄDZENIE ZEWNĘTRZNE (typu split)

Do użytku wyłącznie przez autoryzowany personel obsługi technicznej.

Polish

**Contents**

1. SAFETY PRECAUTIONS.....	2
2. ABOUT THE UNIT.....	2
3. SELECTING AN INSTALLATION LOCATION.....	3
4. INSTALLATION.....	4
5. PUMP DOWN.....	5

**Notes:**

- This manual describes how to install the outdoor unit only. To install the indoor unit, refer to the installation manual included with the indoor unit.
- Be sure to read this manual thoroughly before the installation.
- Hand this manual, together with the operating manual, to the customer. Request the customer to keep them on hand for future use, such as for relocating or repairing the unit.
- After the installation, explain correct operation to the customer by using the operating manual.

**1. SAFETY PRECAUTIONS**

The warnings and precautions indicated in this manual contain important information pertaining to your safety. Be sure to observe them.

 <b>WARNING</b>	This mark indicates procedures which, if improperly performed, might lead to the death or serious injury of the user.
--	---

 <b>CAUTION</b>	This mark indicates procedures which, if improperly performed, might possibly result in personal harm to the user, or damage to property.
---	---

 <b>WARNING</b>
For the air conditioner to operate satisfactorily, install it as outlined in this installation manual.
Installation work must be performed in accordance with national wiring standards by authorized personnel only.
Never touch electrical components immediately after the power supply has been turned off. Electrical shock may occur. After turning off the power, always wait 5 minutes or more before touching electrical components.
Do not turn ON the power until all work has been completed. Turning ON the power before the work is completed can cause serious accidents such as electric shock or fire.
If refrigerant leaks while work is being carried out, ventilate the area. If the refrigerant comes in contact with a flame, it produces a toxic gas.
Connect the indoor unit and outdoor unit with the air conditioner piping and cable available standards parts. This installation manual describes the correct connections using the installation set available from our standard parts.
Do not use an extension cable.
Do not purge the air with refrigerants but use a vacuum pump to vacuum the installation.
There is not extra refrigerant in the outdoor unit for air purging.

 <b>CAUTION</b>
When installing pipes shorter than 3 m, sound of the outdoor unit will be transferred to the indoor unit, which will cause large operating sound or some abnormal sound.
This unit must be installed by qualified personnel with a capacity certificate for handling refrigerant fluids. Refer to regulation and laws in use on installation place.
The unit must be correctly grounded and the supply line must be equipped with a differential breaker in order to protect the persons.
The units are not explosion proof and therefore should not be installed in explosive atmosphere.
This unit contains no user-serviceable parts. Always consult authorized service personnel to repairs.
Children should be monitored to ensure they do not play with the device.
This product is not intended to be used by people (including children) with physical, sensory or mental disability, or persons lacking experience or knowledge unless they have been given by the through a person responsible for their safety, supervision or instruction concerning the use of the device.

 <b>CAUTION</b>
Do not touch the aluminum fins of heat exchanger built-in the indoor or outdoor unit to avoid personal injury when you install or maintain the unit.
Do not place any other electrical products or household belongings under indoor unit or outdoor unit. Dripping condensation from the unit might get them wet, and may cause damage or malfunction of your property.

- Be careful not to scratch the air conditioner when handling it.
- The maximum length of the piping is 20 m. The maximum height difference of the piping is 15 m, if the units are further apart than these, correct operation can not be guaranteed.

**2. ABOUT THE UNIT**

**2.1. Precautions for using R410A refrigerant**

The basic installation work procedures are the same as conventional refrigerant (R22) models. However, pay careful attention to the following points:
Since the working pressure is 1.6 times higher than that of conventional refrigerant (R22) models, some of the piping and installation and service tools are special. (See the table below.) Especially, when replacing a conventional refrigerant (R22) model with a new refrigerant R410A model, always replace the conventional piping and flare nuts with the R410A piping and flare nuts.
Models that use refrigerant R410A have a different charging port thread diameter to prevent erroneous charging with conventional refrigerant (R22) and for safety. Therefore, check beforehand. [The charging port thread diameter for R410A is 1/2 inch.]
Be more careful that foreign matter (oil, water, etc.) does not enter the piping than with refrigerant (R22) models. Also, when storing the piping, securely seal the opening by pinching, taping, etc.
When charging the refrigerant, take into account the slight change in the composition of the gas and liquid phases. And always charge from the liquid phase where refrigerant composition is stable.

**2.2. Special tools for R410A**

 <b>WARNING</b>
<b>Do not use the existing (for R22) piping and flare nuts.</b> If the existing materials are used, the pressure inside the refrigerant cycle will rise and cause failure, injury, etc. (Use the special R410A materials.)
<b>When installing and relocating the air conditioner, do not mix gases other than the specified refrigerant (R410A) to enter the refrigerant cycle.</b> If air or other gas enters the refrigerant cycle, the pressure inside the cycle will rise to an abnormally high value and cause failure, injury, etc.

Tool name	Contents of change
<b>Gauge manifold</b>	Pressure is high and cannot be measured with a conventional (R22) gauge. To prevent erroneous mixing of other refrigerants, the diameter of each port has been changed. It is recommended the gauge with seals -0.1 to 5.3 MPa (-1 to 53 bar) for high pressure. -0.1 to 3.8 MPa (-1 to 38 bar) for low pressure.
<b>Charge hose</b>	To increase pressure resistance, the hose material and base size were changed.
<b>Vacuum pump</b>	A conventional vacuum pump can be used by installing a vacuum pump adapter.
<b>Gas leakage detector</b>	Special gas leakage detector for HFC refrigerant R410A.

**Copper pipes**

It is necessary to use seamless copper pipes and it is desirable that the amount of residual oil is less than 40 mg/10 m. Do not use copper pipes having a collapsed, deformed or discolored portion (especially on the interior surface). Otherwise, the expansion valve or capillary tube may become blocked with contaminants.  
As an air conditioner using R410A incurs pressure higher than when using R22, it is necessary to choose adequate materials.  
Thicknesses of copper pipes used with R410A are as shown in Table1. Never use copper pipes thinner than 0.8 mm even when it is available on the market.

**Thicknesses of Annealed Copper Pipes**

		Thickness (mm)	
Nominal diameter (in.)	Outer diameter (mm)	R410A	[ref.] R22
1/4	6.35	0.80	0.80
3/8	9.52	0.80	0.80
1/2	12.70	0.80	0.80

### 2.3. Additional charge

#### CAUTION

When adding refrigerant, add the refrigerant from the charging port at the completion of work.

The maximum length of the piping is 20 m. If the units are further apart than this, correct operation can not be guaranteed.

Refrigerant suitable for a piping length of 15 m is charged in the outdoor unit at the factory. When the piping is longer than 15 m, additional charging is necessary. For the additional amount, see the table below.

Pipe length	15 m	20 m	Rate
Additional refrigerant	None	+100 g	20 g/m

Between 15 m and 20 m, when using a connection pipe other than that in the table, charge additional refrigerant with 20 g/1 m as the criteria.

### 2.4. Electrical requirements

The rated voltage of this product is **230 V AC 50 Hz.**

#### WARNING

Before turning on the power, check if the voltage is within the 220 V -10 % to 240 V +10 % range.

Always use a special branch circuit and install a special receptacle to supply power to the room air conditioner.

Use a circuit breaker and receptacle matched to the capacity of the air conditioner.

Do not extend the power cable.

Perform wiring work in accordance with standards so that the air conditioner can be operated safely and positively.

Install a leakage circuit breaker in accordance with the related laws and regulations and electric company standards.

Always use a separate power supply line protected by a circuit breaker operating on all wires with a distance between contact of 3 mm for this unit.

#### CAUTION

The power source capacity must be the sum of the air conditioner current and the current of other electrical appliances. When the current contracted capacity is insufficient, change the contracted capacity.

When the voltage is low and the air conditioner is difficult to start, contact the power company the voltage raised.

Electric wire size and fuse capacity for each model are as follows:

Indoor unit capacity [Btu/h class]	9,000	12,000	14,000	
			MAX.	4.0
Power supply cable [mm <sup>2</sup> ]	1.5	1.5	MIN.	3.5
Connection cable [mm <sup>2</sup> ]	1.5	1.5	1.5	
Fuse capacity [A]	15	15	20	

- Use conformed cable with Type 60245 IEC 57.
- Install all electrical works in accordance to the national standard.
- Install the circuit breaker nearby the units.

## 3. SELECTING AN INSTALLATION LOCATION

With considering written conditions below, select an appropriate installing location in consultation with the customer.

#### WARNING

Securely install the outdoor unit at a location that can withstand the weight of the unit. Otherwise, the outdoor unit may fall and cause injury.

Be sure to install the outdoor unit as prescribed, so that it can withstand earthquakes or strong winds. Improper installation can cause the unit to topple or fall, or other accidents.

#### CAUTION

Do not install the outdoor unit in the following areas:

- Area with high salt content, such as at the seaside. It will deteriorate metal parts, causing the parts to fail or the unit to leak water.
- Area filled with mineral oil or containing a large amount of splashed oil or steam. It will deteriorate plastic parts, causing the parts to fail or the unit to leak water.
- Area that generates substances that adversely affect the equipment, such as sulfuric gas, chlorine gas, acid, or alkali. It will cause the copper pipes and brazed joints to corrode, which can cause refrigerant leakage.
- Area containing equipment that generates electromagnetic interference. It will cause the control system to malfunction, preventing the unit from operating normally.
- Area that can cause combustible gas to leak, contains suspended carbon fibers or flammable dust, or volatile inflammables such as paint thinner or gasoline. If gas leaks and settles around the unit, it can cause a fire.
- Area that has heat sources, vapors, or the risk of the leakage of flammable gas in the vicinity.
- Area where small animals may live. It may cause failure, smoke or fire if small animals enter and touch internal electrical parts.
- Area where animals may urinate on the unit or ammonia may be generated.

In places where the outdoor temperature drops to 0 °C or lower, the drain water may freeze and may stop up the drain or cause other outdoor unit trouble. Therefore take measures so that the drain water will not freeze and clog the drain.

Set up the outdoor unit in a high place, and do not arrange the frame of installed stand under the drain port. Because the water dropped from the drain port repeats freezing and accumulating, and may block the drain port.

In the area with heavy snowfall, if the intake and outlet of outdoor unit is blocked with snow, it might become difficult to get warm and it is likely to cause of the break-down. Construct a canopy or baffle board.

If children under 10 years old may approach the unit, take preventive measures so that they cannot reach the unit.

- (1) If possible, do not install the unit where it will be exposed to direct sunlight. (If necessary, install a blind that does not interfere with the air flow.)
- (2) Do not install the unit where a strong wind blows or where it is very dusty.
- (3) Do not install the unit where people pass.
- (4) Take you neighbors into consideration so that they are not disturbed by air blowing into their windows or by noise.
- (5) Provide the space shown in figure so that the air flow is not blocked. Also for efficient operation, leave open three of the four directions front, rear, and both sides.
- (6) Install the unit where keep away more than 3m from the antenna of TV set and Radio.
- (7) Outdoor unit should be set to a place where both drainage and itself will not be affected when heating.
- (8) Set up the unit in the place where has no influence on dropping the drain water from the outdoor unit.

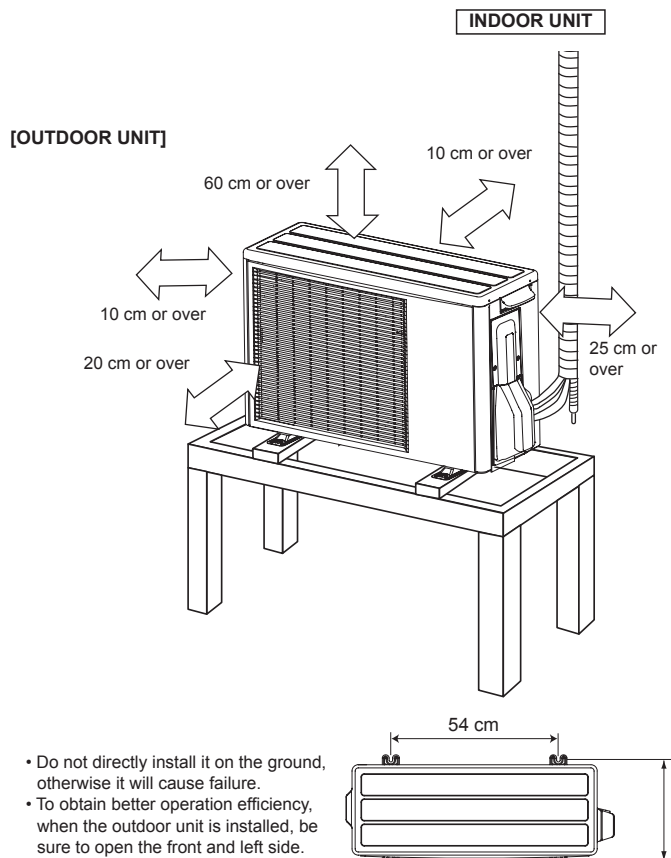

## 4. INSTALLATION

### 4.1. Outdoor unit installation

#### ⚠ WARNING

Install the unit where it will not be tilted by more than 5°.

When installing the outdoor unit where it may be exposed to strong wind, fasten it securely.

- Set the unit on a strong stand such as thing made of concrete blocks to minimize shock and vibration.
- Do not set the unit directly on the ground because it will cause trouble.

#### Connector cover removal

- Remove the tapping screws.

#### Installing the connector cover

- (1) After inserting the four hooks, then slide the cover.
- (2) Tighten the tapping screws.

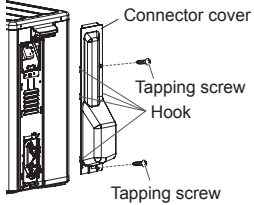

### 4.2. Outdoor unit wiring

#### ⚠ CAUTION

Match the terminal block numbers and connection cable colors with those of the indoor unit. Erroneous wiring may cause burning of the electric parts.

Connect the connection cables firmly to the terminal block. Imperfect installation may cause a fire.

Always fasten the outside covering of the connection cable with the cable clamp. (If the insulator is chafed, electric leakage may occur.)

Securely earth the power cable.

Do not use the earth screw for an external connector. Only use for interconnection between two units.

- (1) Remove the outdoor unit connector cover.
- (2) Bend the end of the cable as shown in the figure.
- (3) Connect the end of the connection cable fully into the terminal block.
- (4) Fasten the sheath with a cable clamp.
- (5) Install the connector cover.

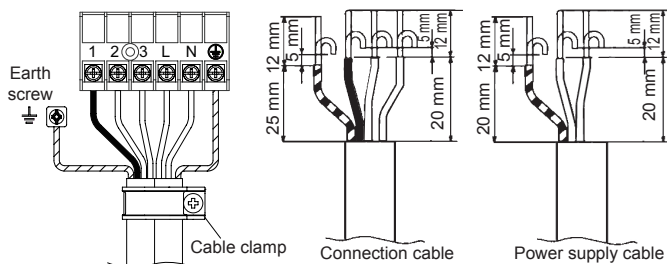
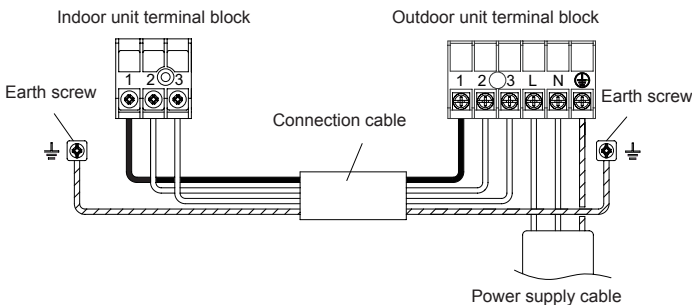
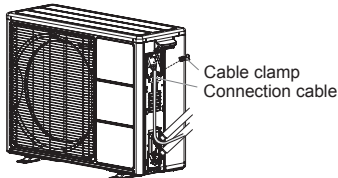

### Connection cable wiring

Run the connection cable to the rear of the outdoor unit within the A range of the arrows shown in the figure..

(The connector cover becomes difficult to install.)

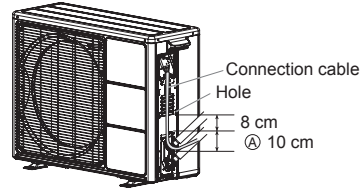

### 4.3. Connecting the piping

#### ⚠ CAUTION

Fasten a flare nut with a torque wrench as instructed in this manual. If fastened too tight, the flare nut may be broken after a long period of time and cause a leakage of refrigerant.

During installation, make sure that the refrigerant pipe is attached firmly before you run the compressor. Do not operate the compressor under the condition of refrigerant piping not attached properly with 2-way or 3-way valve open. This may cause abnormal pressure in the refrigeration cycle that leads to breakage and even injury.

#### CONNECTION

- (1) Install the outdoor unit wall cap (supplied with the optional installation set or procured at the site) to the wall pipe.
- (2) Connect the outdoor unit and indoor unit piping.
- (3) After matching the center of the flare surface and tightening the nut hand tight, tighten the nut to the specified tightening torque with a torque wrench. (Table 1)

#### FLARING

- (1) Cut the connection pipe to the necessary length with a pipe cutter.
- (2) Hold the pipe downward so that cuttings will not enter the pipe and remove the burrs.
- (3) Insert the flare nut onto the pipe and flare the pipe with a flaring tool.

Check if [L] is flared uniformly and is not cracked or scratched.

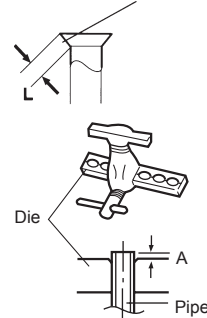

Insert the flare nut (always use the flare nut attached to the indoor and outdoor units respectively) onto the pipe and perform the flare processing with a flare tool.

Use the special R410A flare tool, or the conventional (for R22) flare tool.

When using the conventional flare tool, always use an allowance adjustment gauge and secure the A dimension shown in table 2.

#### BENDING PIPES

- (1) When bending the pipe, be careful not to crush it.
- (2) To prevent breaking of the pipe, avoid sharp bends. Bend the pipe with a radius of curvature of 70 mm or over.
- (3) If the copper pipe is bend the pipe or pulled to often, it will become stiff. Do not bend the pipes more than three times at one place.

Tighten with two wrenches.

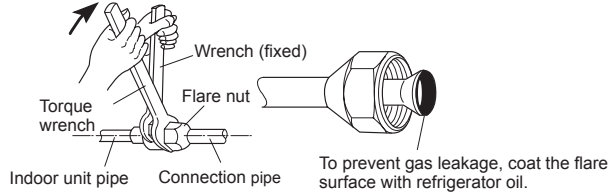

Table 1 Flare nut size and tightening torque

Flare nut	Diameter (mm) × Torque (N·m)
6.35 mm dia.	17 × 16 ~ 18
9.52 mm dia.	22 × 32 ~ 42
12.70 mm dia.	26 × 49 ~ 61

Table 2 Pipe outside diameter

Pipe outside diameter	A (mm)		
	Flare tool for R410A, clutch type	Conventional (R22) flare tool	
		Clutch type	Wing nut type
ø 6.35 mm (1/4")	0 to 0.5	1.0 to 1.5	1.5 to 2.0
ø 9.52 mm (3/8")	0 to 0.5	1.0 to 1.5	1.5 to 2.0
ø 12.70 mm (1/2")	0 to 0.5	1.0 to 1.5	1.5 to 2.0

## 4.4. Air purge

Always use a vacuum pump to purge the air.

Refrigerant for purging the air is not charged in the outdoor unit at the factory.

Close the high pressure side valve of the gauge manifold fully and do not operate it during the following work.

### CAUTION

Refrigerant must not be discharged into atmosphere.

After connecting the piping, check the joints for gas leakage with gas leak detector.

- (1) Check if the piping connections are secure.
- (2) Check that the stems of 2-way valve and 3-way valve are closed fully.
- (3) Connect the gauge manifold charge hose to the charging port of the 3-way valve (side with the projection for pushing in the valve core).
- (4) Open the low pressure side valve of the gauge manifold fully.
- (5) Operate the vacuum pump and start pump down.
- (6) Slowly loosen the flare nut of the 3-way valve and check if air enters, then retighten the flare nut.  
(When the flare nut is loosened the operating sound of the vacuum pump changes and the reading of the compound pressure gauge goes from minus to zero.)
- (7) Pump down the system for at least 15 minutes, then check if the compound pressure gauge reads -0.1 MPa (-76 cmHg, -1 bar).
- (8) At the end of pump down, close the low pressure side gauge of the gauge manifold fully and stop the vacuum pump.
- (9) Slowly loosen the valve stem of the 3-way valve. When the compound pressure gauge reading reaches 0.1-0.2 MPa, retighten the valve stem and disconnect the charge hose from the 3-way valve charging port.  
(If the stem of the 3-way valve is opened fully before the charge hose is disconnected, it may be difficult to disconnect the charge hose.)
- (10) Fully open the valve stems of the 2-way valve and 3-way valve using a hexagon wrench. (After the valve stem begins to turn, turn it with a torque of less than  $2.9 \text{ N} \cdot \text{m}$  ( $30 \text{ kgf} \cdot \text{cm}$ ) until it stops turning.)
- (11) Firmly tighten the 2-way valve and 3-way valve blank cap and the charging port cap.

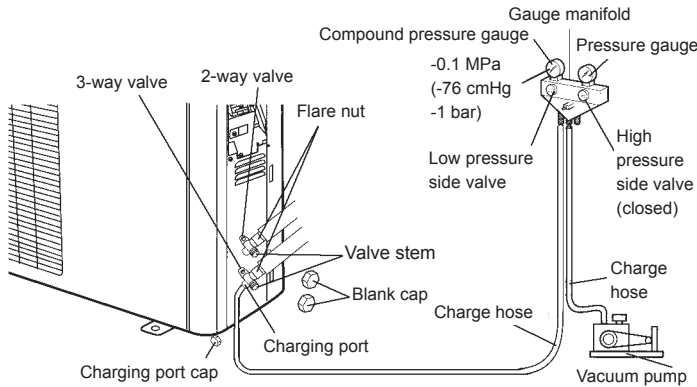

		Tightening torque
Blank cap	6.35 mm (1/4 in.)	20 to 25 N·m (200 to 250 kgf·cm)
	9.52 mm (3/8 in.)	20 to 25 N·m (200 to 250 kgf·cm)
	12.70 mm (1/2 in.)	28 to 32 N·m (280 to 320 kgf·cm)
Charging port cap		12.5 to 16.0 N·m (125 to 160 kgf·cm)

## 4.5. Test run

- Perform test operation and check items below.
- For the test operation method, refer to the operating manual.
- The outdoor unit, may not operate, depending on the room temperature. In this case, keep on pressing the MANUAL AUTO button of the indoor unit for more than 10 seconds. The operation indicator lamp and timer indicator lamp will begin to flash slowly and simultaneously during cooling test run. Then, heating test run will begin in about three minutes when HEAT is selected by the remote control operation. (Follow the operating manual for remote control operation.)
- To end test operation, keep on pressing the MANUAL AUTO button of the indoor unit for more than 3 seconds.

### OUTDOOR UNIT

- (1) Is there any abnormal noise and vibration during operation?
- (2) Will noise, wind, or drain water from the unit disturb the neighbors?
- (3) Is there any gas leakage?

## 5. PUMP DOWN

### 5.1. Pump down

### CAUTION

During the pump-down operation, make sure that the compressor is turned off before you remove the refrigerant piping.  
Do not remove the connection pipe while the compressor is in operation with 2-way or 3-way valve open. This may cause abnormal pressure in the refrigeration cycle that leads to breakage and even injury.

### PUMP DOWN OPERATION (FORCED COOLING OPERATION)

To avoid discharging refrigerant into the atmosphere at the time of relocation or disposal, recover refrigerant by doing the cooling operation or forced cooling operation according to the following procedure. (When the cooling operation cannot start in winter, and so on, start the forced cooling operation.)

- (1) Do the air purging of the charge hose by connecting the charging hose of gauge manifold to the charging port of 3-way valve and opening the low-pressure valve slightly.
- (2) Close the valve stem of 2-way valve completely.
- (3) Start the cooling operation or following forced cooling operation. Keep on pressing the MANUAL AUTO button of the indoor unit for more than 10 seconds. The operation indicator lamp and timer indicator lamp will begin to flash simultaneously during test run. (The forced cooling operation cannot start if the MANUAL AUTO button is not kept on pressing for more than 10 seconds.)
- (4) Close the valve stem of 3-way valve when the reading on the compound pressure gauge becomes 0.05~0 Mpa(0.5~0 kg/cm<sup>2</sup>).
- (5) Stop the operation.
  - Press the START/STOP button of the remote control unit to stop the operation.
  - Press the MANUAL AUTO button when stopping the operation from indoor unit side. (It is not necessary to press on keeping for more than 10 seconds.)

