

AIRSTAGE

AIR CONDITIONER

Wall-mounted type

FUJITSU

REFRIGERANT **R32**
INVERTER

SERVICE MANUAL

INDOOR



ASEH07KJCAL
ASEH09KJCAL
ASEH12KJCAL
ASEH14KJCAL

ASEH07KJCALB
ASEH09KJCALB
ASEH12KJCALB
ASEH14KJCALB

OUTDOOR



AOEH07KJCA
AOEH09KJCA
AOEH12KJCA
AOEH14KJCA

FUJITSU GENERAL LIMITED

SR_AS157ES_03
2025.08.29

Notices:

- Product specifications and design are subject to change without notice for future improvement.
- For further details, please check with our authorized dealer.

Trademarks

“AIRSTAGE Mobile” is a trademark of FUJITSU GENERAL LIMITED.

Android and Google Play are trademarks of Google LLC.

App Store is a service mark of Apple Inc., registered in the U.S. and other countries.

IOS is a trademark or registered trademark of Cisco in the U.S. and other countries and is used under license.

CONTENTS

1. GENERAL INFORMATION

2. TECHNICAL DATA AND PARTS LIST

3. TROUBLESHOOTING

4. CONTROL AND FUNCTIONS

5. FIELD WORKING

1. GENERAL INFORMATION

CONTENTS

1. GENERAL INFORMATION

1. Specifications	01-1
1-1. Indoor unit	01-1
1-2. Outdoor unit.....	01-3
2. Dimensions	01-4
2-1. Indoor unit	01-4
2-2. Outdoor unit.....	01-7

1. Specifications

1-1. Indoor unit

Type				Wall mounted				
				Inverter, Heat pump				
Model name				ASEH07KJCAL ASEH07KJCALB	ASEH09KJCAL ASEH09KJCALB	ASEH12KJCAL ASEH12KJCALB	ASEH14KJCAL ASEH14KJCALB	
Power supply intake				Outdoor unit				
System power supply		Voltage		230				
		Frequency		50				
		Available voltage range		198—264 V				
Indoor unit power supply (from outdoor unit)				230				
Capacity	Cooling	Rated	kW	2.0	2.5	3.4	4.2	
			Btu/h	6,800	8,500	11,600	14,300	
		Min.—Max.	kW	0.9—3.0	0.9—3.2	0.9—3.9	0.9—4.3	
	Heating	Rated	Btu/h	3,100—10,200	3,100—11,000	3,100—13,300	3,100—14,700	
			kW	2.5	2.8	4.0	5.2	
		Min.—Max.	kW	0.9—3.6	0.9—4.5	0.9—5.4	0.9—5.9	
Input power	Cooling	Rated	kW	0.40	0.55	0.87	1.26	
				Min.—Max.	0.25—0.76	0.25—0.86	0.25—1.22	0.25—1.43
		Heating	Rated	0.50	0.60	0.95	1.40	
	Fan	HIGH MED-HIGH MED MED-LOW LOW QUIET	W	0.25—1.04	0.25—1.41	0.25—1.64	0.25—1.80	
				18.0	21.0	26.0	34.0	
				15.0	16.0	20.0	24.0	
				13.0		16.0	17.0	
				11.0			12.0	
				9.0			10.0	
	Current	Cooling Heating	Rated	A	2.4	3.0	4.0	5.8
					2.9	3.4	4.6	6.6
	Energy efficiency class	Cooling			A+++			
Heating (Average)			A+++					
Pdesign	Cooling		kW	2.0	2.5	3.4	4.2	
	Heating (Average)			2.3	2.4	2.5	4.0	
SEER	Cooling		kWh/kWh	9.6	9.2	8.7	7.9	
SCOP	Heating (Average)			5.1			4.6	
Annual energy consumption	QCE		kWh/a	73	95	137	186	
	QHE (Average)			631	658	685	1,216	
EER	Cooling		kW/kW	5.00	4.55	3.91	3.33	
COP	Heating			5.00	4.67	4.21	3.71	
Sensible capacity	Cooling		kW	1.92	2.22	2.70	3.20	
Power factor	Cooling			%	72.0	80.0	95.0	94.0
Moisture removal	Heating		L/h (pints/h)	75.0		77.0	92.0	
				1.0 (1.8)	1.5 (2.6)	1.6 (2.8)		
Maximum operating current*1	Cooling		A	1.0 (1.8)				
	Heating			6.5			7.0	
Fan	Airflow rate	Cooling	m ³ /h	9.0				
				HIGH	540	580	630	720
				MED-HIGH	480	500	550	600
				MED	430		470	490
				MED-LOW	380		400	
				LOW	330		320	
		Heating	QUIET	260		250		
			HIGH	580		630	720	
			MED-HIGH	500		550	600	
			MED	430		470	490	
			MED-LOW	380		400		
			LOW	330		320		
			QUIET	270		250		
			Type × Qty	W		Crossflow fan × 1		
Motor output			27					
Sound pressure level*2	Cooling	dB (A)	HIGH	36	38	41	45	
			MED-HIGH	34		38	40	
			MED	31		34	35	
			MED-LOW	28		30		
			LOW	24		25		
			QUIET	19		20		
	Heating	HIGH	38		41	44		
		MED-HIGH	34		38	39		
		MED	31		34	35		
		MED-LOW	28		30			
		LOW	24		25			
		QUIET	20		21			
		Sound power level	Cooling	dB (A)	51	52	56	59
			Heating		52		56	59

Type			Wall mounted			
			Inverter, Heat pump			
Model name			ASEH07KJCAL ASEH07KJCALB	ASEH09KJCAL ASEH09KJCALB	ASEH12KJCAL ASEH12KJCALB	ASEH14KJCAL ASEH14KJCALB
Heat exchanger	Dimensions (H × W × D)	mm	Main 1: 210 × 618 × 26.6 Main 2: 112 × 618 × 20		Main 1: 210 × 618 × 26.6 Main 2: 112 × 618 × 20 Sub 1: 84 × 618 × 13.3 Sub 2: 84 × 618 × 13.3	
	Fin pitch		Main 1: 1.2 Main 2: 1.1		Main 1: 1.2 Main 2: 1.1 Sub 1: 1.4 Sub 2: 1.4	
	Rows × Stages	Main 1: 2 × 10 Main 2: 2 × 7		Main 1: 2 × 10 Main 2: 2 × 7 Sub 1: 1 × 4 Sub 2: 1 × 4		
	Pipe type	Copper tube				
	Fin type	Aluminum				
Enclosure	Material	Polystyrene				
	Color	KJCAL: White Approximate color of Munsell 9PB 9.1/0.2 KJCALB: Soft black Approximate color of Munsell N3/				
Dimensions (H × W × D)	Net	mm	270 × 798 × 240			
	Gross		308 × 849 × 345			
Weight	Net	kg	10.0		10.5	
	Gross		14.0		15.0	
Connection pipe	Size	mm (in)	Ø6.35 (Ø1/4)			
	Method		Ø9.52 (Ø3/8) Flare			
Drain hose	Material	Polypropylene + High-density polyethylene				
	Tip diameter	mm	Ø13.8 (I.D.), Ø15.0 to Ø16.8 (O.D.)			
Operation range	Cooling	°C	18 to 32			
	Heating	%RH	80 or less			
Remote controller type			Wireless (Option: Wired, Mobile app ^{*3} [AIRSTAGE Mobile])			
NOTES: <ul style="list-style-type: none"> Specifications are based on the following conditions: <ul style="list-style-type: none"> Cooling: Indoor temperature of 27°CDB/19°CWB, and outdoor temperature of 35°CDB/24°CWB. Heating: Indoor temperature of 20°CDB/—°CWB, and outdoor temperature of 7°CDB/6°CWB. Pipe length: 5.0 m, Height difference: 0 m. (Between outdoor unit and indoor unit.) Protective function might work when using it outside the operation range. *1: Maximum operating current is the total current of the indoor unit and the outdoor unit. *2: Sound pressure level: <ul style="list-style-type: none"> Measured values in manufacturer's anechoic chamber. Because of the surrounding sound environment, the sound levels measured in actual installation conditions might be higher than the specified values here. *3: Available on Google Play™ store or on App Store®. This data is based on EN 14511 standard. 						

1-2. Outdoor unit

Type			Inverter, Heat pump				
Model name			AOEH07KJCA	AOEH09KJCA	AOEH12KJCA	AOEH14KJCA	
Power supply			230 V~ 50 Hz				
Power supply intake			Outdoor unit				
Available voltage range			198—264 V				
Starting current			A	2.9	3.4	4.6	6.6
Fan	Airflow rate	Cooling	m ³ /h	1,390	1,480	1,690	
		Heating		1,350	1,420	1,690	1,860
	Type × Qty	Propeller fan × 1					
Motor output			W	23			
Sound pressure level *		Cooling	dB (A)	42	44	47	
		Heating		42	44	47	52
Sound power level		Cooling	dB (A)	55	56	58	59
		Heating		54	55	59	63
Heat exchanger type	Dimensions (H × W × D)		mm	Main 1: 504 × 888 × 18.19		Main 1: 504 × 881 × 18.19	
	Fin pitch			Main 1: 1.3 Main 2: 1.3			
	Rows × Stages		Main 1: 1 × 24 Main 2: 1 × 24				
	Pipe type		Copper tube				
	Fin type	Type (Material)	Aluminum				
	Surface treatment	Blue fin					
Compressor	Type	DC rotary					
	Motor output	W	600				
Refrigerant	Type (Global warming potential)		R32 (675)				
	Charge	g	720	870			
Refrigerant oil	Type	RB74AF					
	Amount	cm ³	280				
Enclosure	Material		Steel sheet				
	Color		Beige Approximate color of Munsell 10YR 7.5/1.0				
Dimensions (H × W × D)	Net		mm	542 × 799 × 290			
	Gross			602 × 940 × 375			
Weight	Net		kg	30	31		
	Gross			35	36		
Connection pipe	Size	Liquid	mm (in)	Ø6.35 (Ø1/4)			
		Gas		Ø9.52 (Ø3/8)			
	Method		Flare				
	Pre-charge length		m	15			
	Min. length			3			
	Max. length			20			
Max. height difference		15					
Operation range		Cooling	°C	-10 to 50			
		Heating		-20 to 24			
Drain hose	Material		Polypropylene				
	Tip diameter		mm	Ø13.0 (I.D.), Ø16.0 to Ø16.8 (O.D.)			
NOTES:							
<ul style="list-style-type: none"> • Specifications are based on the following conditions: <ul style="list-style-type: none"> – Cooling: Indoor temperature of 27°CDB/19°CWB, and outdoor temperature of 35°CDB/24°CWB. – Heating: Indoor temperature of 20°CDB/—°CWB, and outdoor temperature of 7°CDB/6°CWB. – Pipe length: 5 m, Height difference: 0 m. • Protective function might work when using it outside the operation range. • *: Sound pressure level <ul style="list-style-type: none"> – Measured values in manufacturer's semi-anechoic chamber. – Because of the surrounding sound environment, the sound levels measured in actual installation conditions might be higher than the specified values here. • This data is based on EN 14511 standard. 							

2. Dimensions

2-1. Indoor unit

- Models: ASEH07KJCAL, ASEH09KJCAL, ASEH12KJCAL, ASEH14KJCAL, ASEH07KJCALB, ASEH09KJCALB, ASEH12KJCALB, and ASEH14KJCALB

Unit: mm

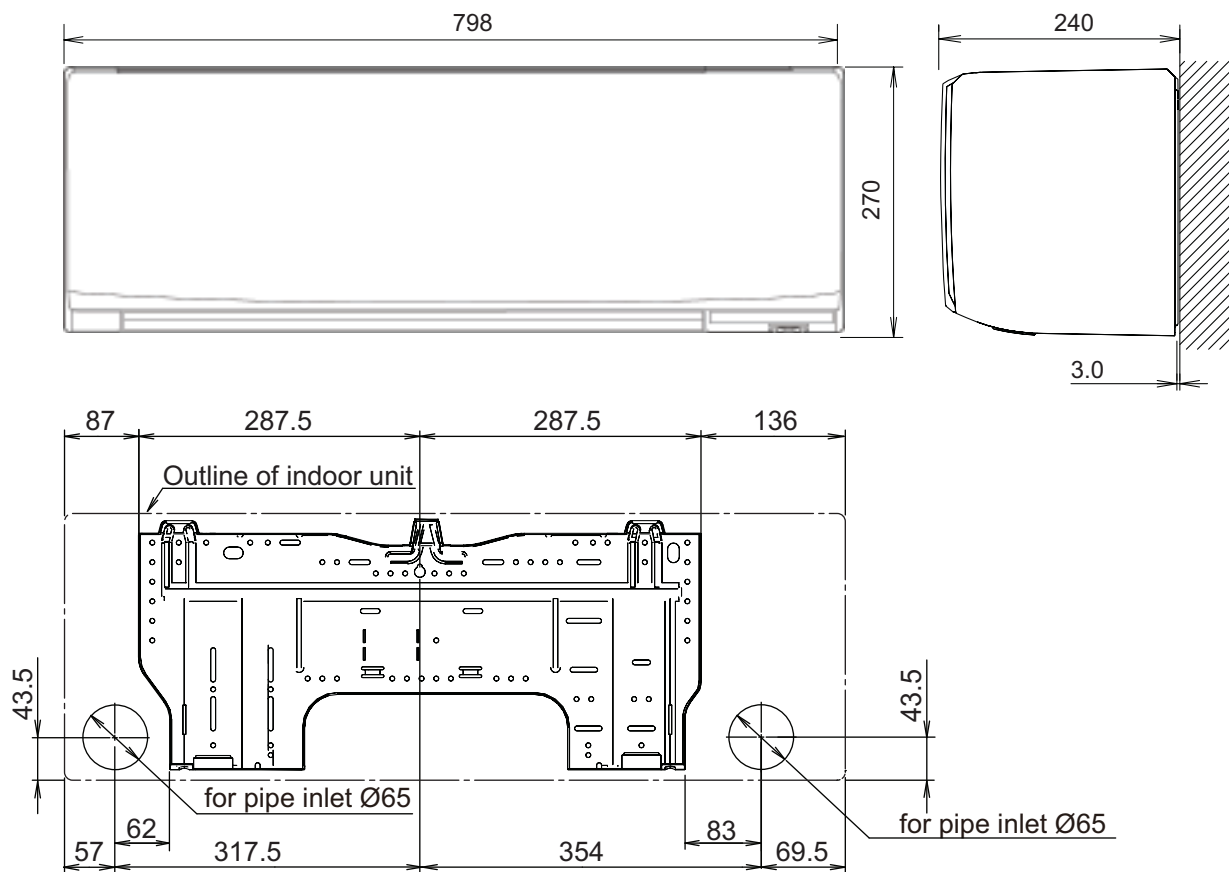

● Installation space requirement

Provide sufficient installation space for product safety.

Unit: mm

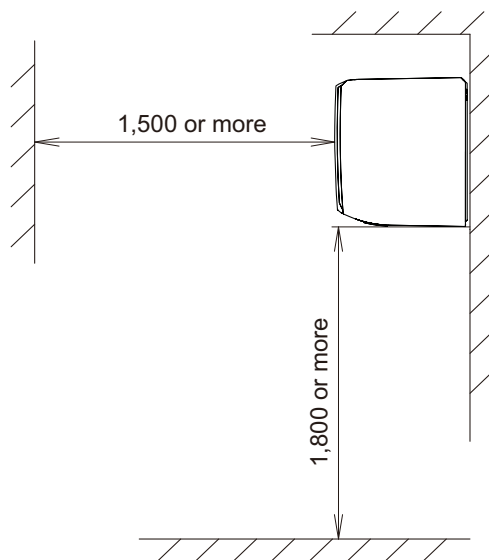
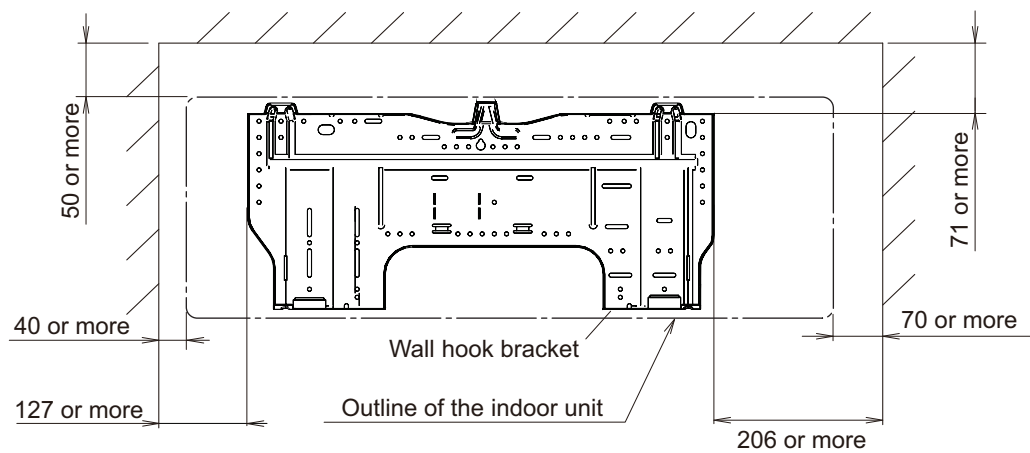

■ Pipe exit length from the rear

Design the system considering the length of the pipes or hose exiting from the rear of the indoor unit.

NOTE: Detailed shapes of the indoor unit and the tip of each pipe or hose may vary depending on the model.

Unit: mm

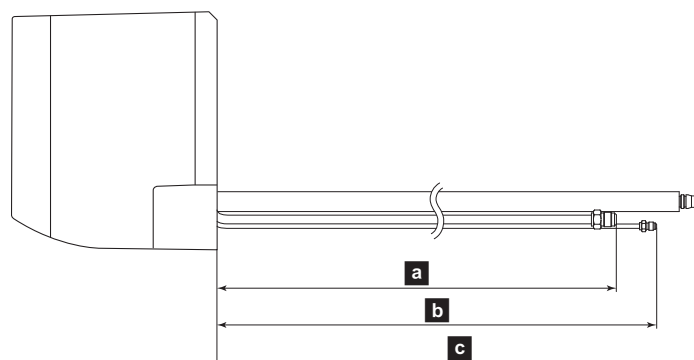

Model name	Approximate length		
	a Gas pipe	b Liquid pipe	c Drain hose
ASEH07KJCAL ASEH07KJCALB ASEH09KJCAL ASEH09KJCALB ASEH12KJCAL ASEH12KJCALB ASEH14KJCAL ASEH14KJCALB	380	430	470

2-2. Outdoor unit

■ Models: AOEH07KJCA, AOEH09KJCA, AOEH12KJCA, and AOEH14KJCA

Unit: mm

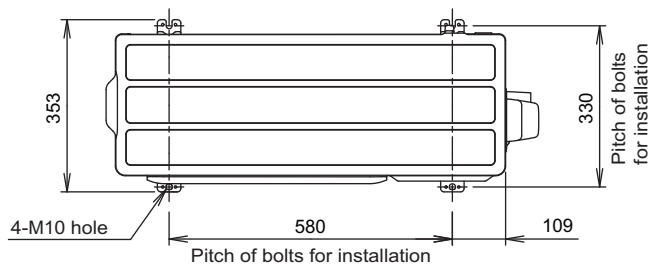

Top view

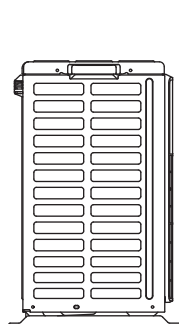

Side view

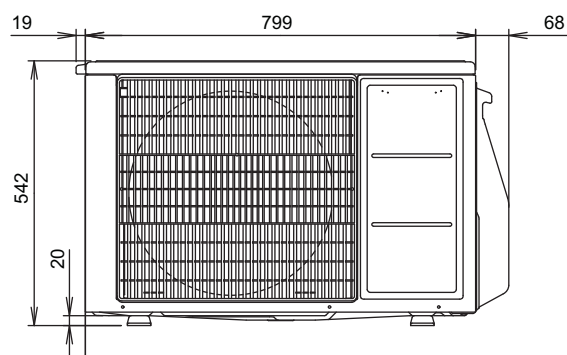

Front view

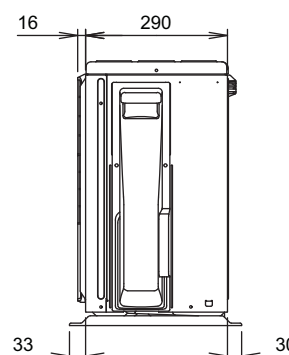

Side view

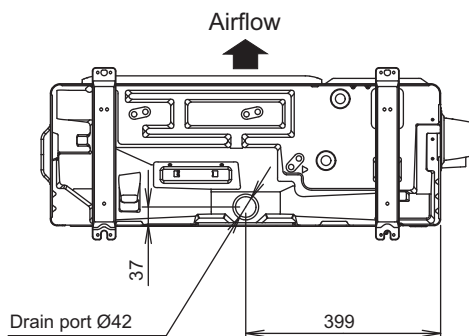

Bottom view

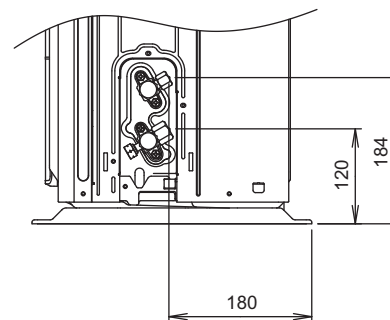

Side view (Valve part)

2. TECHNICAL DATA AND PARTS LIST

CONTENTS

2. TECHNICAL DATA AND PARTS LIST

1. Precautions	02-1
2. Indoor unit parts list	02-2
2-1. Models: ASEH07KJCAL, ASEH09KJCAL, ASEH12KJCAL, ASEH14KJCAL, ASEH07KJCALB, ASEH09KJCALB, ASEH12KJCALB, and ASEH14KJCALB	02-2
3. Outdoor unit parts list	02-6
3-1. Models: AOEH07KJCA, AOEH09KJCA, AOEH12KJCA, and AOEH14KJCA	02-6
4. Accessories	02-10
4-1. Indoor unit	02-10
4-2. Outdoor unit.....	02-10
5. Optional parts	02-11
5-1. Indoor unit	02-11
6. Refrigerant system diagrams	02-13
6-1. Models: AOEH07KJCA, AOEH09KJCA, AOEH12KJCA, and AOEH14KJCA	02-13
7. Wiring diagrams	02-14
7-1. Indoor unit	02-14
7-2. Outdoor unit.....	02-15
8. PC board diagrams	02-16
8-1. Models: ASEH07KJCAL, ASEH09KJCAL, ASEH12KJCAL, ASEH14KJCAL, ASEH07KJCALB, ASEH09KJCALB, ASEH12KJCALB, and ASEH14KJCALB	02-16
8-2. Models: AOEH07KJCA, AOEH09KJCA, AOEH12KJCA, and AOEH14KJCA	02-17

1. Precautions

When you start servicing, pay attention to the following points. For detailed precautions, refer to the installation manual of the products.

⚠ CAUTION

- Service personnel
 - Any person who is involved with working on or breaking into a refrigerant circuit should hold a current valid certificate from an industry-accredited assessment authority, which authorizes their competence to handle refrigerants safely in accordance with an industry recognized assessment specification.
 - Servicing shall only be performed as recommended by the equipment manufacturer. Maintenance and repair requiring the assistance of other skilled personnel shall be carried out under the supervision of the person competent in the use of flammable refrigerants.
 - Servicing shall be performed only as recommended by the manufacturer.
 - Work
 - Prior to beginning work on systems containing flammable refrigerants, safety checks are necessary to ensure that the risk of ignition is minimized. When repairing the refrigerant system, refer to the precautions written in the installation manual of the products before you start servicing.
 - Work shall be undertaken under a controlled procedure so as to minimize the risk of a flammable gas or vapor being present while the work is being performed.
 - All maintenance staff and others working in the local area shall be instructed on the nature of work being carried out.
 - Work in confined spaces shall be avoided.
 - The area around the workspace shall be sectioned off.
 - Ensure that the conditions within the area have been made safe by control of flammable material.
 - Electric shock may occur. After turning off the power, always wait 5 minutes before touching electrical components.
 - Do not touch the fins of the heat exchanger. Touching the heat exchanger fins could result in damage to the fins or personal injury such as skin rupture.
 - Do not place any other electrical products or household belongings under the product.
 - Condensation dripping from the product might get them wet, and may cause damage or malfunction to the property.
 - Checking for presence of refrigerant
 - The area shall be checked with an appropriate refrigerant leak detector prior to and during work, to ensure the technician is aware of potentially flammable atmospheres.
 - Ensure that the leak detector being used is suitable for use with flammable refrigerants, i.e. non-sparking, adequately sealed or intrinsically safe.
-
- Service parts information and design are subject to change without notice for product improvement.
 - For the latest information of the service parts, refer to our Service Portal.
<https://fujitsu-general.force.com/portal/>
 - Precise figure of the service parts listed in this manual may differ from the actual service parts.

2. Indoor unit parts list

2-1. Models: ASEH07KJCAL, ASEH09KJCAL, ASEH12KJCAL, ASEH14KJCAL, ASEH07KJCALB, ASEH09KJCALB, ASEH12KJCALB, and ASEH14KJCALB

■ Exterior parts

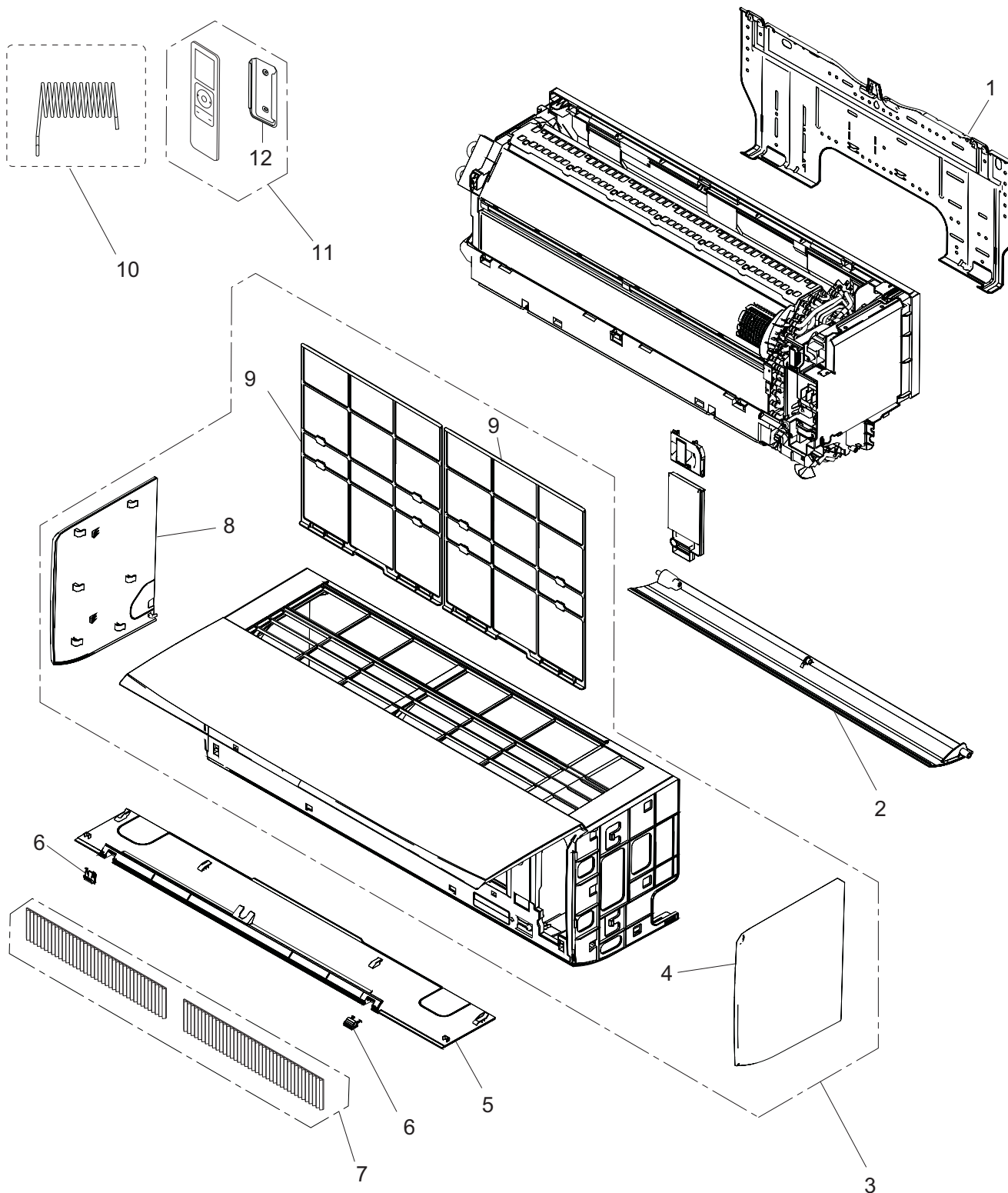

Item no.	Part no.	Part name
1	9363902006	Bracket panel
2	9301299007	Horizontal louver assy (for KJCAL)
	9301299014	Horizontal louver assy (for KJCALB)
3	9333886343	Front panel total assy (for KJCAL)
	9333886404	Front panel total assy (for KJCALB)
4	9363615005	Decoration panel R (for KJCAL)
	9363615012	Decoration panel R (for KJCALB)
5	9319863030	Under cover assy (for KJCAL)
	9319863047	Under cover assy (for KJCALB)
6	9363826005	Screw cover (for KJCAL)
	9363826012	Screw cover (for KJCALB)
7	9317250009	Air clean filter assy
8	9363614008	Decoration panel L (for KJCAL)
	9363614015	Decoration panel L (for KJCALB)
9	9363877007	Air filter
10	9333951003	Louver spring
11	9364008011	Remote controller total assy (for KJCAL)
	9364008042	Remote controller total assy (for KJCALB)
12	9364012001	Remote controller holder (for KJCAL)
	9364012018	Remote controller holder (for KJCALB)

■ Base, evaporator, and control unit

TECHNICAL DATA
AND PARTS LIST

TECHNICAL DATA
AND PARTS LIST

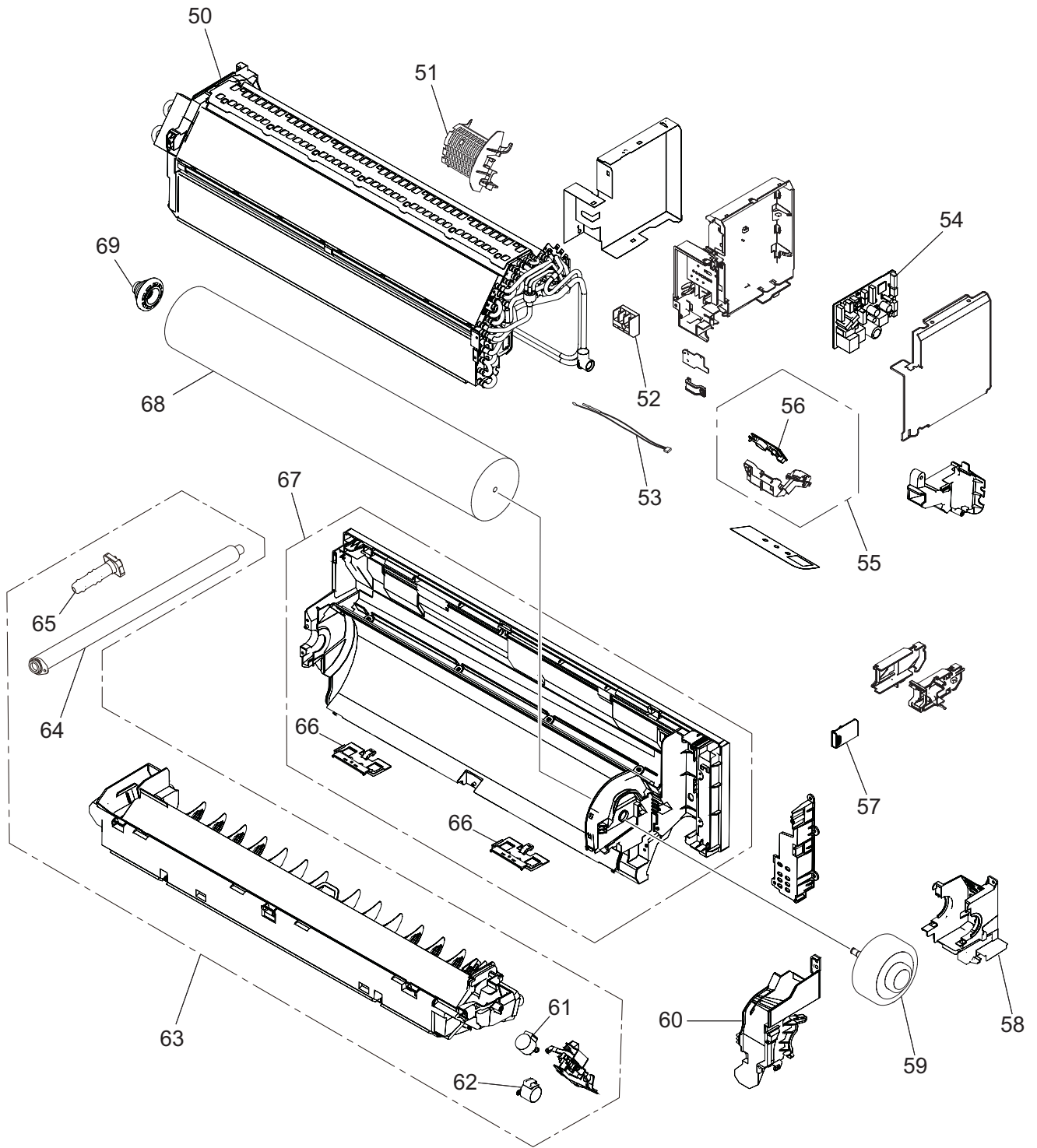

Item no.	Part no.	Part name
50	9362077095	Evaporator total assy (for 07—09 models)
	9362077101	Evaporator total assy (for 12—14 models)
51	9387467017	Room thermistor holder
52	9901013010	Terminal block 3P
53	9901160042	Thermistor assy
54	9712546912	Main PCB (for 07 model)
	9712546929	Main PCB (for 09 model)
	9712546936	Main PCB (for 12 model)
	9712546943	Main PCB (for 14 model)
55	9711146120	Display assy (for KJCAL)
	9711146342	Display assy (for KJCALB)
56	9711147028	Indicator PCB
57	9300506007	WLAN Adapter
58	9387447002	Motor case
59	9603688028	DC fan motor (for 07—09 models)
	9603492021	DC fan motor (for 12—14 model)
60	9387713022	Motor cover assy
61	9901011023	Stepping motor (for Vertical louver control)
62	9901011030	Stepping motor (for Horizontal louver control)
63	9333911076	Drain pan total assy
64	9316904002	Drain hose assy
65	9316177017	Drain cap
66	9363328004	Pipe bracket A
67	9333882109	Base assy
68	9333606040	Crossflow fan assy
69	9333628004	Bearing D assy
—	9901010071	Wire with connector (CN75 on Main PCB—WLAN Adapter)
—	9701439225	Wire with terminal (E1 on Main PCB—Earth)

3. Outdoor unit parts list

3-1. Models: AOEH07KJCA, AOEH09KJCA, AOEH12KJCA, and AOEH14KJCA

■ Exterior parts and Chassis

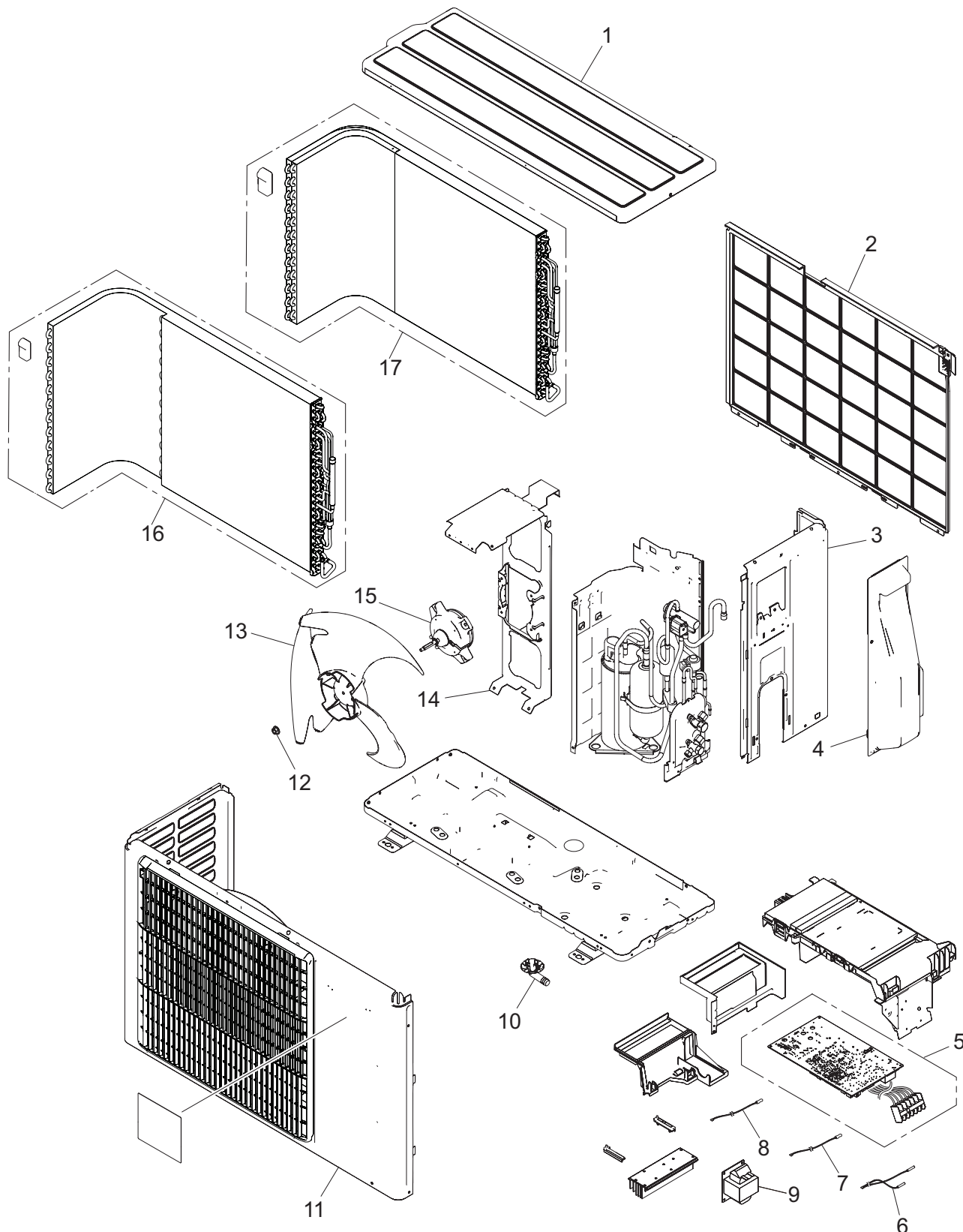

TECHNICAL DATA
AND PARTS LIST

TECHNICAL DATA
AND PARTS LIST

Item no.	Part no.	Part name
1	9322556028	Top panel assy
2	9322811011	Protective net assy
3	9322552020	Cabinet right assy
4	9322570147	Switch cover assy
5	9712996809	Main PCB (for 07 model)
	9712996816	Main PCB (for 09 model)
	9712996823	Main PCB (for 12 model)
	9712996830	Main PCB (for 14 model)
6	9900727062	Thermistor assy
7	9900850012	Thermistor (Outdoor temp.)
8	9900984014	Thermistor (Heat exchanger temp.)
9	9901012013	Reactor
10	9322144003	Drain pipe
11	9322555410	Front panel assy
12	0700103070	Nut
13	9322136008	Propeller fan
14	9322553010	Motor bracket assy
15	9603553005	DC fan motor
16	9362146234	Heat exchanger unit (for 07—09 models)
17	9362146241	Heat exchanger unit (for 12—14 models)

■ Compressor

TECHNICAL DATA
AND PARTS LIST

TECHNICAL DATA
AND PARTS LIST

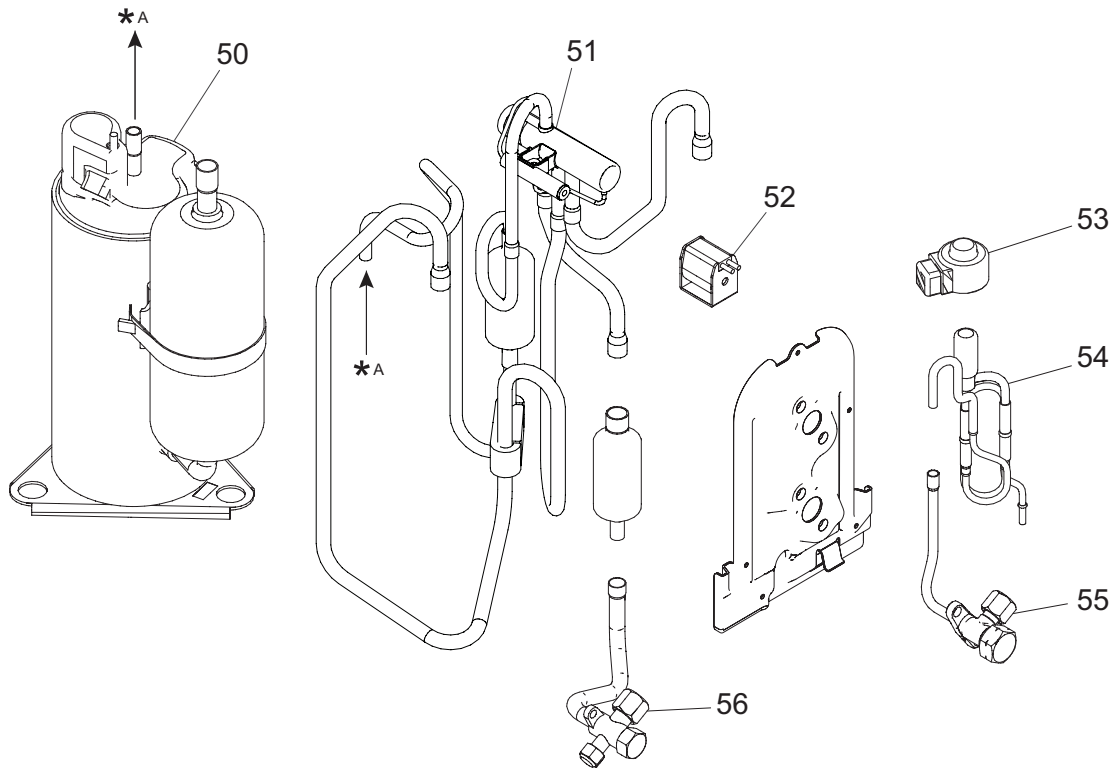









Item no.	Part no.	Part name
50	9324643023	Compressor assy
51	9324658003	4-way valve assy
52	9970195006	Solenoid
53	9970222016	Expansion valve coil
54	9322463050	Pulse motor valve assy
55	9322494009	2-way valve assy
56	9322499004	3-way valve assy

4. Accessories

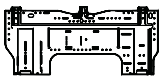
4-1. Indoor unit

- **Models: ASEH07KJCAL, ASEH09KJCAL, ASEH12KJCAL, ASEH14KJCAL, ASEH07KJCALB, ASEH09KJCALB, ASEH12KJCALB, and ASEH14KJCALB**

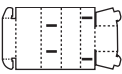
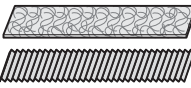
Part name	Exterior	Qty	Part name	Exterior	Qty
Operation manual		1	Self-tapping screw (Large)		5
Installation manual		1	Self-tapping screw (Small)		2
Remote controller		1	Wall hook bracket		1
Battery		2	Filter holder		2
Remote controller holder		1	Cloth tape		1
Installation spacer		1	Air cleaning filters		1

4-2. Outdoor unit



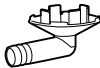

- **Models: AOEH07KJCA, AOEH09KJCA, AOEH12KJCA, and AOEH14KJCA**

Part name	Exterior	Qty	Part name	Exterior	Qty
Installation manual		1	Drain pipe		1

5. Optional parts

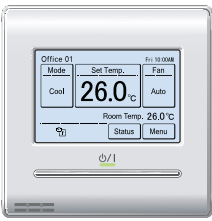
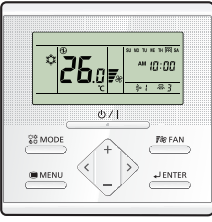
5-1. Indoor unit







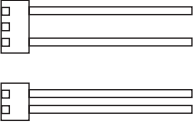
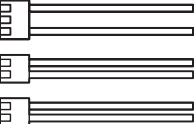

■ Controllers

Exterior	Part name	Model name	Summary
	Wired Remote Controller (Touch Panel)	UTY-RVRY	Remote controller that provides the functions you need in a sleek design that uniquely transforms itself to blend with any interior. Optional Communication Kit is necessary for installation.
	Wired Remote Controller (Touch Panel)	UTY-RNRYZ*	Easy finger touch operation with LCD panel. Backlit LCD enables easy operation in a dark room. Optional Communication Kit is necessary for installation.
	Wired Remote Controller	UTY-RLRY	High visibility and easy operation. Room temperature can be accurately controlled using the thermo sensor. Optional Communication Kit is necessary for installation.
	Compact Wired Remote Controller	UTY-RCRYZ1	Compact body and easy operation. Room temperature can be accurately controlled using the thermo sensor. Optional Communication Kit is necessary for installation.
	Simple Remote Controller	UTY-RSRY	Compact remote controller concentrates on the basic functions such as Start/ Stop, fan control, temperature setting, and operation mode. Optional Communication Kit is necessary for installation.
	Simple Remote Controller	UTY-RHRY	Compact remote controller concentrates on the basic functions such as Start/ Stop, fan control, and temperature setting. Optional Communication Kit is necessary for installation.

NOTES:

- Available functions may differ by the remote controller. For details, refer to the operation manual.
- When using the group controlling system of the Wired Remote Controller, using WLAN Adapter is prohibited.

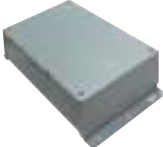
■ Others

Exterior	Part name	Model name	Summary
	Air Cleaning Filter	UTR-FA16-5	Air Cleaning Filter can be mounted to the indoor unit. (For antibacterial)
	External Connect Kit	UTY-XWZX	Use to connect with various peripheral devices and air conditioner PCB. Connecting point: CN46 and CN47 on Main PCB
	External Connect Kit	UTY-XWZXZ5	Required when external device is connected. Connecting point: CN46 and CN47 on Main PCB
	External Input and Output PCB	UTY-XCSXZ2	Use to connect with external devices and air conditioner PCB. Optional External Connect Kit might be required to connect locally purchased devices via this PCB. Connecting point: CN65 on Main PCB
	Communication Kit	UTY-TWRXZ2	Use to connect Non-polar 2-core wired remote controller. Connecting point: CN13 on Main PCB
	Modbus Converter	UTY-VMSX	For connection between indoor unit with UART interface and a Modbus open network. Connecting point: CN65 on Main PCB
	KNX Converter	UTY-VKSX	For connection between indoor unit with UART interface and a KNX open network. Connecting point: CN65 on Main PCB
	Network Converter	UTY-VTGX	This converter is required when connecting single split system to VRF network system. Optional Communication Kit is necessary for installation.
	Network Converter (AC power supply)	UTY-VTGXV	This converter is required when connecting single split system to VRF network system. Optional Communication Kit is necessary for installation.
	External Switch Controller	UTY-TERX	Air conditioner switching can be controlled by connecting other external sensor switches. Optional Communication Kit is necessary for installation.

6. Refrigerant system diagrams

6-1. Models: AOEH07KJCA, AOEH09KJCA, AOEH12KJCA, and AOEH14KJCA

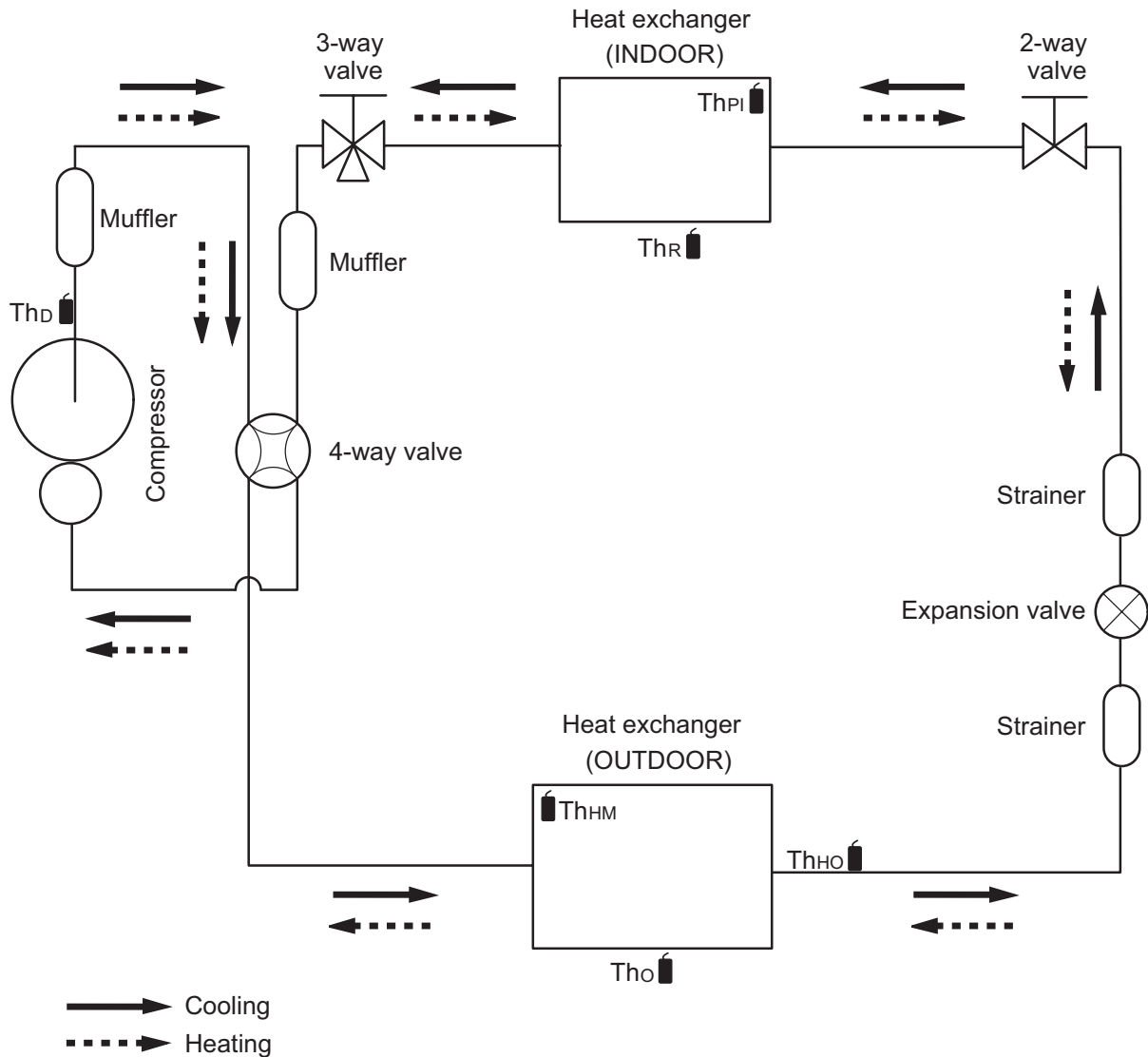

Th_D : Thermistor (Discharge temperature)

Th_{HM} : Thermistor (Heat exchanger middle temperature)

Th_O : Thermistor (Outdoor temperature)

Th_{HO} : Thermistor (Heat exchanger out temperature)

Th_{PI} : Thermistor (Pipe temperature)

Th_R : Thermistor (Room temperature)

7. Wiring diagrams

7-1. Indoor unit

■ Models: ASEH07KJCAL, ASEH09KJCAL, ASEH12KJCAL, ASEH14KJCAL, ASEH07KJCALB, ASEH09KJCALB, ASEH12KJCALB, and ASEH14KJCALB

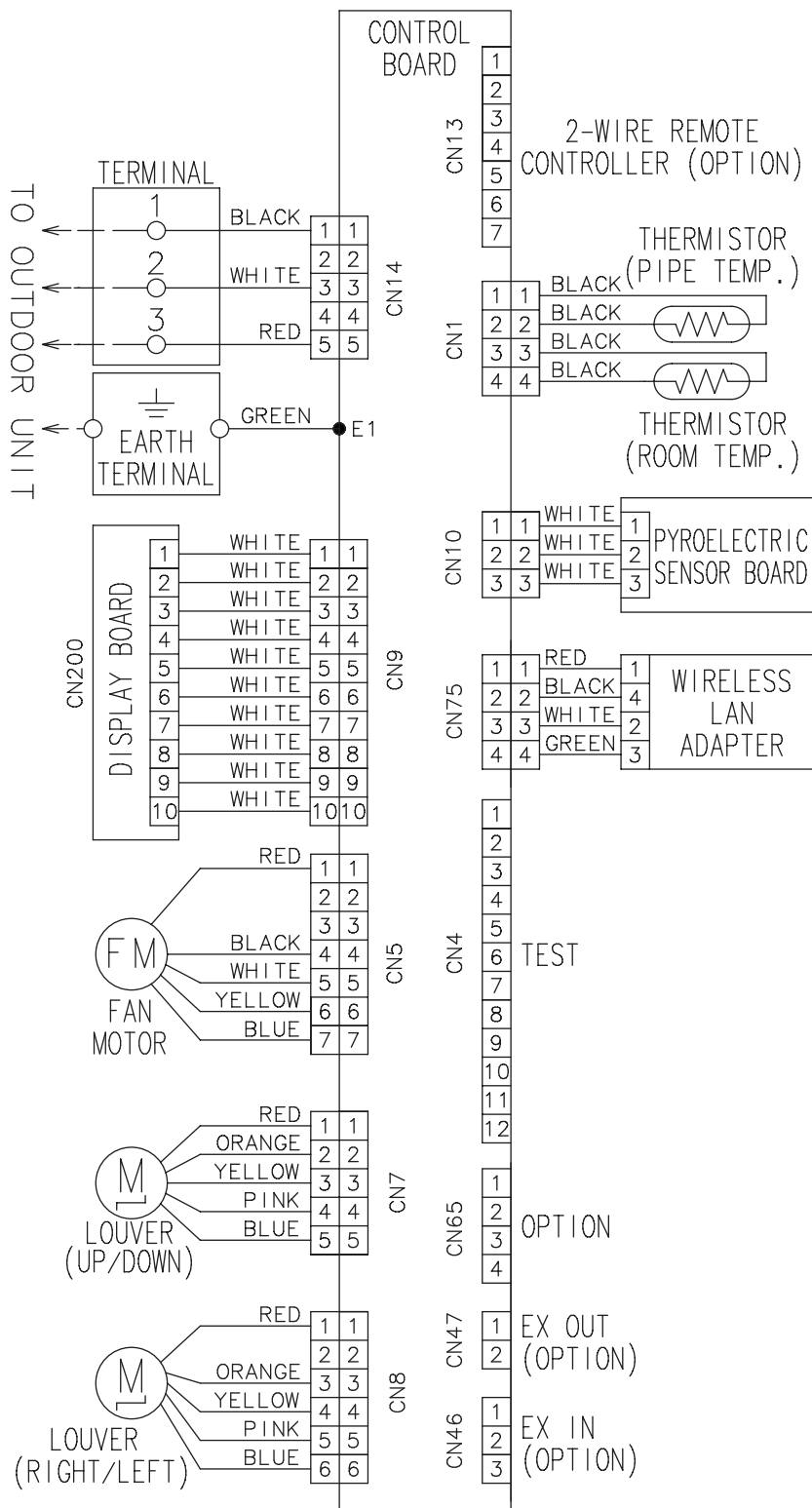

TECHNICAL DATA AND PARTS LIST

TECHNICAL DATA AND PARTS LIST

7-2. Outdoor unit

Models: AOEH07KJCA, AOEH09KJCA, AOEH12KJCA, and AOEH14KJCA

TECHNICAL DATA AND PARTS LIST

TECHNICAL DATA AND PARTS LIST

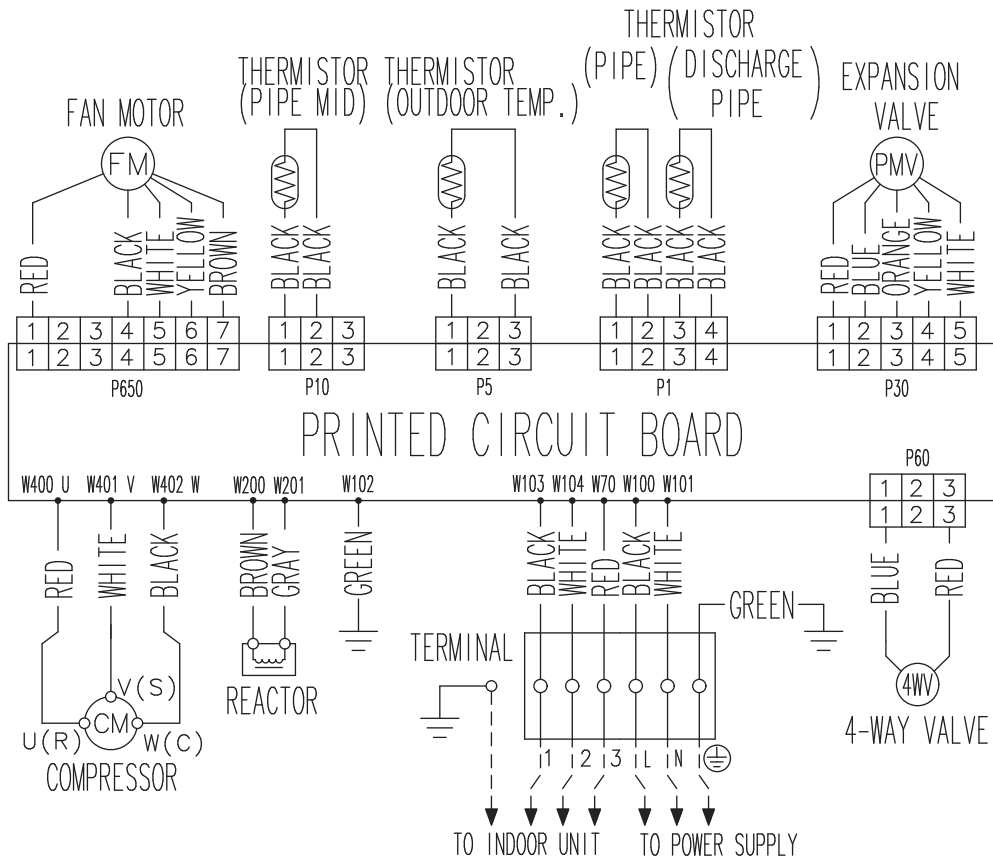

8. PC board diagrams

8-1. Models: ASEH07KJCAL, ASEH09KJCAL, ASEH12KJCAL, ASEH14KJCAL, ASEH07KJCALB, ASEH09KJCALB, ASEH12KJCALB, and ASEH14KJCALB

TECHNICAL DATA AND PARTS LIST

TECHNICAL DATA AND PARTS LIST

CONTROL UNIT

05 model: EZ-02447HSE, 05(B) model: EZ-025KHSE
 07 model: EZ-02448HSE, 07(B) model: EZ-025LHSE
 09 model: EZ-02449HSE, 09(B) model: EZ-025MHSE
 12 model: EZ-0244AHSE, 12(B) model: EZ-025PHSE
 14 model: EZ-0244BHSE, 14(B) model: EZ-025RHSE

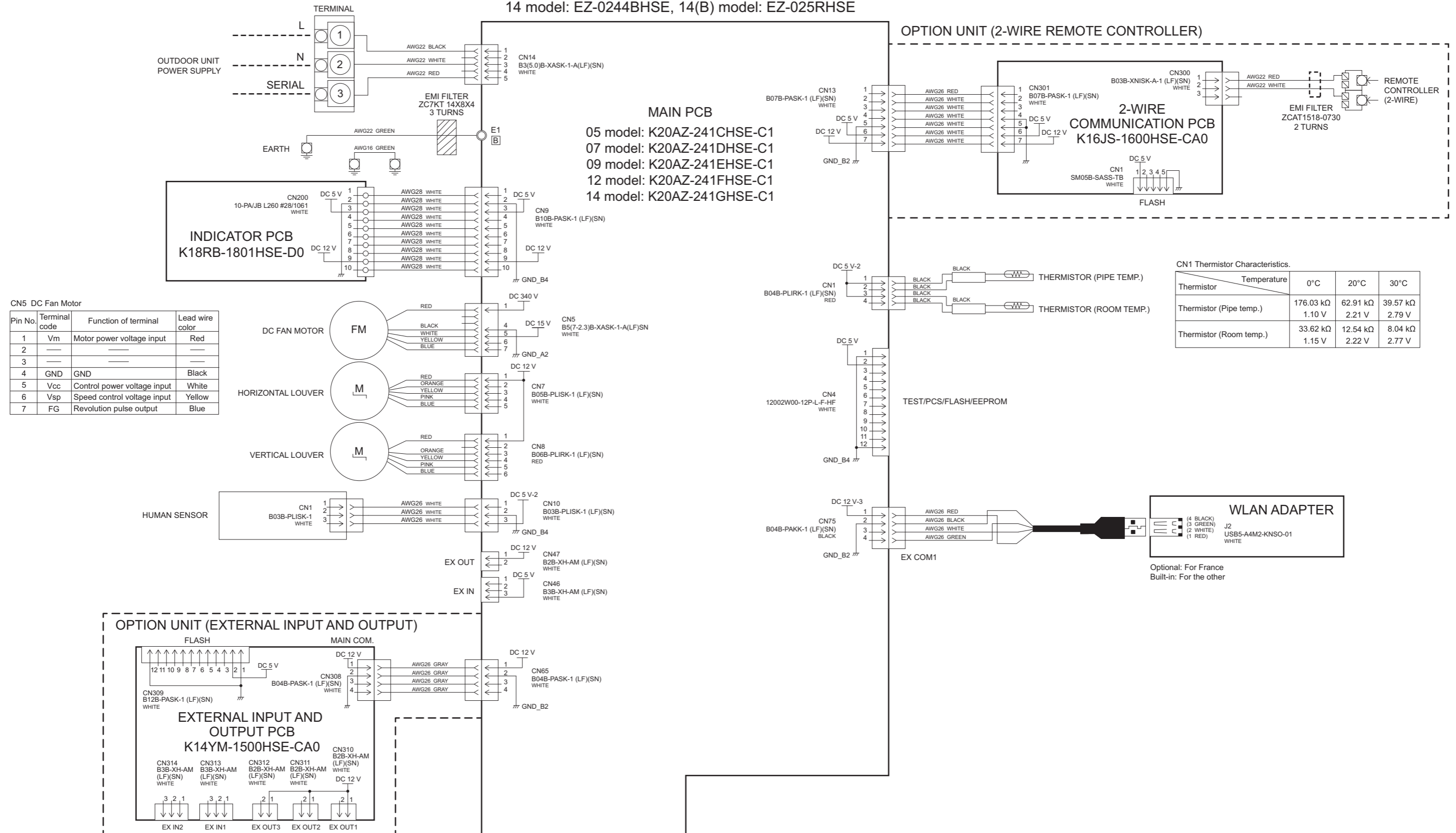

8-2. Models: AOEH07KJCA, AOEH09KJCA, AOEH12KJCA, and AOEH14KJCA

CONTROL UNIT EZ-0240THUE

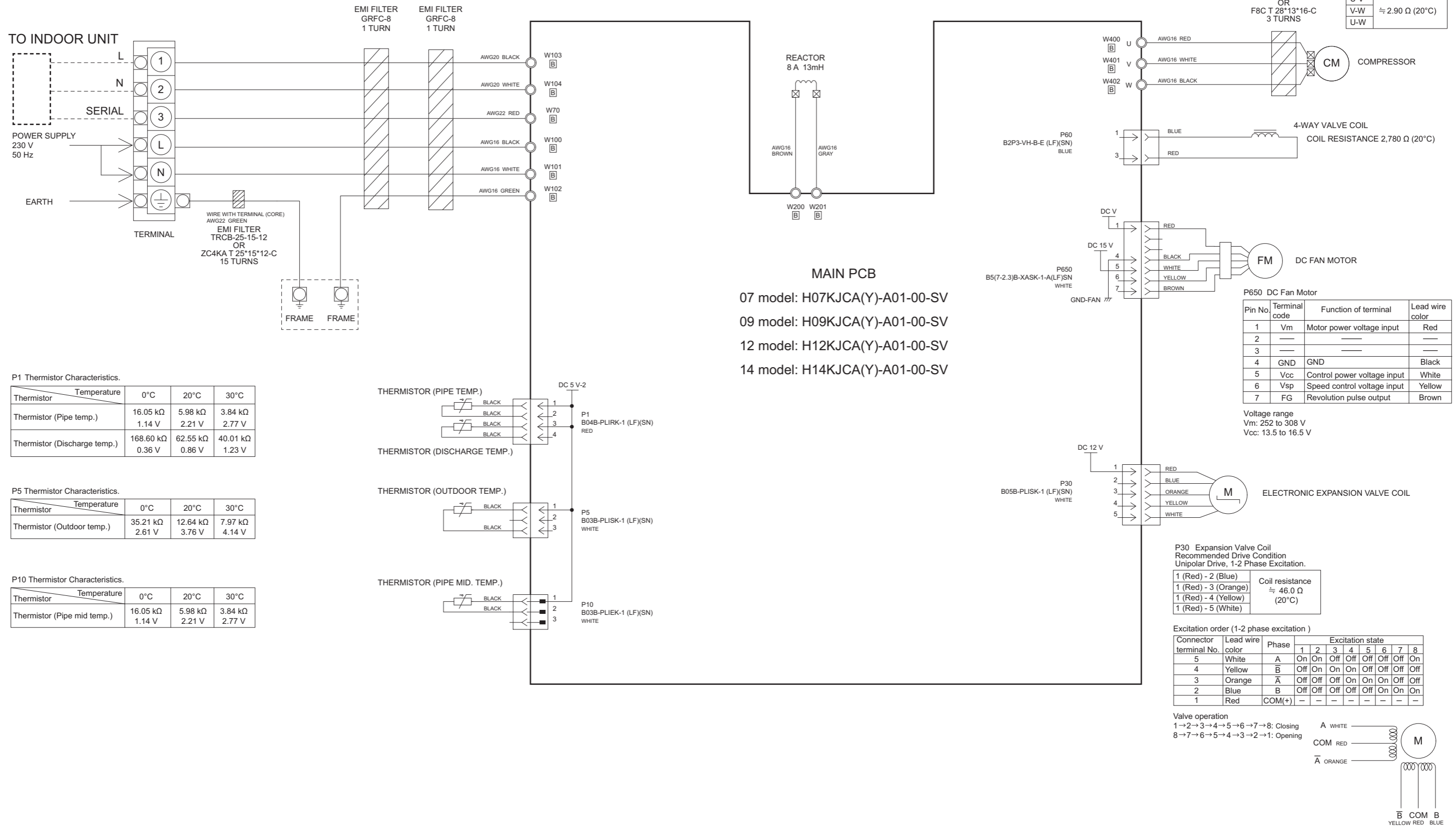

TECHNICAL DATA AND PARTS LIST

TECHNICAL DATA AND PARTS LIST

3. TROUBLESHOOTING

CONTENTS

3. TROUBLESHOOTING

1. Error code	03-1
1-1. How to check the error memory.....	03-1
1-2. How to erase the error memory	03-1
1-3. Error codes and indicators.....	03-2
1-4. Error code table (Wireless LAN indicator).....	03-6
1-5. How to check the error code on Mobile app	03-7
1-6. Error code table (Mobile app)	03-8
1-7. Error message for wireless LAN control (Mobile app).....	03-11
2. Troubleshooting	03-25
2-1. Troubleshooting with error code	03-25
2-2. Troubleshooting without error code	03-61
2-3. Troubleshooting with error code (For wireless LAN adapter).....	03-68
3. Service parts information	03-76
3-1. Compressor	03-76
3-2. Inverter compressor.....	03-77
3-3. Outdoor unit Electronic Expansion Valve (EEV)	03-78
3-4. Indoor unit fan motor	03-80
3-5. Outdoor unit fan motor.....	03-81
3-6. Reactor assy.....	03-82
3-7. 4-way valve coil (solenoid coil)/4-way valve	03-83
4. Thermistor resistance values.....	03-84
4-1. Indoor unit	03-84
4-2. Outdoor unit.....	03-85

1. Error code

When a problem occurs in the system or the connected device, the error content is notified by displaying the code.

NOTE: This function is only available in a system with indoor or IR receiver units equipped with indicator lamps to show the error content.

Errors, once displayed, will be automatically stored in the PC board of the indoor unit. Even if the power is disconnected, the memory containing the error history will not be erased.

If another error occurs later, the stored error memory will be updated automatically and replaced with the new one. (Previous error will be erased.)

1-1. How to check the error memory

When an error occurs, the operation lamp (Green) and the timer lamp (Orange) indicate the error content by blinking. To check the error memory, follow the procedures below.

1. Stop the operation of the air conditioner, and then disconnect the power supply.
2. Reconnect the power supply.
3. In one of the following two methods, the memorized error is only displayed during the “3 minutes ST”^{*} state period.
 - Start the operation and then press the TEST RUN button on the remote controller.
 - Press the MANUAL AUTO button on the indoor unit for 10 seconds or more.

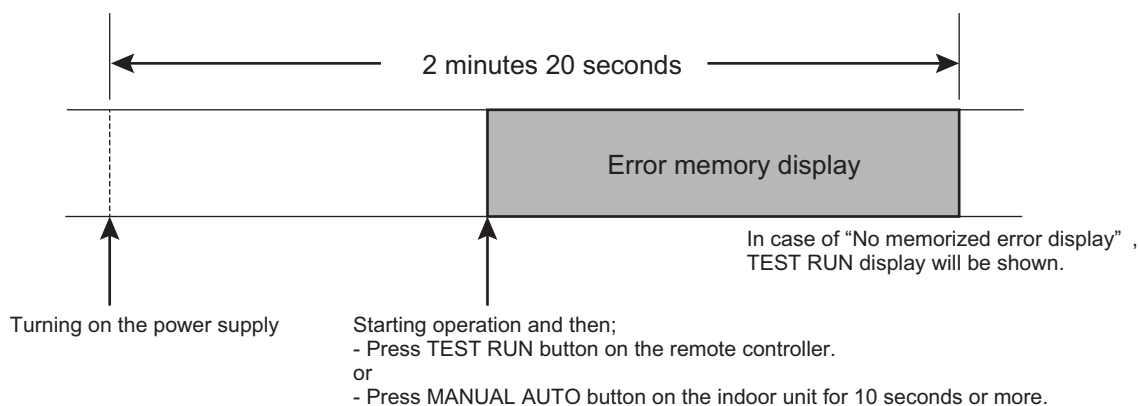

*: The “3 minutes ST” period lasts 2 minutes and 20 seconds after turning on the power supply.

1-2. How to erase the error memory

The error memory can be erased in one of the following two methods.

- Manual erase: Pressing the MANUAL AUTO button on the indoor unit while the “Error memory display” is being shown. (Short beep emits for about 3 seconds.)
- Automatic erase: After continuing the normal operation of the air conditioner without error for 2 hours or longer after displaying the error memory as described in [How to check the error memory](#). (Except FAN operation mode.)

1-3. Error codes and indicators





When the system detects an error, the indicator lamps on the indoor unit, outdoor unit, or IR Receiver Unit flash in a specific pattern to indicate the type of the error. If there is a remote controller connected to the system, it shows the corresponding error code on its display.

● Indoor unit or IR Receiver Unit indicator lamps and displayed code on the Wired Remote Controller (if connected)

The operation, timer, and economy indicator lamps inform you of the error with the associated blinking pattern.

The blinks described in a number in the following table are on for 0.5 seconds and off for 0.5 seconds. Fast blinks repeat blinks 0.1 seconds on and 0.1 seconds off.









Error	Number or speed or blinks of the indicator lamp			Error code
	Operation 	Timer ⌚	Economy 🏠	
	● Green	● Orange	● Green	
E: 11. Serial communication error (Serial forward transfer error)	1	1	Fast blinks	11
E: 12. Wired remote controller communication error	1	2	Fast blinks	12
E: 15. Automatic airflow adjustment error	1	5	Fast blinks	15
E: 18. External communication error	1	8	Fast blinks	18
E: 22. Indoor unit capacity error	2	2	Fast blinks	22
E: 23. Refrigerant combination error	2	3	Fast blinks	23
E: 26. Wired remote controller address setting error	2	6	Fast blinks	26
E: 29. Connected unit number error	2	9	Fast blinks	29
E: 32. Indoor unit Main PCB error	3	2	Fast blinks	32
E: 33. Indoor unit motor electricity consumption detection error	3	3	Fast blinks	33
E: 35. MANUAL AUTO button error	3	5	Fast blinks	35
E: 39. Power supply error of indoor unit fan motor	3	9	Fast blinks	39
E: 3A. Indoor unit communication circuit error	3	10	Fast blinks	3A
E: 41 / 42. Indoor unit thermistor error	4	1	Fast blinks	41
E: 41 / 42. Indoor unit thermistor error	4	2	Fast blinks	42
E: 44. Human sensor error	4	4	Fast blinks	44
E: 51. Indoor unit fan motor error	5	1	Fast blinks	51
E: 62. Outdoor unit Main PCB communication error	6	2	Fast blinks	62
E: 63. Inverter error	6	3	Fast blinks	63









Error	Number or speed or blinks of the indicator lamp			Error code
	Operation 	Timer 	Economy 	
	 Green	 Orange	 Green	
E: 64. PFC circuit error	6	4	Fast blinks	64
E: 65. IPM error	6	5	Fast blinks	65
E: 71 / 72 / 73 / 74 / 76 / 77. Outdoor unit thermistor error	7	1	Fast blinks	71
E: 71 / 72 / 73 / 74 / 76 / 77. Outdoor unit thermistor error	7	2	Fast blinks	72
E: 71 / 72 / 73 / 74 / 76 / 77. Outdoor unit thermistor error	7	3	Fast blinks	73
E: 71 / 72 / 73 / 74 / 76 / 77. Outdoor unit thermistor error	7	4	Fast blinks	74
E: 84. Current sensor error	8	4	Fast blinks	84
E: 94. Trip detection	9	4	Fast blinks	94
E: 95. Compressor motor control error	9	5	Fast blinks	95
E: 97 / 98. Outdoor unit fan motor error	9	7	Fast blinks	97
E: 99. 4-way valve error	9	9	Fast blinks	99
E: A1. Discharge temperature error	10	1	Fast blinks	A1

● Outdoor unit indicator lamps and displayed code

The ERROR indicator lamp blinks at a high speed when an error occurs. To enter the error display mode to check the individual error, press the ENTER button once.

Then, the ERROR indicator lamp lights on, and other indicator lamps inform you of the operation status and the error with the associated blinking pattern.

Error	Lighting on/off or number of blinks								Error code
	POWER MODE	ERROR	PUMP DOWN	LOW NOISE		PEAK CUT			
			 L 1		 L 3	 L 4	 L 5	 L 6	
Green	Red	Orange	Orange		Orange				
E: 11. Serial communication error (Serial forward transfer error) (Occurs immediately after starting operation)	2	On	1	1	Off	Off	On	On	11
E: 11. Serial communication error (Serial forward transfer error) (Occurs during operation)	2	On	1	1	Off	On	Off	Off	11
E: 12. Wired remote controller communication error	2	On	5	15	Off	Off	Off	On	12
E: 15. Automatic airflow adjustment error	2	On	5	15	Off	Off	Off	On	15
E: 18. External communication error	2	On	5	15	Off	Off	Off	On	18
E: 22. Indoor unit capacity error	2	On	2	2	Off	Off	Off	On	22
E: 23. Refrigerant combination error	2	On	2	3	Off	Off	Off	On	23
E: 26. Wired remote controller address setting error	2	On	5	15	Off	Off	Off	On	26
E: 29. Connected unit number error	2	On	5	15	Off	Off	Off	On	29
E: 32. Indoor unit Main PCB error	2	On	5	15	Off	Off	Off	On	32
E: 33. Indoor unit motor electricity consumption detection error	2	On	5	15	Off	Off	Off	On	33
E: 35. MANUAL AUTO button error	2	On	5	15	Off	Off	Off	On	35
E: 39. Power supply error of indoor unit fan motor	2	On	5	15	Off	Off	Off	On	39
E: 3A. Indoor unit communication circuit error	2	On	5	15	Off	Off	Off	On	3A
E: 41 / 42. Indoor unit thermistor error	2	On	5	15	Off	Off	Off	On	41
E: 41 / 42. Indoor unit thermistor error	2	On	5	15	Off	Off	Off	On	42
E: 44. Human sensor error	2	On	5	15	Off	Off	Off	On	44
E: 51. Indoor unit fan motor error	2	On	5	15	Off	Off	Off	On	51
E: 62. Outdoor unit Main PCB communication error	2	On	6	2	Off	Off	Off	On	62

Error	Lighting on/off or number of blinks								Error code
	POWER MODE	ERROR	PUMP DOWN	LOW NOISE		PEAK CUT			
			 L1	 L2	 L3	 L4	 L5	 L6	
Green	Red	Orange	Orange		Orange				
E: 63. Inverter error	2	On	6	3	Off	Off	Off	On	63
E: 65. IPM error	2	On	6	5	Off	Off	Off On	On	65
E: 71 / 72 / 73 / 74 / 76 / 77. Outdoor unit thermistor error	2	On	7	1	Off	Off	Off	On	71
E: 71 / 72 / 73 / 74 / 76 / 77. Outdoor unit thermistor error	2	On	7	2	Off	Off	Off	On	72
E: 71 / 72 / 73 / 74 / 76 / 77. Outdoor unit thermistor error	2	On	7	3	Off	Off	On	Off On	73
E: 71 / 72 / 73 / 74 / 76 / 77. Outdoor unit thermistor error	2	On	7	4	Off	Off	Off	On	74
E: 84. Current sensor error	2	On	8	4	Off	Off	Off	On	84
E: 94. Trip detection	2	On	9	4	Off	Off	Off	On	94
E: 95. Compressor motor control error	2	On	9	5	Off	Off	Off	On	95
E: 97 / 98. Outdoor unit fan motor error	2	On	9	7	Off	Off	On	Off	97
E: 99. 4-way valve error	2	On	9	9	Off	Off	Off	On	99
E: A1. Discharge temperature error	2	On	10	1	Off	Off	Off	On	A1

TROUBLESHOOTING

TROUBLESHOOTING

1-4. Error code table (Wireless LAN indicator)

- Wireless LAN control system diagram example

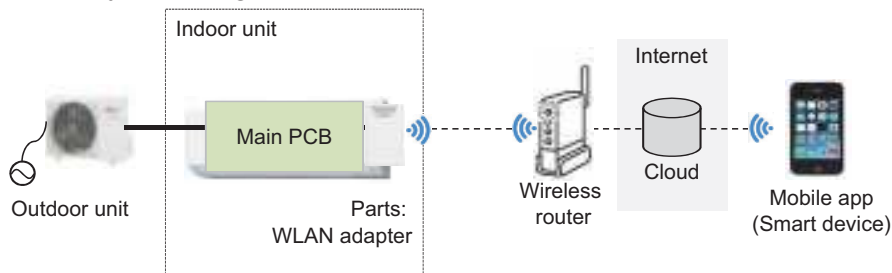

- Name of parts

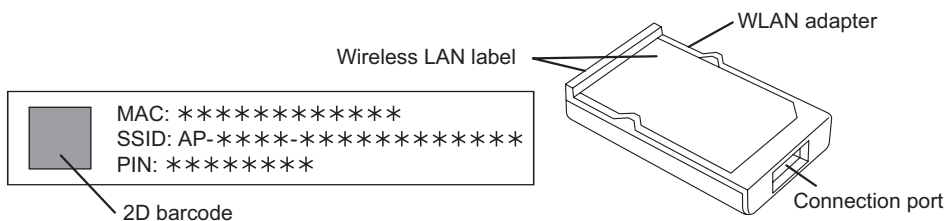

- Wireless LAN indicator lamps

For confirmation of the error contents, refer to the following flashing patterns.

Wireless LAN indicator lamp (orange) on the indoor unit operate according to the error contents.

Error contents	Wireless LAN indicator lamp (orange)	Error code
E: 18. External communication error between indoor unit and wireless LAN adapter	Flashing slowly	18
Network communication error between wireless LAN router and wireless LAN adapter	Flashing slowly	No error
E: 18. Communication error	Flashing slowly	18
E: 18. Wireless LAN adapter non-energized	Off	18

Flashing slowly: Repeating 7 seconds on/2 seconds off

TROUBLESHOOTING

TROUBLESHOOTING

1-5. How to check the error code on Mobile app

If there is an abnormality on the air conditioning, refer to  as follows.

When the  (error button) on the home screen is tapped, error code and error name is displayed.

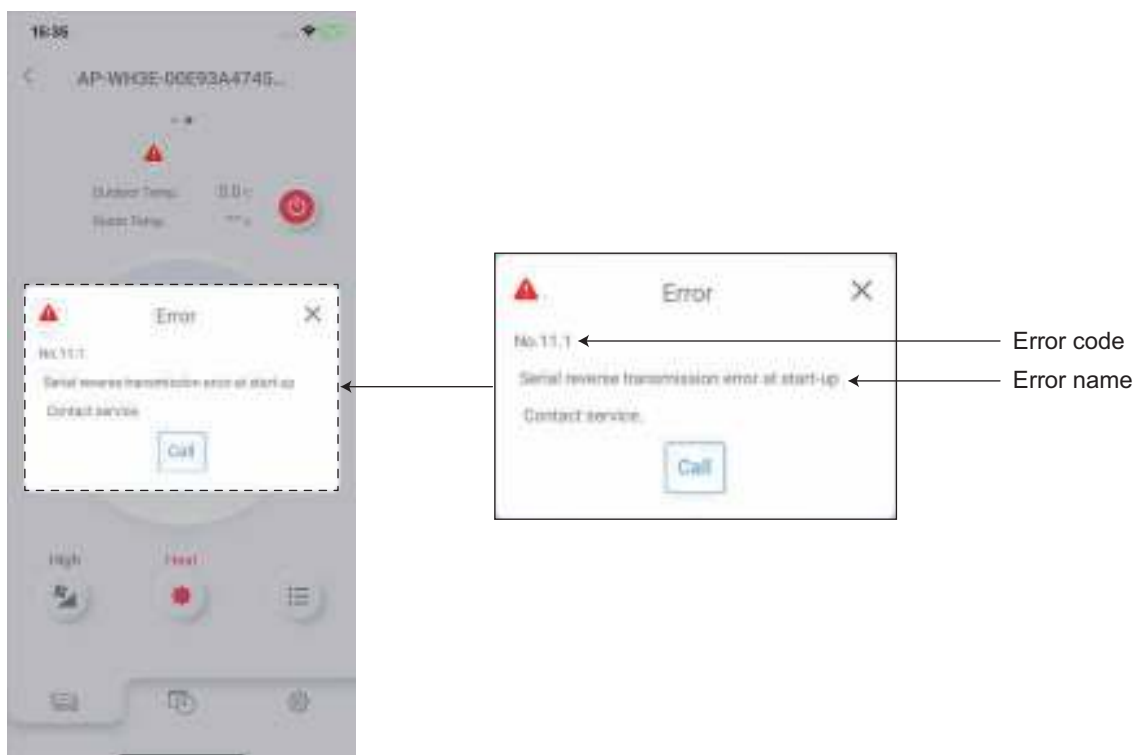
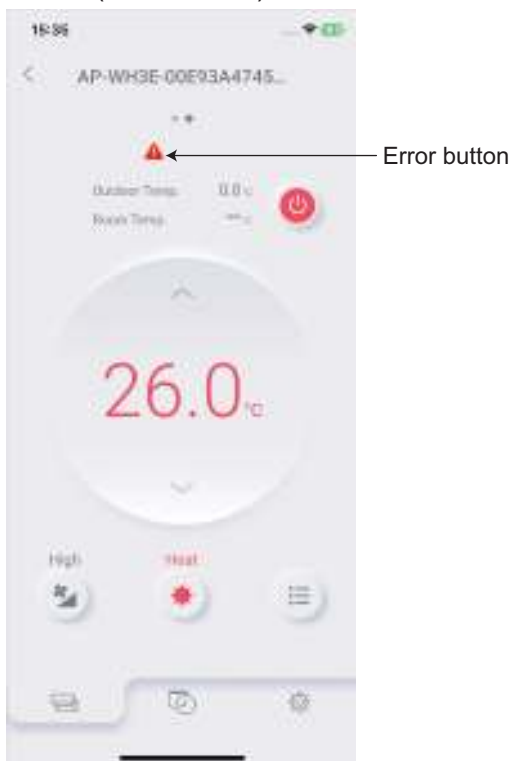

1-6. Error code table (Mobile app)

Error code	Error message	Error contents
11.3	Serial forward transmission error at start-up	E: 11. Serial communication error (Serial forward transfer error)
11.4	Serial forward transmission error during operation	
12.1	Wired remote controller communication error	E: 12. Wired remote controller communication error
12.2	Wired remote controller signal error	
12.3	Excess number of devices in wired remote controller system	
12.4	Wired remote controller system start-up error	
15.1	Scan error of initial setting data	E: 15. Automatic airflow adjustment error
15.2	Number of indoor units excessive (400 exceeded)	
15.3	Number of outdoor units excessive (100 exceeded)	
15.4	Configuration data acquisition error during scan	
15.5	Scan setting range error	
15.6	Check run unfinished	
18.1	External communication 1 error	E: 18. External communication error
22.1	Indoor unit capacity error	E: 22. Indoor unit capacity error
23.1	Connection forbidden (series error)	E: 23. Refrigerant combination error
23.2	Unit combination error	
26.1	Indoor unit duplicate address error	E: 26. Wired remote controller address setting error
26.2	Refrigerant circuit address setting error	
26.3	Node address setting error	
26.4	Address duplication in wired remote controller system	
26.5	Address setting error in wired remote controller system	
29.1	Connection unit number error (indoor unit in wired remote controller system)	E: 29. Connected unit number error
29.2	Connection unit number error (Remote controller)	
32.1	Indoor unit PCB model information error	E: 32. Indoor unit Main PCB error
32.2	Microcomputers communication error	
32.3	Indoor unit EEPROM access error	
32.4	Indoor unit main PCB EEPROM erase error	
32.5	Watchdog operation (indoor unit)	
32.6	Constant correction control error	
32.7	Indoor unit microcomputer self-check error	
33.1	Indoor unit display microcomputers error	E: 33. Indoor unit motor electricity consumption detection microcomputers error
33.2	Indoor unit motor electricity consumption detection microcomputers error	
33.3	Indoor unit actuator extensions microcomputers error	
35.1	Indoor unit manual auto switch error	E: 35. MANUAL AUTO button error
39.1	Indoor unit power supply error for fan motor 1	E: 39. Power supply error of indoor unit fan motor
39.2	Indoor unit power supply error for fan motor 2	
39.3	Indoor unit power supply error of AC24V system	
3A.1	Indoor unit communication circuit (wired remote controller) microcomputers communication error	E: 3A. Indoor unit communication circuit error
41.1	Indoor unit suction air temp. thermistor error	E: 41 / 42. Indoor unit thermistor error
41.2	Indoor unit discharge air temp. thermistor error	
42.1	Indoor unit heat ex. inlet temp. thermistor error	
42.2	Indoor unit heat ex. middle temp. thermistor error	
42.3	Indoor unit heat ex. outlet temp. thermistor error	E: 44. Human sensor error
44.1	Human detection sensor error	
44.2	Thermopile error	
44.3	Photo-conduction sensor error	

Error code	Error message	Error contents
51.1	Indoor unit fan motor 1 lock error	E: 51. Indoor unit fan motor error
51.2	Indoor unit fan motor 1 rotation speed error	
51.3	Indoor unit sub fan motor lock error	
51.4	Indoor unit sub fan motor rotation speed error	
51.5	Indoor unit fan motor 1 communication error	
51.6	Indoor unit fan motor 1 self judgment error	
51.7	Indoor unit fan motor 1 model error	
62.1	Outdoor unit PCB model information error	E: 62. Outdoor unit Main PCB communication error
62.2	Outdoor unit PCB microcomputer communication error	
62.3	Outdoor unit EEPROM access error	
62.4	Outdoor unit main PCB EEPROM erase error	
62.5	Watchdog operation (outdoor unit)	
62.6	Outdoor unit inverters communication error	
62.7	PFC communication error	
62.8	Outdoor unit EEPROM data corruption error	
62.9	Outdoor unit microcomputer self-check error	
62.A	Outdoor unit inverters 2 communication error	E: 63. Inverter error
63.1	Outdoor unit inverter error	
63.2	Electrolytic capacitor error	
63.3	Outdoor unit inverter 2 error	E: 64. PFC circuit error
64.1	Outdoor unit abnormal voltage error (permanent stop)	
64.2	Module error	
64.3	Outdoor unit abnormal voltage error (automatic restore)	
64.4	Outdoor unit over current error (permanent stop)	
64.5	PFC power supply interrupted error	
64.6	Over current protection (restartable)	
64.7	PFC AD detection error	
64.8	Outdoor unit PFC hardware error	E: 65. IPM error
65.1	Temperature abnormal	
65.2	Current abnormal	
65.3	Outdoor unit trip terminal L error	E: 71 / 72 / 73 / 74 / 76 / 77. Outdoor unit thermistor error
71.1	Outdoor unit discharge temp. thermistor 1 error	
71.2	Outdoor unit discharge temp. thermistor 2 error	
72.1	Outdoor unit compressor temp. thermistor 1 error	
72.2	Outdoor unit compressor temp. thermistor 2 error	
73.1	Outdoor unit heat ex. inlet temp. thermistor error	
73.2	Outdoor unit heat ex. middle temp. thermistor error	
73.3	Outdoor unit heat ex. liquid temp. thermistor error	
73.4	Outdoor unit heat ex. 1 gas temp. thermistor error	
73.5	Outdoor unit heat ex. 1 liquid temp. thermistor error	
73.6	Outdoor unit heat ex. 2 gas temp. thermistor error	
73.7	Outdoor unit heat ex. 2 liquid temp. thermistor error	
74.1	Outside air temp. thermistor error	
76.1	Outdoor unit 2-way valve temp. thermistor error	
76.2	Outdoor unit 3-way valve temp. thermistor error	
77.1	Outdoor unit heat sink temp. thermistor error	
77.2	Outdoor unit PFC heat sink temp. thermistor error	
77.3	Outdoor unit heat sink temp. thermistor 1 error	E: 84. Current sensor error
84.1	Outdoor unit current sensor 1 error (permanent stop)	
84.2	Outdoor unit current sensor 1 error (automatic restore)	
84.3	Outdoor unit current sensor 2 error (permanent stop)	
84.4	Outdoor unit current sensor 2 error (automatic restore)	
84.5	U phase current sensor error	
84.6	V phase current sensor error	

Error code	Error message	Error contents
94.1	Outdoor unit trip detection	E: 94. Trip detection
94.2	Reverse current trip (restore)	
94.3	Outdoor unit trip detection 2	
95.1	Outdoor unit compressor rotor position detection error (permanent stop)	E: 95. Compressor motor control error
95.2	Outdoor unit compressor rotor position detection error (automatic restore)	
95.3	Outdoor unit compressor speed error	
95.4	Compressor reverse phase, open phase error	
95.5	Outdoor unit compressor motor loss of synchronization	
95.6	Outdoor unit compressor 2 motor loss of synchronization	
97.1	Outdoor unit fan motor 1 lock error	E: 97 / 98. Outdoor unit fan motor error
97.2	Outdoor unit DC fan motor 1 error (permanent stop)	
97.3	Outdoor unit fan motor 1 power source duty error	
97.4	Outdoor unit fan motor 1 under-voltage error	
97.5	Outdoor unit fan motor 1 temperature error (protective action)	
97.6	Rotation speed protected operation	
97.7	Strong wind running protected operation	
97.8	Fan motor HIC temperature sensor error	
97.9	Outdoor unit fan motor 1 driver error	
99.1	Outdoor unit 4-way valve error	E: 99. 4-way valve error
99.2	Retry protected operation	
A1.1	Outdoor unit discharge temperature 1 error (permanent stop)	E: A1. Discharge temperature error
A1.2	Outdoor unit discharge temperature 1 error (automatic restore)	
A1.3	Discharge temperature 1 release stoppage	

1-7. Error message for wireless LAN control (Mobile app)

■ Error display

If there is an abnormality on the wireless control system, refer to error messages as follows.

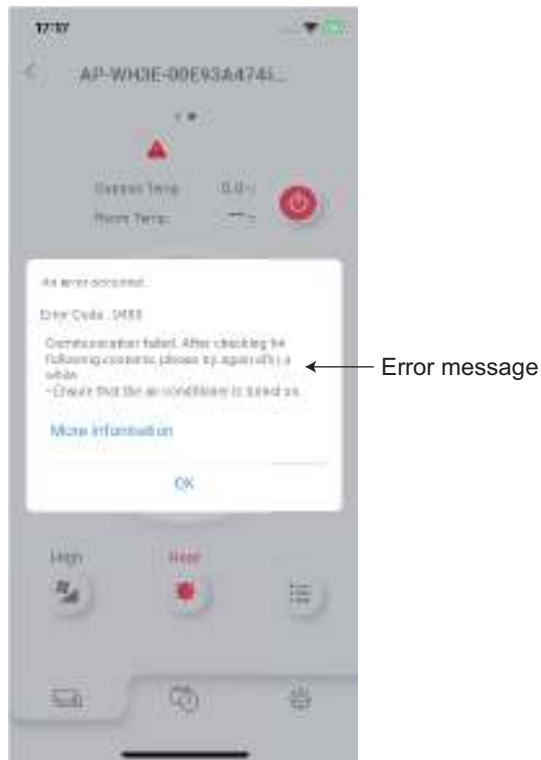

■ Error message list

- Registration error

Error code	Error message	Cause
		Solution
2400	<p>Communication failed. After checking the following contents, please try again after a while.</p> <ul style="list-style-type: none"> • Ensure that the air conditioner is turned on. 	<p>Communication with the air conditioner failed.</p> <p>Check the following contents depending on the status of indoor unit wireless LAN indicator lamp or WLAN Adapter LED 2 and operate again.</p> <ul style="list-style-type: none"> • When not lighting <ul style="list-style-type: none"> – Check that the Electrical panel (Switch breaker) to the air conditioner is turned on. – Check that the power plug of the air conditioner main unit is plugged in. • When lighting <p>Use a smartphone to check that the wireless router to which the air conditioner is connected is connected to the Internet. If the smartphone cannot connect to the Internet, reboot the wireless router. When rebooting the wireless router does not solve the problem, contact the manufacturer of the wireless router.</p> • When blinking <p>Wait for a while until the indicator lamp lights and then operate again. If the indicator lamp is still blinking after waiting for a while, check that the wireless router is turned on.</p>
		<p>Failed because the smartphone could not connect to the air conditioner.</p> <p>Check the following contents depending on the status of indoor unit wireless LAN indicator lamp or WLAN Adapter LED 2 and operate again.</p> <ul style="list-style-type: none"> • When not lighting <ol style="list-style-type: none"> 1. Check that the 2D barcode is for the air conditioner to be registered. 2. Check that the Electrical panel (Switch breaker) to the air conditioner is turned on. 3. Check that the power plug of the air conditioner main unit is plugged in. 4. Retry the connection step procedure for the air conditioner registration displayed in the application to set the lamp to the blinking state. • When lighting or blinking <ol style="list-style-type: none"> 1. Check that the 2D barcode is for the air conditioner to be registered. 2. Check that the wireless LAN setting of smartphone is set to ON.
2930	<p>Cannot connect to your air conditioner. Check if the WiFi setting of the mobile device is turned on.</p> <p>When problems are not resolved, there may be other causes. Tap the link below to check other solutions.</p>	<p>Failed because the smartphone could not connect to the air conditioner.</p> <p>Check the following contents depending on the status of indoor unit wireless LAN indicator lamp or WLAN Adapter LED 2 and operate again.</p> <ul style="list-style-type: none"> • When not lighting <ol style="list-style-type: none"> 1. Check that the 2D barcode is for the air conditioner to be registered. 2. Check that the Electrical panel (Switch breaker) to the air conditioner is turned on. 3. Check that the power plug of the air conditioner main unit is plugged in. 4. Retry the connection step procedure for the air conditioner registration displayed in the application to set the lamp to the blinking state. • When lighting or blinking <ol style="list-style-type: none"> 1. Check that the 2D barcode is for the air conditioner to be registered. 2. Check that the wireless LAN setting of smartphone is set to ON.
		<p>Failed because the smartphone could not connect to the air conditioner.</p> <p>Check the following contents depending on the status of indoor unit wireless LAN indicator lamp or WLAN Adapter LED 2 and operate again.</p> <ul style="list-style-type: none"> • When not lighting <ol style="list-style-type: none"> 1. Check that the 2D barcode is for the air conditioner to be registered. 2. Check that the Electrical panel (Switch breaker) to the air conditioner is turned on. 3. Check that the power plug of the air conditioner main unit is plugged in. 4. Retry the connection step procedure for the air conditioner registration displayed in the application to set the lamp to the blinking state. • When lighting or blinking <ol style="list-style-type: none"> 1. Check that the 2D barcode is for the air conditioner to be registered. 2. Check that the wireless LAN setting of smartphone is set to ON.

Error code	Error message	Cause
		Solution
2931	WLAN adapter password is wrong. Enter it again. When problems are not resolved, there may be other causes. Tap the link below to check other solutions.	Failed because the smartphone could not connect to the air conditioner. Check the following contents depending on the status of indoor unit wireless LAN indicator lamp or WLAN Adapter LED 2 and operate again.
		<ul style="list-style-type: none"> • When not lighting <ol style="list-style-type: none"> 1. Check that the Electrical panel (Switch breaker) to the air conditioner is turned on. 2. Check that the power plug of the air conditioner main unit is plugged in. 3. Retry the connection step procedure for the air conditioner registration displayed in the application to set the lamp to the blinking state. • When lighting or blinking <ol style="list-style-type: none"> 1. Check that the entered SSID and PIN numbers of WLAN Adapter are correct. 2. Check that the wireless LAN setting of smartphone is set to ON.
2932 2933	Failed to connect to wireless router. Check if the WiFi setting of the mobile device is turned on. When problems are not resolved, there may be other causes. Tap the link below to check other solutions.	<ul style="list-style-type: none"> • Registration failed because the smartphone cannot connect to the network. • Connection to the WLAN Adapter was disconnected during processing.
		<ol style="list-style-type: none"> 1. Check that the wireless LAN setting of smartphone is set to ON. 2. Check that the smartphone is connected to the Internet.
2934	Wi-Fi router password is wrong. Tap “From the beginning” to enter it again. When problems are not resolved, there may be other causes. Tap the link below to check other solutions.	<ul style="list-style-type: none"> • The wireless router password is not correct. • The air conditioner is not connected to the same wireless router as the smartphone.
		Check the following contents and operate again. <ol style="list-style-type: none"> 1. Check that the wireless router password is correct. 2. Check that the smartphone and the air conditioner are connected to the same wireless router. 3. The wireless router encryption method WPA3 is not supported. Check if SSID other than WPA3 is selected. 4. Check that the local network setting of the smartphone is “Enabled”. (Only for smartphones with iOS14 or later)
2935 2937 2939 2941	Failed to register the air conditioner. Make sure the wireless router is connected to the Internet, and then tap “Re-register” to perform the registration process again. When problems are not resolved, there may be other causes. Tap the link below to check other solutions.	Registration failed because the air conditioner cannot connect to the Internet.
		Check the following contents and operate again. <ol style="list-style-type: none"> 1. Use a smartphone to check that the wireless router to which the air conditioner is connected is connected to the Internet. 2. If the smartphone cannot connect to the Internet, reboot the wireless router. When rebooting the wireless router does not solve the problem, contact the manufacturer of the wireless router. 3. Check that the MAC address filter and privacy separator settings are not “enabled” on the wireless router.

Error code	Error message	Cause
		Solution
2936 2940	Air conditioner registration failed. Tap "Re-register" and conduct the registration processing again. If not successful after multiple attempts, tap "From the beginning" and then initialize the WLAN and start over from the beginning.	<ul style="list-style-type: none"> The air conditioner you are trying to register is already registered to another account. Registration failed because the air conditioner cannot connect to the Internet. Immediately after turning on the power of the air conditioner, wait for about 5 minutes before registering it. <p>Check the following contents and operate again.</p> <ol style="list-style-type: none"> Tap "Re-register" and conduct the registration processing again. Delete from another account or initialize the WLAN Adapter. Check that the wireless router is turned on. Check that wireless router is connected to the Internet. If not connected, reboot the wireless router. When rebooting does not solve the problem, contact the manufacturer of the wireless router. Check that the MAC address filter and privacy separator settings are not "enabled" on the wireless router.
2938	Registration failed because the air conditioner could not connect to the Internet. Perform the WPS connection procedure again and confirm that the WLAN lamp on the indoor unit or LED2 on the WLAN adapter is lit before registering. When problems are not resolved, there may be other causes. Tap the link below to check other solutions.	<ul style="list-style-type: none"> Registration failed because the air conditioner cannot connect to the Internet. Registration failed because the air conditioner is not connected to the same wireless router as the smartphone. <p>Check the following contents depending on the status of indoor unit wireless LAN indicator lamp or WLAN Adapter LED 2 and operate again.</p> <ul style="list-style-type: none"> When not lighting <ol style="list-style-type: none"> Check that the Electrical panel (Switch breaker) to the air conditioner is turned on. Check that the power plug of the air conditioner main unit is plugged in. Check that the wireless router is turned on. Retry the connection step procedure for the air conditioner registration displayed in the application and complete WPS connection with wireless router to set the lamp to the blinking state. When lighting <ol style="list-style-type: none"> Check that the air conditioner and the smartphone are connected to the same wireless router. Check that the local network setting of the smartphone is "Enabled". (Only for smartphones with iOS14 or later)
2942	Your mobile device is not connected to WiFi. Connect to the target wireless router through the OS WiFi setting and restart the procedure. <ol style="list-style-type: none"> Open the Wi-Fi setting screen of your device. Connect your mobile device to the {ssid}. Return to the application screen and tap "Re-register". <p>When problems are not resolved, there may be other causes. Tap the link below to check other solutions.</p>	<p>Registration failed because the air conditioner cannot connect to the Internet.</p> <p>Check the following contents and operate again.</p> <ol style="list-style-type: none"> Check that the wireless LAN setting of smartphone is set to ON. Check that the smartphone is connected to the Internet. Set the connection setting with the wireless router to Auto Connection in the smartphone settings. Check that the wireless router is turned on.

Error code	Error message	Cause
		Solution
2944	Communication failed.	Registration may have failed because a problem occurred in communication with the server (cloud). Wait for a while and then operate again.
2946	The connected air conditioner cannot use the Direct control.	Your air conditioner does not support Direct Control. Operate the air conditioner with Cloud Control.
2947	Already reached the max number of air conditioners per user.	The number of air conditioners that can be registered on AIRSTAGE Mobile has reached the maximum limit. Check the number of air conditioners registered on AIRSTAGE Mobile. (Maximum number of registered units: 50 units for Cloud Control, 50 units for Direct Control) Delete the unused air conditioners on the "Air conditioner editing" screen before registration.
2949	The number of air conditioners registered by the entered user has reached the upper limit, so registration is not possible.	The number of sub users that can be registered has reached the maximum limit. Check the number of registered sub users. (Maximum number of registered sub users: 4 sub users) Delete the unused sub users on the "Sub User Registration" screen.
2953	The specified air conditioner is already registered. To Reregister, delete the air conditioner information on the air conditioner edit screen and initialize the wireless LAN adapter with the remote control.	The specified air conditioner was already registered. Check that the specified air conditioner is displayed on the air conditioner list screen. To register again, delete the air conditioner on the air conditioner editing screen.
2954	The wireless router to which the mobile device and the wireless LAN adapter are connected must be the same. Follow the steps below. 1. Please open the Wi-Fi setting screen of the mobile device. 2. Connect your mobile device to the wireless router that you pressed the automatic connection button. 3. Return to the app screen and tap "OK".	The air conditioner and the smartphone are not connected to the same wireless router network. Check the following contents and operate again. 1. Check that the wireless LAN setting of smartphone is set to ON. 2. Check that the smartphone is connected to the Internet. 3. Check that the wireless router is turned on. 4. Check that the air conditioner and the smartphone are connected to the same wireless router.

• Sign in error

Error code	Error message	Cause
		Solution
4010 4410 4610 4810 4910	Communication failed. After checking the following contents, please try again after a while. • Ensure that your mobile device is connected to the internet.	Various settings could not be completed because communication with the server (cloud) failed.
		Check the following contents and operate again. 1. Check that the wireless LAN setting of smartphone is set to ON. 2. Check that the smartphone is connected to the Internet. 3. Check that the wireless router is turned on.
4100	The account you are currently signed in to may have been deleted. If necessary, please create the account again.	Token has been disabled because the signed-in account has been deleted or certain amount of time has elapsed.
		Restart the application and check that you can sign in. If you cannot sign in, create the account again.
4101	The session has expired. Please sign in again to continue.	Token has been disabled because the signed-in account has been deleted or certain amount of time has elapsed.
		Restart the application and check that you can sign in. If you cannot sign in, create the account again.
4102	Your session has expired. Please sign in again. *If you cannot sign in, your account may have been deleted. If necessary, please create an account again.	Token has been disabled because the signed-in account has been deleted or certain amount of time has elapsed.
		Restart the application and check that you can sign in. If you cannot sign in, create the account again.
4110	Failed to connect to the server. Some functions can be used with Direct Control. Do you want to switch to direct control?	• Communication with the server (cloud) failed at sign in. • Registration process of Account registration procedure verification email has not been completed.
		Check the following contents and sign in again. 1. Check that the wireless LAN setting of smartphone is set to ON. 2. Check that the smartphone is connected to the Internet. 3. Check that the wireless router is turned on. 4. Tap the link of Account registration procedure verification email and check that registration process has completed.
4111	Failed to read the device. Since some functions are available in Direct control, switch to Direct control.	Air conditioner information could not be obtained because communication with the server (cloud) failed after sign in.
		Check the following contents and sign in again. 1. Check that the wireless LAN setting of smartphone is set to ON. 2. Check that the smartphone is connected to the Internet. 3. Check that the wireless router is turned on.
4112	Failed to connect to the server. Some functions are limited.	• Communication with the server (cloud) failed at sign in. • Registration process of Account registration procedure verification email has not been completed.
		Check the following contents and sign in again. 1. Check that the wireless LAN setting of smartphone is set to ON. 2. Check that the smartphone is connected to the Internet. 3. Check that the wireless router is turned on. 4. Tap the link of Account registration procedure verification email and check that registration process has completed.
4113	Failed to connect to the server. Would you like to sign in again? Yes: Sign in again No: Return to the sign-in screen	Air conditioner information could not be obtained because communication with the server (cloud) failed after sign in.
		Check the following contents and sign in again. 1. Check that the wireless LAN setting of smartphone is set to ON. 2. Check that the smartphone is connected to the Internet. 3. Check that the wireless router is turned on.

Error code	Error message	Cause
		Solution
4420	Loading of user information failed. Check the following contents. <ul style="list-style-type: none"> Check that your mobile device is connected to the internet. 	User information or temperature unit information could not be obtained because communication with the server (cloud) failed.
		Check the following contents and operate again. <ol style="list-style-type: none"> Check that the wireless LAN setting of smartphone is set to ON. Check that the smartphone is connected to the Internet. Check that the wireless router is turned on.
4530	Password update failed. Please check if the entered current password is correct.	Password update failed because the entered password was not correct.
		Check that the entered "Current password" is correct and operate again.
4920	Loading of time zone failed. Check the following contents. <ul style="list-style-type: none"> Check that your mobile device is connected to the internet. 	Time zone information could not be obtained because communication with server (cloud) failed.
		Check the following contents and operate again. <ol style="list-style-type: none"> Check that the wireless LAN setting of smartphone is set to ON. Check that the smartphone is connected to the Internet. Check that the wireless router is turned on.

- General error

Error code	Error message	Cause
		Solution
0100 0200 0300 0400 0500 0501 0600 0601 0800 0900 1000 1200 1400 1500 3200 5500 5700 5900 6200	Communication failed. After checking the following contents, please try again after a while. <ul style="list-style-type: none"> • Ensure that the air conditioner is turned on. 	<p>Communication with the air conditioner failed.</p> <p>Check the following contents depending on the status of indoor unit wireless LAN indicator lamp or WLAN Adapter LED 2 and operate again.</p> <ul style="list-style-type: none"> • When not lighting <ul style="list-style-type: none"> – Check that the Electrical panel (Switch breaker) to the air conditioner is turned on. – Check that the power plug of the air conditioner main unit is plugged in. • When lighting <p>Use a smartphone to check that the wireless router to which the air conditioner is connected is connected to the Internet. If the smartphone cannot connect to the Internet, reboot the wireless router. When rebooting the wireless router does not solve the problem, contact the manufacturer of the wireless router.</p>
0810 0811 0812 1510 1511 1512 3010 5510 5520 5530 6001 6002 6003 6010 6011 6012 6013 6310	Communication failed. After checking the following contents, please try again after a while. <ul style="list-style-type: none"> • Ensure that your mobile device is connected to the internet. 	<ul style="list-style-type: none"> • Various settings could not be completed because communication with the server (cloud) failed. • Air conditioner information could not be obtained because communication with server (cloud) failed. <p>Check the following contents and operate again.</p> <ol style="list-style-type: none"> 1. Check that the wireless LAN setting of smartphone is set to ON. 2. Check that the smartphone is connected to the Internet. 3. Check that the wireless router is turned on.

Error code	Error message	Cause
		Solution
0820	<p>Loading of outdoor low noise timer failed. Check the following contents.</p> <ul style="list-style-type: none"> Ensure that your mobile device is connected to the internet. 	<p>The outdoor unit low noise timer information could not be obtained because communication with the server (cloud) failed.</p> <p>Check the following contents depending on the status of indoor unit wireless LAN indicator lamp or WLAN Adapter LED 2 and operate again.</p> <ul style="list-style-type: none"> When not lighting <ul style="list-style-type: none"> Check that the Electrical panel (Switch breaker) to the air conditioner is turned on. Check that the power plug of the air conditioner main unit is plugged in. When lighting <p>Use a smartphone to check that the wireless router to which the air conditioner is connected is connected to the Internet. If the smartphone cannot connect to the Internet, reboot the wireless router. When rebooting the wireless router does not solve the problem, contact the manufacturer of the wireless router.</p> When blinking <p>Wait for a while until the indicator lamp lights and then operate again. If the indicator lamp is still blinking after waiting for a while, check that the wireless router is turned on.</p>
1520	<p>Loading of weekly timer failed. Check the following contents.</p> <ul style="list-style-type: none"> Ensure that your mobile device is connected to the internet. 	<p>The weekly timer setting information could not be obtained because communication with the server (cloud) failed.</p> <p>Check the following contents depending on the status of indoor unit wireless LAN indicator lamp or WLAN Adapter LED 2 and operate again.</p> <ul style="list-style-type: none"> When not lighting <ul style="list-style-type: none"> Check that the Electrical panel (Switch breaker) to the air conditioner is turned on. Check that the power plug of the air conditioner main unit is plugged in. When lighting <p>Use a smartphone to check that the wireless router to which the air conditioner is connected is connected to the Internet. If the smartphone cannot connect to the Internet, reboot the wireless router. When rebooting the wireless router does not solve the problem, contact the manufacturer of the wireless router.</p> When blinking <p>Wait for a while until the lamp lights and then operate again. If the lamp is still blinking after waiting for a while, check that the wireless router is turned on.</p>

Error code	Error message	Cause
		Solution
1720	<p>Loading of error history failed. Check the following contents.</p> <ul style="list-style-type: none"> • Ensure that your mobile device is connected to the internet. 	<p>The error history information could not be obtained because communication with the server (cloud) failed.</p> <p>Check the following contents depending on the status of indoor unit wireless LAN indicator lamp or WLAN Adapter LED 2 and operate again.</p> <ul style="list-style-type: none"> • When not lighting <ul style="list-style-type: none"> – Check that the Electrical panel (Switch breaker) to the air conditioner is turned on. – Or check that the power plug of the air conditioner main unit is plugged in. • When lighting <p>Use a smartphone to check that the wireless router to which the air conditioner is connected is connected to the Internet. If the smartphone cannot connect to the Internet, reboot the wireless router. When rebooting the wireless router does not solve the problem, contact the manufacturer of the wireless router.</p> • When blinking <p>Wait for a while until the indicator lamp lights and then operate again. If the indicator lamp is still blinking after waiting for a while, check that the wireless router is turned on.</p>
3110	<p>Communication failure prevented the group movement processing from being conducted. After checking the following contents, please try again after a while.</p> <ul style="list-style-type: none"> • Ensure that your mobile device is connected to the internet. 	<p>Air conditioner group setting has not been completed because communication with air conditioner failed.</p> <p>Check the following contents depending on the status of indoor unit wireless LAN indicator lamp or WLAN Adapter LED 2 and operate again.</p> <ul style="list-style-type: none"> • When not lighting <ul style="list-style-type: none"> – Check that the Electrical panel (Switch breaker) to the air conditioner is turned on. – Check that the power plug of the air conditioner main unit is plugged in. • When lighting <p>Use a smartphone to check that the wireless router to which the air conditioner is connected is connected to the Internet. If the smartphone cannot connect to the Internet, reboot the wireless router. When rebooting the wireless router does not solve the problem, contact the manufacturer of the wireless router.</p> • When blinking <p>Wait for a while until the indicator lamp lights and then operate again. If the indicator lamp is still blinking after waiting for a while, check that the wireless router is turned on.</p>

Error code	Error message	Cause
		Solution
3111	<p>Communication failure prevented the group creation processing from being conducted. After checking the following contents, please try again after a while.</p> <ul style="list-style-type: none"> Ensure that your mobile device is connected to the internet. 	<p>Air conditioner group setting has not been completed because communication with air conditioner failed.</p> <p>Check the following contents depending on the status of indoor unit wireless LAN indicator lamp or WLAN Adapter LED 2 and operate again.</p> <ul style="list-style-type: none"> When not lighting <ul style="list-style-type: none"> Check that the Electrical panel (Switch breaker) to the air conditioner is turned on. Check that the power plug of the air conditioner main unit is plugged in. When lighting <p>Use a smartphone to check that the wireless router to which the air conditioner is connected is connected to the Internet. If the smartphone cannot connect to the Internet, reboot the wireless router. When rebooting the wireless router does not solve the problem, contact the manufacturer of the wireless router.</p> When blinking <p>Wait for a while until the indicator lamp lights and then operate again. If the indicator lamp is still blinking after waiting for a while, check that the wireless router is turned on.</p>
3112	<p>Communication failure prevented the group name change processing from being conducted. After checking the following contents, please try again after a while.</p> <ul style="list-style-type: none"> Ensure that your mobile device is connected to the internet. 	<p>Air conditioner group setting has not been completed because communication with air conditioner failed.</p> <p>Check the following contents depending on the status of indoor unit wireless LAN indicator lamp or WLAN Adapter LED 2 and operate again.</p> <ul style="list-style-type: none"> When not lighting <ul style="list-style-type: none"> Check that the Electrical panel (Switch breaker) to the air conditioner is turned on. Check that the power plug of the air conditioner main unit is plugged in. When lighting <p>Use a smartphone to check that the wireless router to which the air conditioner is connected is connected to the Internet. If the smartphone cannot connect to the Internet, reboot the wireless router. When rebooting the wireless router does not solve the problem, contact the manufacturer of the wireless router.</p> When blinking <p>Wait for a while until the indicator lamp lights and then operate again. If the indicator lamp is still blinking after waiting for a while, check that the wireless router is turned on.</p>

Error code	Error message	Cause
		Solution
3113	<p>Communication failure prevented the group deletion processing from being conducted. After checking the following contents, please try again after a while.</p> <ul style="list-style-type: none"> Ensure that your mobile device is connected to the internet. 	<p>Air conditioner group setting has not been completed because communication with air conditioner failed.</p> <p>Check the following contents depending on the status of indoor unit wireless LAN indicator lamp or WLAN Adapter LED 2 and operate again.</p> <ul style="list-style-type: none"> When not lighting <ul style="list-style-type: none"> Check that the Electrical panel (Switch breaker) to the air conditioner is turned on. Check that the power plug of the air conditioner main unit is plugged in. When lighting <p>Use a smartphone to check that the wireless router to which the air conditioner is connected is connected to the Internet. If the smartphone cannot connect to the Internet, reboot the wireless router. When rebooting the wireless router does not solve the problem, contact the manufacturer of the wireless router.</p> When blinking <p>Wait for a while until the indicator lamp lights and then operate again. If the indicator lamp is still blinking after waiting for a while, check that the wireless router is turned on.</p>
3114	<p>The room temperature display indoor unit setting could not be made due to a communication failure. After checking the following contents, please try again after a while.</p> <ul style="list-style-type: none"> Ensure that your mobile device is connected to the internet. 	<p>Air conditioner group setting has not been completed because communication with air conditioner failed.</p> <p>Check the following contents depending on the status of indoor unit wireless LAN indicator lamp or WLAN Adapter LED 2 and operate again.</p> <ul style="list-style-type: none"> When not lighting <ul style="list-style-type: none"> Check that the Electrical panel (Switch breaker) to the air conditioner is turned on. Check that the power plug of the air conditioner main unit is plugged in. When lighting <p>Use a smartphone to check that the wireless router to which the air conditioner is connected is connected to the Internet. If the smartphone cannot connect to the Internet, reboot the wireless router. When rebooting the wireless router does not solve the problem, contact the manufacturer of the wireless router.</p> When blinking <p>Wait for a while until the indicator lamp lights and then operate again. If the indicator lamp is still blinking after waiting for a while, check that the wireless router is turned on.</p>

Error code	Error message	Cause
		Solution
3115	Some device group move processing could not be conducted due to communication failure. After checking the following contents, please try again after a while. <ul style="list-style-type: none"> Ensure that your mobile device is connected to the internet. 	<p>Air conditioner group setting has not been completed because communication with air conditioner failed.</p> <p>Check the following contents depending on the status of indoor unit wireless LAN indicator lamp or WLAN Adapter LED 2 and operate again.</p> <ul style="list-style-type: none"> When not lighting <ul style="list-style-type: none"> Check that the Electrical panel (Switch breaker) to the air conditioner is turned on. Check that the power plug of the air conditioner main unit is plugged in. When lighting <p>Use a smartphone to check that the wireless router to which the air conditioner is connected is connected to the Internet. If the smartphone cannot connect to the Internet, reboot the wireless router. When rebooting the wireless router does not solve the problem, contact the manufacturer of the wireless router.</p> When blinking <p>Wait for a while until the indicator lamp lights and then operate again. If the indicator lamp is still blinking after waiting for a while, check that the wireless router is turned on.</p>
5320	Loading of air conditioner information failed. Check the following contents. <ul style="list-style-type: none"> Ensure that your mobile device is connected to the internet. 	<p>Air conditioner information could not be obtained because communication with server (cloud) failed.</p> <ol style="list-style-type: none"> Check that the wireless LAN setting of smartphone is set to ON. Check that the smartphone is connected to the Internet. Check that the wireless router is turned on.
5531 5540	New firmware update failed.	<p>Firmware update failed.</p> <p>Check the following contents and operate again.</p> <ol style="list-style-type: none"> Check that the wireless LAN setting of smartphone is set to ON. Check that the smartphone is connected to the Internet. Check that the wireless router is turned on. Refer to the operation manual of air conditioner and check the indicator lamp state of air conditioner indoor unit.
5601	Failed to get the air conditioner information.	<p>Failed to obtain air conditioner information by Direct Control.</p> <p>Sign in again.</p>
5602	Failed to add the air conditioner.	<p>Failed to add air conditioner by Direct Control.</p> <p>Check the following contents and operate again.</p> <ol style="list-style-type: none"> When 2D barcode label is used, scan 2D barcode label again. When 2D barcode label is not used, check that the entered SSID or PIN code is correct.
5630	Device disconnection failed. After checking the following contents, please try again after a while. <ul style="list-style-type: none"> Ensure that your mobile device is connected to the internet. 	<p>Failed to disconnect the connection with air conditioner by Direct Control.</p> <p>Check the following contents and operate again.</p> <ol style="list-style-type: none"> Check that the smartphone is connected with the air conditioner. Check that the Electrical panel (Switch breaker) to the air conditioner is turned on. Check that the power plug of the air conditioner main unit is plugged in.

Error code	Error message	Cause
		Solution
6201	Failed to update the screen. After checking the following contents, please try again after a while. <ul style="list-style-type: none"> Ensure that your mobile device is connected to the internet. 	Various settings could not be completed because communication with the server (cloud) failed.
		Check the following contents and operate again. <ol style="list-style-type: none"> Check that the wireless LAN setting of smartphone is set to ON. Check that the smartphone is connected to the Internet. Check that the wireless router is turned on.
7610	Communication failed. Check the following contents. <ul style="list-style-type: none"> Ensure that your mobile device is connected to the internet. 	Various settings could not be completed because communication with the server (cloud) failed.
		Check the following contents and operate again. <ol style="list-style-type: none"> Check that the wireless LAN setting of smartphone is set to ON. Check that the smartphone is connected to the Internet. Check that the wireless router is turned on.

2. Troubleshooting

NOTE: Some troubleshooting procedures mention non-equipped components, depending on the model. If the component described in the troubleshooting procedure is not present in the model, skip the procedure for that component.

2-1. Troubleshooting with error code

■ E: 11. Serial communication error (Serial forward transfer error)

A serial forward transfer error occurs when the outdoor unit cannot receive the serial signal from the indoor unit for more than 10 seconds.

INDICATOR

For a list of errors and associated error indicators, refer to "[Error codes and indicators](#)" on page 03-2.

POSSIBLE CAUSE

The following are possible causes of this error.

- Connection failure
- External cause
- Power supply failure
- Indoor unit fan motor failure
- Indoor unit Main PCB failure
- Outdoor unit Main PCB failure

TROUBLESHOOTING STEPS

1. Turn the power off and on again.

If the error indication still repeats, go to step 2. If not, go to step 3.

2. Check if any external cause exists.

If you find any of the following problems, correct them by referring to the *Installation Manual* or the *DESIGN & TECHNICAL MANUAL*.

- Close installation of neon light bulbs or other electronic equipment that generates harmonic waves near the power supply cable
- Cable miswiring or connector disconnections on the control unit of the indoor unit or the outdoor unit
- Grounding failure caused by an incomplete insulation

If none of these external cause exist, go to step 3.

3. Verify the power supply voltage.

Check if the outdoor unit's terminal block L—N voltage is in the available voltage range specified in the product specifications.

For the available voltage range, refer to "[Specifications](#)" in Chapter 1. GENERAL INFORMATION on page 01-1.



4. Verify the serial signal (forward transfer signal).

Check that indicated value swings between AC 30 V and AC 130 V at the outdoor unit's terminal block 2—3.

If the indicated value is in the range, go to step 5. If not, go to step 6.

5. Verify individual component failure.

Check whether the following components work appropriately by referring to "[Service parts information](#)" on page 03-76. If there is a failure, replace the component.

- Indoor unit fan motor
- Indoor unit Main PCB

If these parts replacements do not correct the symptom, go to step 6.

6. Replace the outdoor unit Main PCB.

If you find a short circuit or corrosion on the Main PCB or none of the previous steps correct the symptom, replace the outdoor unit Main PCB.

END

■ E: 12. Wired remote controller communication error

A wired remote controller communication error occurs when the indoor unit cannot receive the signal from the wired remote controller for a certain number of minutes. (For more than 1 minute for the 3-wire type and 2.5 minutes for the 2-wire type.)

INDICATOR

For a list of errors and associated error indicators, refer to "[Error codes and indicators](#)" on page 03-2.

POSSIBLE CAUSE

The following are possible causes of this error.

- Connection failure
- Remote controller group setting error
- Wired Remote Controller failure
- Indoor unit Main PCB failure
- Communication Kit* failure

*: Some models may not have this component or the module.

TROUBLESHOOTING STEPS

1. Verify the cable connection.

After turning off the power, check the connection of the terminal block between the indoor unit and the Wired Remote Controller. Some models may have the Communication Kit between the indoor unit and the Wired Remote Controller.

If you find a cable disconnection, reconnect the cable appropriately.

Turn the power on again. If the error indication still repeats, go to step 2.

2. Verify the remote controller group setting.

Make sure that there is no setting error such as the following:

- Wrong connection within the remote controller group
- The number of indoor units and remote controllers in one remote controller group exceeds 16 units.

If you find any of problems above, correct them by referring to the *Installation Manual*.

If there is no remote controller group setting error, go to step 3.

3. Verify the power supply voltage.

Check if the power supply voltage to the remote controller is correct.

- If the indicated value is the same as those shown in the PC board diagram, it suggests the remote controller failure.
Replace the Wired Remote Controller.
- If the indicated value is DC 0 V, it suggests the indoor unit Main PCB failure.
Go to step 4.



For the remote controller power supply terminal block location and the voltage, refer to "[PC board diagrams](#)" in Chapter 2. TECHNICAL DATA AND PARTS LIST on page 02-16.

4. Replace the indoor unit Main PCB.

If you find a short circuit or corrosion on the Main PCB or none of the previous steps correct the symptom, replace the indoor unit Main PCB.

NOTE: After replacing the Main PCB, set the remote controller address appropriately.

END

■ E: 15. Automatic airflow adjustment error

An automatic airflow adjustment error occurs when the fan speed is not appropriately controlled in the automatic airflow adjustment operation.

INDICATOR

For a list of errors and associated error indicators, refer to "[Error codes and indicators](#)" on page 03-2.

POSSIBLE CAUSE

The following are possible causes of this error.

- External cause
- Indoor unit fan rotation error
 - Indoor unit fan failure
 - Indoor unit fan motor failure
 - Bearing failure
- Indoor unit Main PCB failure

TROUBLESHOOTING STEPS

1. **Check if any external cause exists.**
Excessive heat around the fan motor may cause the motor to malfunction.
If any surrounding equipment causes heat, stop the operation and wait until the temperature around the motor cools down. After you make sure that the temperature comes down, restart the operation.
If the error indication still repeats, go to step 2.
2. **Verify the fan rotation.**
After turning off the power, rotate the fan by hand. If the fan is caught, dropped off, or has a locked motor, replace the following components.
 - Indoor unit fan
 - Bearing
 If these parts replacements do not correct the symptom, go to step 3.
3. **Replace the indoor unit fan motor.**
Check whether the indoor unit fan work appropriately by referring to "[Service parts information](#)" on page 03-76. If there is a failure, replace the component.
If this part replacement does not correct the symptom, go to step 4.
4. **Replace the indoor unit Main PCB.**
If you find a short circuit or corrosion on the Main PCB or none of the previous steps correct the symptom, replace the indoor unit Main PCB.

END

■ E: 18. External communication error

An external communication error occurs when the indoor unit does not receive the same signal from the External Input and Output PCB 15 seconds after the indoor unit last received a signal from the External Input and Output PCB.

INDICATOR

For a list of errors and associated error indicators, refer to "[Error codes and indicators](#)" on page 03-2.

POSSIBLE CAUSE

The following are possible causes of this error.

- Connection failure
- External Input and Output PCB failure
- WLAN Adapter failure
- Indoor unit Main PCB failure

TROUBLESHOOTING STEPS

1. Verify the cable connection.

After turning off the power, check the cable connection between the indoor unit and the following devices:

- External Input and Output PCB
- WLAN Adapter

If you find a cable disconnection, reconnect the cable appropriately.

Turn the power on again. If the error indication still repeats, go to step 2.

2. Verify individual component failure.

If the previous steps do not solve the problem, replace the following components.

- External Input and Output PCB
- WLAN Adapter

If these parts replacements do not correct the symptom, go to step 3.

3. Replace the indoor unit Main PCB.

If you find a short circuit or corrosion on the Main PCB or none of the previous steps correct the symptom, replace the indoor unit Main PCB.

END

■ E: 22. Indoor unit capacity error

An indoor unit capacity error occurs when the indoor unit(s)'s total capacity does not match the outdoor unit's capacity after 3 minutes of power-on.

INDICATOR

For a list of errors and associated error indicators, refer to "[Error codes and indicators](#)" on page 03-2.

POSSIBLE CAUSE

The following are possible causes of this error.

- Incorrect indoor unit selection
- Outdoor unit Main PCB failure

TROUBLESHOOTING STEPS

1. Check the total capacity of the indoor unit.

If you find any problems, correct them by referring to the *Installation Manual* or the *DESIGN & TECHNICAL MANUAL*.

If the total capacity of the indoor unit(s) is correct, go to step 2.

2. Replace the outdoor unit Main PCB.

If you find a short circuit or corrosion on the Main PCB or none of the previous steps correct the symptom, replace the outdoor unit Main PCB.

END

■ E: 23. Refrigerant combination error

A refrigerant combination error occurs when the outdoor unit receives a serial signal with different refrigerant type information from the indoor unit.

INDICATOR

For a list of errors and associated error indicators, refer to "[Error codes and indicators](#)" on page 03-2.

POSSIBLE CAUSE

The following are possible causes of this error.

- Incorrect indoor unit selection
- Outdoor unit Main PCB failure

TROUBLESHOOTING STEPS

- 1. Check if the refrigerant type of the outdoor unit and the indoor unit(s) match.**
If you find any problems, correct them by referring to the *Installation Manual* or the *DESIGN & TECHNICAL MANUAL*.
If the refrigerant type of the outdoor unit and the indoor unit(s) match, go to step 2.
- 2. Replace the outdoor unit Main PCB.**
If you find a short circuit or corrosion on the Main PCB or none of the previous steps correct the symptom, replace the outdoor unit Main PCB.

END

■ E: 26. Wired remote controller address setting error

A wired remote controller address setting error occurs when there is an inconsistency in the address number settings within one remote controller group.

INDICATOR

For a list of errors and associated error indicators, refer to "[Error codes and indicators](#)" on page 03-2.

POSSIBLE CAUSE

The following are possible causes of this error.

- Connection failure in a remote controller group
- Remote controller address setting error
- Wired Remote Controller failure
- Indoor unit Main PCB failure

TROUBLESHOOTING STEPS

1. **Verify the cable connection.**
Check if the cable connection in the remote controller group is correct.
If you find a problem, correct it by referring to the *Installation Manual*.
If there is no cable connection error, go to step 2.
2. **Verify the remote controller group setting.**
Make sure that there is no setting error such as the following:
 - Mixed use of the address number (00) assigned by automatic setting and the number (other than 00) assigned by manual setting in one remote controller group.
 - The address duplication within one remote controller group, such as the address set by UI.If you find any of problems above, correct them by referring to the *Installation Manual*.
If there is no remote controller group setting error, go to step 3.
3. **Replace the indoor unit Main PCB.**
If you find a short circuit or corrosion on the Main PCB or none of the previous steps correct the symptom, replace the indoor unit Main PCB.

NOTE: After replacing the Main PCB, set the remote controller address appropriately.

END

■ E: 29. Connected unit number error

A connected unit number error occurs when the number of indoor units connected within one remote controller group exceeds the limit.

INDICATOR

For a list of errors and associated error indicators, refer to "[Error codes and indicators](#)" on page 03-2.

POSSIBLE CAUSE

The following are possible causes of this error.

- Connection failure in a remote controller group
 - Wiring error of the indoor unit or the remote controller
 - The connectable unit number in one remote controller group exceeded
- Indoor unit Main PCB failure

TROUBLESHOOTING STEPS

1. **Check the connected unit(s) number in one remote controller group.**

Ensure the total unit numbers of the indoor unit(s) and the remote controller(s) in one remote controller group are less than 16 units.

If you find a problem, correct them by referring to the *Installation Manual*.

If there is no remote controller group setting error, go to step 2.
2. **Replace the indoor unit Main PCB.**

If you find a short circuit or corrosion on the Main PCB or none of the previous steps correct the symptom, replace the indoor unit Main PCB.

NOTE: After replacing the Main PCB, set the remote controller address appropriately.

END

■ E: 32. Indoor unit Main PCB error

An indoor unit Main PCB error occurs when the EEPROM* information of the indoor unit is not accessible or is incorrect.

*: Electronically Erasable and Programmable Read Only Memory.

A non-volatile memory that keeps memorized information even if you turn off the device. You can change the contents of EEPROM electronically. To change the contents, you use a higher voltage than usual. To rewrite, you must erase all contents so you cannot partially alter contents. You can only rewrite the contents of EEPROM a limited number of times.

INDICATOR

For a list of errors and associated error indicators, refer to ["Error codes and indicators"](#) on page 03-2.

POSSIBLE CAUSE

The following are possible causes of this error.

- External cause
- Connection failure
- Indoor unit Main PCB failure

TROUBLESHOOTING STEPS

1. Turn the power off and on again.

If the error indication still repeats, go to step 2.

2. Check if any external cause exists.

If you find any of the following problems, correct them by referring to the *Installation Manual* or the *DESIGN & TECHNICAL MANUAL*.

- Close installation of neon light bulbs or other electronic equipment that generates harmonic waves near the power supply cable
- Cable miswiring or connector disconnections on the control unit of the indoor unit or the outdoor unit
- Grounding failure caused by an incomplete insulation

If none of these external cause exist, go to step 3.

3. Replace the indoor unit Main PCB.

If you find a short circuit or corrosion on the Main PCB or none of the previous steps correct the symptom, replace the indoor unit Main PCB.

END

■ E: 33. Indoor unit motor electricity consumption detection error

An indoor unit motor electricity consumption detection error occurs when the voltage or the current value of the indoor unit fan motor exceeds the limit.

INDICATOR

For a list of errors and associated error indicators, refer to "[Error codes and indicators](#)" on page 03-2.

POSSIBLE CAUSE

The following are possible causes of this error.

- External cause
- Indoor unit fan rotation error
 - Indoor unit fan failure
 - Indoor unit fan motor failure
 - Bearing failure
- Indoor unit Main PCB failure

TROUBLESHOOTING STEPS

1. Check if any external cause exists.

Excessive heat around the fan motor may cause the motor to malfunction.

If any surrounding equipment causes heat, stop the operation and wait until the temperature around the motor cools down. After you make sure that the temperature comes down, restart the operation.

If the error indication still repeats, go to step 2.

2. Verify the fan rotation.

After turning off the power, rotate the fan by hand. If the fan is caught, dropped off, or has a locked motor, replace the following components.

- Indoor unit fan
- Bearing

If these parts replacements do not correct the symptom, go to step 3.

3. Replace the indoor unit fan motor.

Check whether the indoor unit fan work appropriately by referring to "[Service parts information](#)" on page 03-76. If there is a failure, replace the component.

If this part replacement does not correct the symptom, go to step 4.

4. Replace the indoor unit Main PCB.

If you find a short circuit or corrosion on the Main PCB or none of the previous steps correct the symptom, replace the indoor unit Main PCB.

END

■ E: 35. MANUAL AUTO button error

A MANUAL AUTO button error occurs when the MANUAL AUTO button is on continuously for over 60 seconds.

INDICATOR

For a list of errors and associated error indicators, refer to "[Error codes and indicators](#)" on page 03-2.

POSSIBLE CAUSE

The following are possible causes of this error.

- MANUAL AUTO button remains pressed
- MANUAL AUTO button failure
- Indoor unit Indicator PCB failure
- Indoor unit Main PCB failure

TROUBLESHOOTING STEPS

1. Check whether the MANUAL AUTO button works appropriately.

Check whether there are any of the following problems.

- The MANUAL AUTO button remains pressed.
- The on/off switching does not work. To verify whether the switching operation works properly, use a resistance meter.



If you find any of problems above, replace the MANUAL AUTO button.

If this part replacement does not correct the symptom, go to step 2.

2. Replace the indoor unit Indicator PCB.

If you find a short circuit or corrosion on the Indicator PCB or none of the previous steps correct the symptom, replace the indoor unit Indicator PCB.

If this part replacement does not correct the symptom, go to step 3.

3. Replace the indoor unit Main PCB.

If you find a short circuit or corrosion on the Main PCB or none of the previous steps correct the symptom, replace the indoor unit Main PCB.

END

■ E: 39. Power supply error of indoor unit fan motor

A power supply error of indoor unit fan motor occurs when the fan motor does not receive the necessary voltage values to operate.

INDICATOR

For a list of errors and associated error indicators, refer to "[Error codes and indicators](#)" on page 03-2.

POSSIBLE CAUSE

The following are possible causes of this error.

- Voltage drop
- External cause
- Connection failure
- Indoor unit Main PCB failure

TROUBLESHOOTING STEPS

- 1. Check if a voltage drop occurs in the same electrical circuit.**

Large electrical loads in the same circuit may cause a voltage drop and cause insufficient voltage supply to the indoor unit fan motor. Redesign the circuit if any apparatus causes large electrical loads.

If no large electrical loads exist in the same circuit, go to step 2.
- 2. Check if any external cause exists.**

If you find any of the following problems, correct them by referring to the *Installation Manual* or the *DESIGN & TECHNICAL MANUAL*.

 - Close installation of neon light bulbs or other electronic equipment that generates harmonic waves near the power supply cable
 - Cable miswiring or connector disconnections on the control unit of the indoor unit or the outdoor unit
 - Grounding failure caused by an incomplete insulation

If none of these external cause exist, go to step 3.
- 3. Replace the indoor unit Main PCB.**

If you find a short circuit or corrosion on the Main PCB or none of the previous steps correct the symptom, replace the indoor unit Main PCB.

END

■ E: 3A. Indoor unit communication circuit error

An indoor unit communication circuit error occurs when the Main PCB cannot communicate with the parts to be connected.

INDICATOR

For a list of errors and associated error indicators, refer to "[Error codes and indicators](#)" on page 03-2.

POSSIBLE CAUSE



The following are possible causes of this error.

- Connection failure
- Indoor unit Communication PCB failure
- Wired Remote Controller failure
- Indoor unit Main PCB failure

TROUBLESHOOTING STEPS

PREREQUISITE:

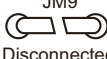
The settings of the components on the indoor unit Main PCB depend on the parts connected to the PCB. Before starting this troubleshooting, check whether the settings of components on the Main PCB are correct.

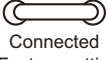

Connected parts to the Main PCB		Components setting on the Main PCB	
Wired Remote Controller	Communication PCB	DIP switch	Jumper (JM9)
2-wire type	Not connected	 2WIRE/3WIRE Factory setting: 2WIRE	 JM9 Disconnected
3-wire type	Not connected	 2WIRE/3WIRE Factory setting: 3WIRE	 JM9 Connected (Factory setting)

If the settings of components on the Main PCB are not correct, the following symptoms appear.

- Each device indicates the error 3A.

Connected parts to the Main PCB		Components setting on the Main PCB	
Wired Remote Controller	Communication PCB	DIP switch	Jumper (JM9)
2-wire type	Not connected	—	 JM9 Disconnected

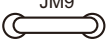
- Wired Remote Controller does not work.

Connected parts to the Main PCB		Components setting on the Main PCB	
Wired Remote Controller	Communication PCB	DIP switch	Jumper (JM9)
2-wire type	Connected	—	 JM9 Connected (Factory setting)
	Not connected	 2WIRE/3WIRE Factory setting: 3WIRE	—
3-wire type	Not connected	 2WIRE/3WIRE Factory setting: 2WIRE	—

1. Verify the cable connection.

After turning off the power, check the connection of the terminal block between the indoor unit and the Wired Remote Controller. Some models may have the Communication Kit between the indoor unit and the Wired Remote Controller.

If you find a cable disconnection, reconnect the cable appropriately.

Turn the power on again. If the error indication still repeats, go to step 2.

2. Replace the Communication PCB.

If you find a short circuit or corrosion on the Communication PCB or none of the previous steps correct the symptom, replace the indoor unit Communication PCB.

Turn the power on again. If the error indication still repeats, go to step 3.

3. Verify the power supply voltage.

Check if the power supply voltage to the remote controller is correct.

- If the indicated value is the same as those shown in the PC board diagram, it suggests the remote controller failure.
Replace the Wired Remote Controller.
- If the indicated value is DC 0 V, it suggests the indoor unit Main PCB failure.
Go to step 4.



For the remote controller power supply terminal block location and the voltage, refer to "[PC board diagrams](#)" in Chapter 2. TECHNICAL DATA AND PARTS LIST on page 02-16.

4. Replace the indoor unit Main PCB.

If you find a short circuit or corrosion on the Main PCB or none of the previous steps correct the symptom, replace the indoor unit Main PCB.

NOTE: After replacing the Main PCB, set the remote controller address appropriately.

END

■ E: 41 / 42. Indoor unit thermistor error

An indoor unit thermistor error occurs when the indoor unit detects that the following thermistor is open or short-circuited.

- Room temperature thermistor (E: 41)
- Heat exchanger temperature thermistor (E: 42)

INDICATOR

For a list of errors and associated error indicators, refer to ["Error codes and indicators"](#) on page 03-2.

POSSIBLE CAUSE

The following are possible causes of this error.

- Connection failure
- External cause
- Thermistor failure
- Indoor unit Main PCB failure

TROUBLESHOOTING STEPS

1. Verify the cable connection.

After turning off the power, check the connection of the terminal between the indoor unit and the thermistor.

If you find a cable disconnection, reconnect the cable appropriately.

Turn the power on again. If the error indication still repeats, go to step 2.

2. Verify the thermistor failure.

Check whether the thermistor works appropriately by referring to ["Thermistor resistance values"](#) on page 03-84. For the thermistor terminal location, refer to ["PC board diagrams"](#) in Chapter 2. TECHNICAL DATA AND PARTS LIST on page 02-16.

If there is a failure, replace the component.

If this part replacement does not correct the symptom, go to step 3.



3. Verify the power supply voltage.

Check if the power supply voltage to the thermistor is correct.

- If the indicated value is the same as those shown in the PC board diagram, it suggests the thermistor failure. Replace the thermistor.
- If the indicated value is DC 0 V, it suggests the indoor unit Main PCB failure. Go to step 4.



For the thermistor terminal location and the voltage, refer to ["PC board diagrams"](#) in Chapter 2. TECHNICAL DATA AND PARTS LIST on page 02-16.

4. Replace the indoor unit Main PCB.

If you find a short circuit or corrosion on the Main PCB or none of the previous steps correct the symptom, replace the indoor unit Main PCB.

END

■ E: 44. Human sensor error

A human sensor error occurs when the indoor unit cannot receive the signal from the human sensor.

INDICATOR

For a list of errors and associated error indicators, refer to "[Error codes and indicators](#)" on page 03-2.

POSSIBLE CAUSE

The following are possible causes of this error.

- Connection failure
- Human sensor failure
- Indoor unit Main PCB failure

TROUBLESHOOTING STEPS

1. Verify the cable connection.

After turning off the power, check the connection of the terminal between the indoor unit and the human sensor.

If you find a cable disconnection, reconnect the cable appropriately.

Turn the power on again. If the error indication still repeats, go to step 2.

2. Verify the power supply voltage.

Check if the power supply terminal voltage to the 2 to 3 pin of the human sensor is 5 V. For the terminal location, refer to "[PC board diagrams](#)" in Chapter 2. TECHNICAL DATA AND PARTS LIST on page 02-16.

If the indicated value is not 5 V, it suggests the indoor unit Main PCB failure. Go to step 5.

If there is no failure, go to step 3.

3. Verify the conduction.

After turning off the power, check if the 4 to 5 pin of the terminal for the indoor unit Main PCB connecting to the human sensor is with conduction. For the terminal location, refer to "[PC board diagrams](#)" in Chapter 2. TECHNICAL DATA AND PARTS LIST on page 02-16.

NOTE: Connect the wire with connector to the terminal for the indoor unit Main PCB connecting to the sensor when checking the conduction.

If the 4 to 5 pin is without conduction, replace the wire with connector.

If this part replacement does not correct the symptom, there is no failure, or the wire with the connector does not have 5 pins, go to step 4.

4. Replace the sensor.

If none of the previous steps correct the symptom, replace the sensor.

If this part replacement does not correct the symptom, go to step 5.

5. Replace the indoor unit Main PCB.

If you find a short circuit or corrosion on the Main PCB or none of the previous steps correct the symptom, replace the indoor unit Main PCB.

END

■ E: 51. Indoor unit fan motor error

An indoor unit fan motor error occurs when the rotation number does not reach the target number after 56 seconds have passed since the fan motor started the rotation.

INDICATOR

For a list of errors and associated error indicators, refer to "[Error codes and indicators](#)" on page 03-2.

POSSIBLE CAUSE

The following are possible causes of this error.

- External cause
- Indoor unit fan rotation error
 - Indoor unit fan failure
 - Indoor unit fan motor failure
 - Bearing failure
- Capacitor* failure
- Power supply PCB* failure
- Indoor unit Main PCB failure

*: Some models may not have this component or the module.

TROUBLESHOOTING STEPS

1. Verify the fan rotation.

After turning off the power, rotate the fan by hand. If the fan is caught, dropped off, or has a locked motor, replace the following components.

- Indoor unit fan
- Bearing

If these parts replacements do not correct the symptom, go to step 2.

2. Check if any external cause exists.

Excessive heat around the fan motor may cause the motor to malfunction.

If any surrounding equipment causes heat, stop the operation and wait until the temperature around the motor cools down. After you make sure that the temperature comes down, restart the operation.

If the error indication still repeats, go to step 3.

3. Replace the indoor unit fan motor.

Check whether the indoor unit fan work appropriately by referring to "[Service parts information](#)" on page 03-76. If there is a failure, replace the component.

If this part replacement does not correct the symptom, go to step 4.

4. Verify the capacitor failure (if any).

Check whether the capacitor work appropriately by using a resistance meter. If there is a failure, replace the component.

If this part replacement does not correct the symptom, go to step 5.



5. Replace the Power supply PCB (if any).

If you find a short circuit or corrosion on the Power supply PCB or none of the previous steps correct the symptom, replace the Power supply PCB.

If this part replacement does not correct the symptom, go to step 6.

6. Replace the indoor unit Main PCB.

If you find a short circuit or corrosion on the Main PCB or none of the previous steps correct the symptom, replace the indoor unit Main PCB.

END

■ E: 62. Outdoor unit Main PCB communication error

An outdoor unit Main PCB communication error occurs when the EEPROM* information of the outdoor unit is not accessible or is incorrect.

*: Electronically Erasable and Programmable Read Only Memory.

A non-volatile memory that keeps memorized information even if you turn off the device. You can change the contents of EEPROM electronically. To change the contents, you use a higher voltage than usual. To rewrite, you must erase all contents so you cannot partially alter contents. You can only rewrite the contents of EEPROM a limited number of times.

INDICATOR

For a list of errors and associated error indicators, refer to ["Error codes and indicators"](#) on page 03-2.

POSSIBLE CAUSE

The following are possible causes of this error.

- External cause
- Connection failure
- Outdoor unit Main PCB failure

TROUBLESHOOTING STEPS

1. Turn the power off and on again.

If the error indication still repeats, go to step 3. If not, go to step 2.

2. Check if any external cause exists.

If you find any of the following problems, correct them by referring to the *Installation Manual* or the *DESIGN & TECHNICAL MANUAL*.

- Close installation of neon light bulbs or other electronic equipment that generates harmonic waves near the power supply cable
- Cable miswiring or connector disconnections on the control unit of the indoor unit or the outdoor unit
- Grounding failure caused by an incomplete insulation

If none of these external cause exist, go to step 3.

3. Verify the cable connection.

After turning off the power, check all the terminal connections for the indoor unit. If you find a cable disconnection, reconnect the cable appropriately.

Turn the power on again. If the error indication still repeats, go to step 4.

4. Replace the outdoor unit Main PCB.

If you find a short circuit or corrosion on the Main PCB or none of the previous steps correct the symptom, replace the outdoor unit Main PCB.

END

■ E: 63. Inverter error

An inverter error occurs when the outdoor unit receives error information from the Inverter PCB.

INDICATOR

For a list of errors and associated error indicators, refer to "[Error codes and indicators](#)" on page 03-2.

POSSIBLE CAUSE

The following are possible causes of this error.

- External cause
- Connection failure
- Inverter PCB failure
- Outdoor unit Main PCB failure

TROUBLESHOOTING STEPS

1. **Turn the power off and on again.**
If the error indication still repeats, go to step 3. If not, go to step 2.
2. **Check if any external cause exists.**
If you find any of the following problems, correct them by referring to the *Installation Manual* or the *DESIGN & TECHNICAL MANUAL*.
 - Close installation of neon light bulbs or other electronic equipment that generates harmonic waves near the power supply cable
 - Cable miswiring or connector disconnections on the control unit of the indoor unit or the outdoor unit
 - Grounding failure caused by an incomplete insulation
 If none of these external cause exist, go to step 3.
3. **Verify the cable connection.**
After turning off the power, check the cable connection between the outdoor unit Main PCB and following devices:
 - Power supply
 - Inverter PCB
 If you find a cable disconnection, reconnect the cable appropriately.
Turn the power on again. If the error indication still repeats, go to step 4.
4. **Replace the Inverter PCB.**
If you find a short circuit or corrosion on the Inverter PCB or none of the previous steps correct the symptom, replace the Inverter PCB.
Turn the power on again. If the error indication still repeats, go to step 5.
5. **Replace the outdoor unit Main PCB.**
If you find a short circuit or corrosion on the Main PCB or none of the previous steps correct the symptom, replace the outdoor unit Main PCB.

END

■ E: 64. PFC circuit error

A PFC circuit error occurs when the voltage value of the inverter input DC exceeds the limit.

INDICATOR

For a list of errors and associated error indicators, refer to "[Error codes and indicators](#)" on page 03-2.

POSSIBLE CAUSE

The following are possible causes of this error.

- External cause
- Connection failure
- Active filter module failure
- Outdoor unit Main PCB failure

TROUBLESHOOTING STEPS

1. **Check if a voltage drop occurs in the same electrical circuit.**
Large electrical loads in the same circuit may cause overvoltage and cause damage to the converter. Redesign the circuit if any apparatus causes large electrical loads.
If no large electrical loads exist in the same circuit, go to step 2.
2. **Check if any external cause exists.**
If you find any of the following problems, correct them by referring to the *Installation Manual* or the *DESIGN & TECHNICAL MANUAL*.
 - Close installation of neon light bulbs or other electronic equipment that generates harmonic waves near the power supply cable
 - Cable miswiring or connector disconnections on the control unit of the outdoor unit or the outdoor unit
 - Grounding failure caused by an incomplete insulation
 If none of these external cause exist, go to step 3.
3. **Verify individual component failure.**
Check whether the following components work appropriately by referring to "[Service parts information](#)" on page 03-76. If there is a failure, replace the component.
 - Active filter module (if any)
 If these parts replacements do not correct the symptom, go to step 4.
4. **Replace the outdoor unit Main PCB.**
If you find a short circuit or corrosion on the Main PCB or none of the previous steps correct the symptom, replace the outdoor unit Main PCB.

END

■ E: 65. IPM error

An IPM error occurs when an overcurrent flows to the IPM.

INDICATOR

For a list of errors and associated error indicators, refer to ["Error codes and indicators"](#) on page 03-2.

POSSIBLE CAUSE

The following are possible causes of this error.

- External cause
- Connection failure
- Outdoor unit fan motor failure
- Compressor failure
- Inverter PCB* failure
- Outdoor unit Main PCB failure

*: Some models may not have these components or the modules.

TROUBLESHOOTING STEPS

1. Verify the cable connection.

After turning off the power, check all the terminal connections for the outdoor unit. If you find a cable disconnection, reconnect the cable appropriately.

Turn the power on again. If the error indication still repeats, go to step 2.

2. Check if any external cause exists.

If you find any of the following problems, remove the possible factors.

- Obstruction is in the air distribution circuit.
- The outdoor heat exchanger is clogged by dust or debris.
- There is excessive heat around the fan motor.

If none of these external cause exist or removing these factor does not correct the symptom, go to step 3.

3. Verify the fan rotation.

After turning off the power, rotate the fan by hand.

If the fan is caught, dropped off, or has a locked motor, replace the outdoor unit fan motor.

If this part replacement does not correct the symptom, go to step 4.

4. Verify the fan motor failure.

Check whether the fan motor work appropriately by referring ["Service parts information"](#) on page 03-76.

If there is a failure, replace the component.

If this part replacement does not correct the symptom, go to step 5.

5. Verify the compressor failure.

Check whether the compressor work appropriately by referring ["Service parts information"](#) on page 03-76.

If there is a failure, replace the component.

If this part replacement does not correct the symptom, go to step 6.

6. Replace the Inverter PCB.

If you find a short circuit or corrosion on the Inverter PCB or none of the previous steps correct the symptom, replace the Inverter PCB.

Turn the power on again. If the error indication still repeats, go to step 7.

7. Replace the outdoor unit Main PCB.

If you find a short circuit or corrosion on the Main PCB or none of the previous steps correct the symptom, replace the outdoor unit Main PCB.

END

■ E: 71 / 72 / 73 / 74 / 76 / 77. Outdoor unit thermistor error

An outdoor unit thermistor error occurs when the outdoor unit detects that the following thermistor is open or short.

- E: 71. Thermistor (Discharge temperature) error
- E: 72. Thermistor (Compressor temperature) error
- E: 73. Thermistor (Heat exchanger Middle/Outlet temperature) error
- E: 74. Thermistor (Outdoor temperature) error
- E: 76. Thermistor (2-way/3-way valve temperature) error
- E: 77. Thermistor (Heat sink temperature) error

INDICATOR

For a list of errors and associated error indicators, refer to ["Error codes and indicators"](#) on page 03-2.

POSSIBLE CAUSE

The following are possible causes of this error.

- Connection failure
- External cause
- Thermistor failure
- Inverter PCB* failure
- Outdoor unit Main PCB failure

*: Some models may not have these components or the modules.

TROUBLESHOOTING STEPS

1. Verify the cable connection.

After turning off the power, check the connection of the terminal between the outdoor unit and the thermistor.

If you find a cable disconnection, reconnect the cable appropriately.

Turn the power on again. If the error indication still repeats, go to step 2.

2. Verify the thermistor failure.

Check whether the thermistor works appropriately by referring to ["Thermistor resistance values"](#) on page 03-84. For the thermistor terminal location, refer to ["PC board diagrams"](#) in Chapter 2. TECHNICAL DATA AND PARTS LIST on page 02-16.



If there is a failure, replace the component.

If this part replacement does not correct the symptom, go to step 3.

3. Verify the power supply voltage.

Check if the power supply voltage to the thermistor is correct.

- If the indicated value is the same as those shown in the PC board diagram, it suggests the thermistor failure. Replace the thermistor.
- If the indicated value is DC 0 V, it suggests the outdoor unit Main PCB failure. Go to step 4.



For the thermistor terminal location and the voltage, refer to ["PC board diagrams"](#) in Chapter 2. TECHNICAL DATA AND PARTS LIST on page 02-16.

4. Replace the Inverter PCB. (if any)

If you find a short circuit or corrosion on the Inverter PCB or none of the previous steps correct the symptom, replace the Inverter PCB.

Turn the power on again. If the error indication still repeats, go to step 5.

5. Replace the outdoor unit Main PCB.

If you find a short circuit or corrosion on the Main PCB or none of the previous steps correct the symptom, replace the Outdoor unit Main PCB.

END

■ E: 84. Current sensor error

A current sensor error occurs when the input current sensor detects a current value lower than a certain value after the compressor starts operation.

INDICATOR

For a list of errors and associated error indicators, refer to "[Error codes and indicators](#)" on page 03-2.

POSSIBLE CAUSE

The following are possible causes of this error.

- External cause
- Connection failure
- Inverter PCB* failure
- Outdoor unit Main PCB failure

*: Some models may not have these components or the modules.

TROUBLESHOOTING STEPS

1. Turn the power off and on again.

If the error indication still repeats, go to step 3. If not, go to step 2.

2. Check if a voltage drop occurs in the same electrical circuit.

Large electrical loads in the same circuit may cause a voltage drop and cause insufficient voltage supply to the indoor unit and outdoor unit. Redesign the circuit if any apparatus causes large electrical loads.

If no large electrical loads exist in the same circuit, go to step 3.

3. Check if any external cause exists.

If you find any of the following problems, correct them by referring to the *Installation Manual* or the *DESIGN & TECHNICAL MANUAL*.

- Close installation of neon light bulbs or other electronic equipment that generates harmonic waves near the power supply cable
- Cable miswiring or connector disconnections on the control unit of the indoor unit or the outdoor unit
- Grounding failure caused by an incomplete insulation

If none of these external cause exist, go to step 4.

4. Verify the cable connection.

After turning off the power, check all the terminal connections for the outdoor unit. If you find a cable disconnection, reconnect the cable appropriately.

Turn the power on again. If the error indication still repeats, go to step 5.

5. Replace the Inverter PCB. (if any)

If you find a short circuit or corrosion on the Inverter PCB or none of the previous steps correct the symptom, replace the Inverter PCB.

Turn the power on again. If the error indication still repeats, go to step 6.

6. Replace the outdoor unit Main PCB.

If you find a short circuit or corrosion on the Main PCB or none of the previous steps correct the symptom, replace the outdoor unit Main PCB.

END

■ E: 94. Trip detection

A trip detection occurs when multiple consecutive protection stops due to overcurrent occurring after the inverter compressor completes the startup process.

INDICATOR

For a list of errors and associated error indicators, refer to ["Error codes and indicators"](#) on page 03-2.

POSSIBLE CAUSE

The following are possible causes of this error.

- External cause
- Connection failure
- Outdoor unit fan motor failure
- Compressor failure
- Inverter PCB* failure
- Outdoor unit Main PCB failure

*: Some models may not have these components or the modules.

TROUBLESHOOTING STEPS

1. Verify the cable connection.

After turning off the power, check all the terminal connections for the outdoor unit. If you find a cable disconnection, reconnect the cable appropriately.

Turn the power on again. If the error indication still repeats, go to step 2.

2. Check if any external cause exists.

If you find any of the following problems, remove the possible factors.

- Obstruction is in the air distribution circuit.
- The outdoor heat exchanger is clogged by dust or debris.
- There is excessive heat around the fan motor.

If none of these external cause exist or removing these factor does not correct the symptom, go to step 3.

3. Verify the fan rotation.

After turning off the power, rotate the fan by hand.

If the fan is caught, dropped off, or has a locked motor, replace the outdoor unit fan motor.

If this part replacement does not correct the symptom, go to step 4.

4. Verify the fan motor failure.

Check whether the fan motor work appropriately by referring ["Service parts information"](#) on page 03-76.

If there is a failure, replace the component.

If this part replacement does not correct the symptom, go to step 5.

5. Verify the compressor failure.

Check whether the compressor work appropriately by referring ["Service parts information"](#) on page 03-76.

If there is a failure, replace the component.

If this part replacement does not correct the symptom, go to step 6.

6. Replace the Inverter PCB.

If you find a short circuit or corrosion on the Inverter PCB or none of the previous steps correct the symptom, replace the Inverter PCB.

Turn the power on again. If the error indication still repeats, go to step 7.

7. Replace the outdoor unit Main PCB.

If you find a short circuit or corrosion on the Main PCB or none of the previous steps correct the symptom, replace the outdoor unit Main PCB.

END

■ E: 95. Compressor motor control error

A compressor motor control error occurs when the compressor cannot start after several restarts.

INDICATOR

For a list of errors and associated error indicators, refer to ["Error codes and indicators"](#) on page 03-2.

POSSIBLE CAUSE

The following are possible causes of this error.

- Connection failure
- Compressor failure
- Inverter PCB* failure
- Outdoor unit Main PCB failure

*: Some models may not have these components or the modules.

TROUBLESHOOTING STEPS

- 1. Check the compressor operation noise.**
If you hear abnormal noise from the compressor after turning on the power, stop the operation immediately and replace the compressor.
If this part replacement does not correct the symptom, go to step 2.
- 2. Verify the cable connection.**
After turning off the power, check the connection of the terminal between the compressor and the power supply. If you find a cable disconnection, reconnect the cable appropriately.
For the compressor connector location and resistance value, refer to ["Service parts information"](#) on page 03-76.
Turn the power on again. If the error indication still repeats, go to step 3.
- 3. Replace the Inverter PCB. (if any)**
If you find a short circuit or corrosion on the Inverter PCB or none of the previous steps correct the symptom, replace the Inverter PCB.
Turn the power on again. If the error indication still repeats, go to step 4.
- 4. Replace the outdoor unit Main PCB.**
If you find a short circuit or corrosion on the Main PCB or none of the previous steps correct the symptom, replace the outdoor unit Main PCB.

END

■ E: 97 / 98. Outdoor unit fan motor error

An outdoor unit fan motor error occurs when the rotation number of the outdoor unit fan motor does not reach 100 rpm after repeated restarts.

- Outdoor unit fan motor 1 (E: 97)
- Outdoor unit fan motor 2 (E: 98)

INDICATOR

For a list of errors and associated error indicators, refer to ["Error codes and indicators"](#) on page 03-2.

POSSIBLE CAUSE

The following are possible causes of this error.

- External cause
- Outdoor unit fan rotation error
 - Outdoor unit fan failure
 - Outdoor unit fan motor failure
 - Bearing failure
- Inverter PCB* failure
- Outdoor unit Main PCB failure

*: Some models may not have this component or the module.

TROUBLESHOOTING STEPS

1. Verify the fan rotation.

After turning off the power, rotate the fan by hand.

If the fan is caught, dropped off, or has a locked motor, replace the outdoor unit fan motor.

If this part replacement does not correct the symptom, go to step 2.

2. Check if any external cause exists.

Excessive heat around the fan motor may cause the motor to malfunction.

If any surrounding equipment causes heat, stop the operation and wait until the temperature around the motor cools down. After you make sure that the temperature comes down, restart the operation.

If the error indication still repeats, go to step 3.

3. Replace the outdoor unit fan motor.

Check whether the outdoor unit fan work appropriately by referring to ["Service parts information"](#) on page 03-76. If there is a failure, replace the component.

If this part replacement does not correct the symptom, go to step 4.

4. Verify the power supply voltage.

If the indicated value is not the same as those shown in the PC board diagram, it suggests the connected PCB failure. Replace the Inverter PCB (if any).

If there is no Inverter PCB or this part replacement does not correct the symptom, go to step 5.



For the outdoor unit fan motor power supply terminal location and the voltage, refer to ["PC board diagrams"](#) in Chapter 2. TECHNICAL DATA AND PARTS LIST on page 02-16.

5. Replace the outdoor unit Main PCB.

If you find a short circuit or corrosion on the Main PCB or none of the previous steps correct the symptom, replace the outdoor unit Main PCB.

END

TROUBLESHOOTING

TROUBLESHOOTING

■ E: 99. 4-way valve error

A 4-way valve error occurs when the temperature difference between the indoor unit heat exchanger and the room temperature is 10 degrees or more.

INDICATOR

For a list of errors and associated error indicators, refer to "[Error codes and indicators](#)" on page 03-2.

POSSIBLE CAUSE

The following are possible causes of this error.

- External cause
- Connection failure
- Thermistor failure
- Solenoid coil failure
- 4-way valve failure
- Outdoor unit Main PCB failure

TROUBLESHOOTING STEPS

1. Check if the air filter is clogged.

Remove any dust or debris that may be clogged in the air filter.

If the error indication still repeats, go to step 2.

2. Verify the cable connection.

After turning off the power, check all the terminal connections for the indoor unit. If you find a cable disconnection, reconnect the cable appropriately.

Turn the power on again. If the error indication still repeats, go to step 3.

3. Verify the thermistor failure.

Check whether the thermistor works appropriately by referring to "[Thermistor resistance values](#)" on page 03-84. For the thermistor terminal location, refer to "[PC board diagrams](#)" in Chapter 2. TECHNICAL DATA AND PARTS LIST on page 02-16.

If there is a failure, replace the component.

If this part replacement does not correct the symptom, go to step 4.



4. Verify individual component failure.

Check whether the following components work appropriately by referring to "[Service parts information](#)" on page 03-76. If there is a failure, replace the component.

- Solenoid coil
- 4-way valve

If these parts replacements do not correct the symptom, go to step 5.

5. Verify the compressor failure.

Check whether the compressor work appropriately by referring "[Service parts information](#)" on page 03-76.

If there is a failure, replace the component.

If this part replacement does not correct the symptom, go to step 6.

6. Verify the power supply voltage.

Check if the power supply voltage to the 4-way valve is in the available voltage range specified in the product specifications.

For the available voltage range, refer to "[Specifications](#)" in Chapter 1. GENERAL INFORMATION on page 01-1.

Replace the outdoor unit Main PCB if the following measurement value is indicated during each operation mode.

- Cooling operation: Within the available voltage range.
- Heating operation: Out of the available voltage range.

**7. Replace the outdoor unit Main PCB.**

If you find a short circuit or corrosion on the Main PCB or none of the previous steps correct the symptom, replace the outdoor unit Main PCB.

END

■ E: A1. Discharge temperature error

A discharge temperature error occurs when the compressor repeatedly stops by the discharge gas temperature over-rise prevention.

For details on the over-rise prevention control of the discharge gas temperature, refer to "[Various protections](#)" in Chapter 4. CONTROL AND FUNCTIONS on page 04-38

INDICATOR

For a list of errors and associated error indicators, refer to "[Error codes and indicators](#)" on page 03-2.

POSSIBLE CAUSE

The following are possible causes of this error.

- External cause
- 2-way valve* is shut off
- 3-way valve is shut off
- Electronic expansion valve* failure
- Capillary tube* failure
- Strainer* failure
- Outdoor unit fan motor failure
- Thermistor (Discharge temperature) failure
- Refrigerant charge shortage
- Refrigerant leakage
- Outdoor unit Main PCB failure

*: Some models may not have this component or the module.

TROUBLESHOOTING STEPS

1. **Verify the open/close status of the 2-way valve or 3-way valve.**
The valve to check differs depending on the operation mode.
 - In cooling operation, check the valve connecting to the gas pipe.
 - In heating operation, check the valve connecting to the liquid pipe.
 If you find the valve shutoff, open the valve.
If the error indication still repeats, go to step 2.
2. **Verify individual component failure.**
Check whether the following components work appropriately by referring to "[Service parts information](#)" on page 03-76. If there is a failure, replace the component.
 - Electronic expansion valve (if any)
 - Capillary tube (if any)
 If these parts replacements do not correct the symptom, go to step 3.
3. **Check the individual component for dust or debris.**
Check if the following components are clogged with dust. If you find clogging, remove the dust from component.
 - Strainer
 - Outdoor heat exchanger
 If the error indication still repeats, go to step 4.

4. Verify the fan rotation.

After turning off the power, rotate the fan by hand.

If the fan is caught, dropped off, or has a locked motor, replace the outdoor unit fan motor.

If this part replacement does not correct the symptom, go to step 5.

5. Verify the fan motor failure.

Check whether the fan motor work appropriately by referring "[Service parts information](#)" on page 03-76.

If there is a failure, replace the component.

If this part replacement does not correct the symptom, go to step 6.

6. Verify the thermistor failure.

Check whether the thermistor works appropriately by referring to "[Thermistor resistance values](#)" on page 03-84. For the thermistor terminal location, refer to "[PC board diagrams](#)" in Chapter 2. TECHNICAL DATA AND PARTS LIST on page 02-16.



If there is a failure, replace the component.

If this part replacement does not correct the symptom, go to step 7.

7. Check if the refrigerant leak occurs.

Check if refrigerant leakage occurs with your leak detector. If there is a leakage, repair the refrigerant leak.

If refrigerant does not leak or this repair does not correct the symptom, go to step 8.

8. Replace the outdoor unit Main PCB.

If you find a short circuit or corrosion on the Main PCB or none of the previous steps correct the symptom, replace the outdoor unit Main PCB.

END

2-2. Troubleshooting without error code

■ Indoor unit—No power

Forecast of cause	Power supply failure
	External cause
	Electrical components defective

Check point 1. Check installation condition

- Isn't the breaker down?
- Check loose or removed connection cable.

-> If abnormal condition is found, correct it by referring to the installation manual or the *DESIGN & TECHNICAL MANUAL*.



Check point 2. Check external cause at indoor and outdoor (voltage drop or noise)

- Instant drop: Check if there is a large load electric apparatus in the same circuit.
- Momentary power failure: Check if there is a defective contact or leak current in the power supply circuit.
- Noise: Check if there is any equipment causing harmonic wave near electric line. (Neon bulb or electric equipment that may cause harmonic wave)
Check the complete insulation of grounding.



Check point 3. Check electrical components

Check the voltage of power supply.

Check if AC 207 to 253 V appears at outdoor unit terminal L—N.

-> If no, go to "[Check point 1](#)" and "[Check point 2](#)".

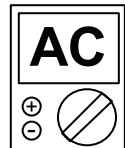

- Check fuse in the Filter PCB.
If fuse is open, check if the wiring between terminal and filter PCB is loose, and replace the Filter PCB.
- Check varistor in the Filter PCB.
If varistor is defective, there is a possibility of an abnormal power supply.
Check the correct power supply and replace the Filter PCB.
Upon checking the normal power supply, replace the Filter PCB.



End

■ Outdoor unit—No power

Forecast of cause	Power supply failure
	External cause
	Electrical components defective

Check point 1. Check installation condition

- Is the circuit breaker on or off?
- Check loose or removed connection cable.

→ If abnormal condition is found, correct it by referring to the installation manual or the *DESIGN & TECHNICAL MANUAL*.



Check point 2. Check external cause at indoor and outdoor (voltage drop or noise)

- Instant drop: Check if there is a large load electric apparatus in the same circuit.
- Momentary power failure: Check if there is a defective contact or leak current in the power supply circuit.
- Noise: Check if there is any equipment causing harmonic wave near electric line. (Neon bulb or electric equipment that may cause harmonic wave)
Check the complete insulation of grounding.



Check point 3. Check electrical components

Check the voltage of power supply.

Check if AC 207 to 253 V appears at outdoor unit terminal L—N

→ If no, go to "Check point 1" and "Check point 2".



- Check fuse in main PCB.
If fuse is open, check if the wiring between terminal and main PCB is loose, and replace the Main PCB.
- Check varistor in the Main PCB.
If varistor is defective, there is a possibility of an abnormal power supply. Check the correct power supply and replace the Main PCB.
→ Upon checking the normal power supply, replace the Main PCB.



Check point 4. Replace the main PCB

If check point 1 to 3 do not improve the symptom, replace the main PCB.



End

■ No operation (Power is on)

Forecast of cause	Setting/ Connection failure
	External cause
	Electrical components defective

Check point 1. Check indoor and outdoor installation condition

- Indoor unit:
 - Check incorrect wiring between indoor unit and remote controller.
 - Check if there is an open cable connection.
- Are these indoor unit, outdoor unit, and remote controller suitable model names to connect?

-> If there is some abnormal condition, correct it by referring to the installation manual and “DESIGN & TECHNICAL MANUAL”.



Turn off the power and check correct followings.

- Is there loose or removed communication line of indoor unit and outdoor unit?



Check point 2. Check external cause at indoor and outdoor (Voltage drop or Noise)

- Instant drop: Check if there is a large load electric apparatus in the same circuit.
- Momentary power failure: Check if there is a defective contact or leak current in the power supply circuit.
- Noise: Check if there is any equipment causing harmonic wave near electric line. (Neon bulb or electric equipment that may cause harmonic wave)
Check the complete insulation of grounding.



Check point 3. Check wired remote controller and controller PCB

Check voltage at CN13 (terminal 1—3) of main PCB.
(Power supply to remote controller)

- If it is DC 12 V, remote controller is failure. (The controller PCB is normal)
-> Replace remote controller.
- If it is DC 0 V, controller PCB is failure. (Check the remote controller once again)
-> Replace controller PCB.



Check point 4. Replace main PCB

If check point 1 to 3 do not improve the symptom, change main PCB.



End

■ No cooling/No heating

Forecast of cause	Indoor unit error
	Outdoor unit error
	Effect by surrounding environment
	Connection pipe/Connection wire failure
	Refrigeration cycle failure

Check point 1. Check Indoor unit

- Does Indoor unit fan run in the HIGH mode?
- Is air filter dirty?
- Is heat exchanger clogged?
- Check if energy save function is operated.



Check point 2. Check outdoor unit operation

- Check if outdoor unit is operating.
- Check any objects that obstruct the air flow route.
- Check if heat exchanger is clogged.
- Is the valve open?



Check point 3. Check site condition

- Is capacity of Indoor unit fitted to the room size?
- Any windows open or direct sunlight?



Check point 4. Check indoor/outdoor installation condition

- Check connection pipe (specified pipe length and pipe diameter?)
- Check any loose or removed communication line.

→ If there is an abnormal condition, correct it by referring to the installation manual or the "DESIGN & TECHNICAL MANUAL".



Check point 5. Check Refrigeration cycle

- Check if strainer is clogged (Refer to the figure below).
- Measure gas pressure, and if there is a leakage, correct it.
- Check if EEV open or there is a capillary tube defect.
Refer to outdoor unit Electronic Expansion Valve (EEV) or Capillary tube in "[Service parts information](#)" on page 03-76.
- Check compressor.
Refer to compressor in "[Service parts information](#)" on page 03-76.
Refer to inverter compressor in "[Service parts information](#)" on page 03-76.

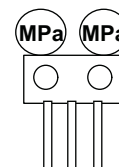

NOTE: When recharging the refrigerant, make sure to perform vacuuming, and recharge the specified amount.



End

NOTES:

- Strainer normally does not have temperature difference between inlet and outlet as shown below.

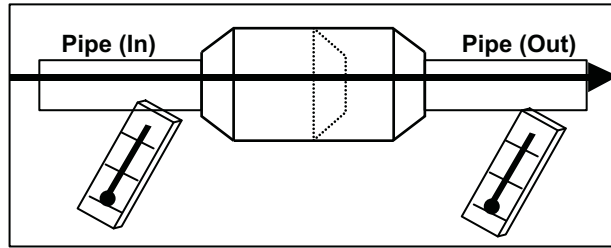

- If there is a difference like shown below, there is a possibility of inside clogged. In this case, replace the strainer.

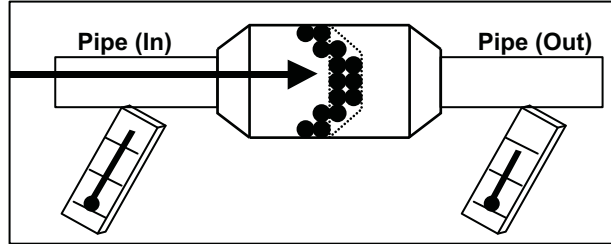

■ Abnormal noise

Forecast of cause	Abnormal installation (indoor unit/outdoor unit)
	Fan failure (indoor unit/outdoor unit)
	Compressor failure (outdoor)

Diagnosis method when abnormal noise is occurred

Abnormal noise is coming from Indoor unit.
(Check and correct followings)



- Is main unit installed in stable condition?
- Is the installation of air suction grille and front panel normal?



- Is fan broken or deformed?
- Is the screw of fan loose?
- Is there any object which obstruct the fan rotation?



End

Abnormal noise is coming from Outdoor unit.
(Check and correct followings)



- Is main unit installed in stable condition?
- Is fan guard installed normally?



- Is fan broken or deformed?
- Is the screw of fan loose?
- Is there any object which obstruct the fan rotation?



Check if vibration noise by loose bolt or contact noise of piping is happening.



Is compressor locked?

- Check Compressor
Refer to compressor and inverter compressor in "[Service parts information](#)" on page 03-76.



End

Water leaking

Forecast of cause	Erroneous installation
	Drain hose failure

Diagnosis method when water leak occurs

- Is main unit installed in stable condition?
- Is main unit broken or deformed at the time of transportation or maintenance?



- Is drain hose connection loose?
- Is there a trap in drain hose?
- Is drain hose clogged?



Is fan rotating?



End

Diagnosis method when water is spitting out

Is the filter clogged?



Check gas pressure and correct it if there was a gas leak.

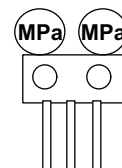

End

TROUBLESHOOTING

TROUBLESHOOTING

2-3. Troubleshooting with error code (For wireless LAN adapter)

■ E: 18. External communication error between indoor unit and wireless LAN adapter

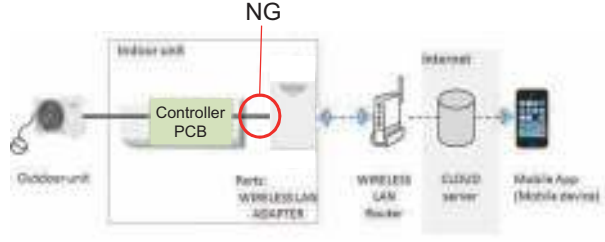
Indicator	Indoor unit	Operation indicator	1 time flash
		Timer indicator	8 time flash
		Economy indicator	Continuous flash
		Wireless LAN indicator	Flashing slowly
		Error code	E: 18
	Mobile app		E: 18.1
Detective actuator	Wireless LAN adapter PCB	After receiving a signal from the wireless LAN adapter, the same signal has not been received for 15 seconds.	
	Controller PCB		
Forecast of cause	Connection between indoor unit and wireless LAN adapter failure		
	Wireless LAN adapter PCB failure		
	Controller PCB failure		

Check point 1. Check the connection

- Check any loose or removed connection of between the wireless LAN adapter PCB and controller PCB.
-> If there is abnormal condition, correct it.
- Check the connection condition on the controller PCB.
-> If there is loose connector, open cable or mis-wiring, correct it.



Check point 2. Replace wireless LAN adapter.

If check point 1 do not improve the symptom, replace the wireless LAN adapter and cancel the registration of air conditioner on the Mobile app.
After replacing the adapter, perform the pairing on the Mobile app.

For the method of the Mobile app, refer to "[Mobile app setting method](#)" on page 03-74.



Check point 3. Replace controller PCB

If check point 1 to 2 do not improve the symptom, replace the controller PCB.



End

■ Network communication error between wireless LAN router and wireless LAN adapter

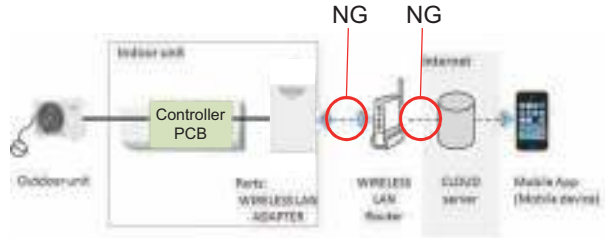
Indicator	Indoor unit	Operation indicator	No indication
		Timer indicator	No indication
		Economy indicator	No indication
		Wireless LAN indicator	Flashing slowly
		Error code	—
	Mobile app		No indication
Detective actuator	Wireless LAN router	When the not connection between wireless LAN adapter and wireless LAN router.	
	Wireless LAN adapter PCB		
Forecast of cause	Connection cable failure of wireless LAN router		
	Connection between wireless LAN adapter and wireless LAN router failure		
	Wireless LAN router failure		
	Wireless LAN adapter PCB failure		

Check point 1. Check the connection cable

Check the connection cable on the wireless LAN router.

-> If there is loose connector, open cable or mis-wiring, correct it.



Check point 2. Check the connection status.

Check the connection status to the Internet and wireless LAN router.

-> If the wireless LAN router is not connected to the Internet, check the transmission between wireless LAN products (ex. PC or game console, etc.) other than air conditioner and wireless LAN router.

If no, go to "[Check point 2-2](#)".



Check point 3. Turn on the power again of air conditioner.

If check point 1 to 2 do not improve the symptom, turn on the power of the air conditioner again and wait for 60 seconds.



Check point 4. Replace wireless LAN adapter.

If check point 3 do not improve the symptom, replace the wireless LAN adapter and cancel the registration of air conditioner on the Mobile app.
After replacing the adapter, perform the pairing on the Mobile app.

For the method of the Mobile app, refer to "[Mobile app setting method](#)" on page 03-74.



End

Check point 2-2. Check the transmission state

Check the wireless transmission state of the wireless LAN router (indicator lamp status).
-> If the wireless transmission from the wireless LAN router has not been outgoing, inquire to the wireless LAN router maker.



End

■ E: 18. Communication error

Indicator	Indoor unit	Operation indicator	1 time flash
		Timer indicator	8 time flash
		Economy indicator	Continuous flash
		Wireless LAN indicator	Flashing slowly
		Error code	E: 18
	Mobile app		E: 18.1
Detective actuator	Wireless LAN router	When the external communication error between indoor unit and wireless LAN adapter and network communication error between wireless LAN router and wireless LAN adapter has occurred simultaneously.	
	Wireless LAN adapter PCB		
	Indoor unit controller PCB		
		<p>The diagram illustrates the communication path from the Indoor unit (Controller PCB) through the Wireless LAN Adapter, Wireless LAN Router, Internet, Cloud server, and Mobile App (Mobile device). Three red circles labeled 'NG' (Not Good) indicate communication errors at the Controller PCB, the Wireless LAN Adapter, and the Wireless LAN Router.</p>	
Forecast of cause	Connection cable failure of wireless LAN router		
	Wireless LAN router failure		
	Connection between indoor unit and wireless LAN adapter failure		
	Connection between wireless LAN adapter and wireless LAN router failure		
	Wireless LAN adapter PCB failure		
	Controller PCB failure		

Check point 1. Check the connection

- Check any loose or removed connection of between the wireless LAN adapter PCB and controller PCB.
-> If there is abnormal condition, correct it.
- Check the connection condition on the controller PCB.
-> If there is loose connector, open cable or mis-wiring, correct it.



Check point 2. Replace wireless LAN adapter.

If check point 1 do not improve the symptom, replace the wireless LAN adapter and cancel the registration of air conditioner on the Mobile app.
After replacing the adapter, perform the pairing on the Mobile app.

For the method of the Mobile app, refer to "[Mobile app setting method](#)" on page 03-74.



Check point 3. Replace controller PCB

If check point 1 to 2 do not improve the symptom, replace the controller PCB.



Check point 4. Check the connection cable

Check the connection cable on the wireless LAN router.
-> If there is loose connector, open cable or mis-wiring, correct it.

**Check point 5. Check the connection status.**

Check the connection status to the Internet and wireless LAN router.
-> If the wireless LAN router is not connected to the Internet, check the transmission between wireless LAN products (ex. PC or game console, etc.) other than air conditioner and wireless LAN router.

If no, go to "[Check point 5-2](#)".

**Check point 6. Turn on the power again of air conditioner.**

If check point 1 to 2 do not improve the symptom, turn on the power of the air conditioner again and wait for 60 seconds.

**Check point 7. Replace wireless LAN adapter.**

If check point 3 do not improve the symptom, replace the wireless LAN adapter and cancel the registration of air conditioner on the Mobile app.
After replacing the adapter, perform the pairing on the Mobile app.

For the method of the Mobile app, refer to "[Mobile app setting method](#)" on page 03-74.



End

Check point 5-2. Check the transmission state

Check the wireless transmission state of the wireless LAN router (indicator lamp status).
-> If the wireless transmission from the wireless LAN router has not been outgoing, inquire to the wireless LAN router maker.



End

■ E: 18. Wireless LAN adapter non-energized

Indicator	Indoor unit	Operation indicator	1 time flash
		Timer indicator	8 time flash
		Economy indicator	Continuous flash
		Wireless LAN indicator	No indication
		Error code	E: 18
	Mobile app		No indication
Detective actuator	Indoor unit controller PCB	When the voltage (DC 12 V) does not output from the controller PCB.	
	Wireless LAN adapter PCB		
Forecast of cause		Indoor unit controller PCB failure	
		Wireless LAN adapter PCB failure	
		Wiring connection failure	

Check point 1. Check the connection.

- Check any loose or removed connection of between the wireless LAN adapter PCB and controller PCB.
-> If there is abnormal condition, correct it.
- Check the connection condition on the controller PCB.
-> If there is loose connector, open cable or mis-wiring, correct it.



Check point 2. Check the wireless LAN adapter PCB and the controller PCB

Check voltage at CN13 (terminal 1—3) of main PCB.

(Power supply to remote controller)

- If it is DC 0 V, controller PCB is failure.
-> Replace controller PCB.
- If it is DC 12 V, wireless LAN adapter PCB is failure.
-> Replace the wireless LAN adapter and cancel the registration of air conditioner on the Mobile app.

After replacing the adapter, perform the pairing on the Mobile app.

For the method of the Mobile app, refer to "[Mobile app setting method](#)" on page 03-74.



End

■ Mobile app setting method

● Air conditioner delete method

When the wireless LAN adapter is replaced, delete of all air conditioner is necessary on the mobile app.

1. Launch the mobile app.



2. Tap the  icon to display the Setting screen.



3. Tap the "Air conditioner editing".



4. Tap the air conditioner to be deleted.

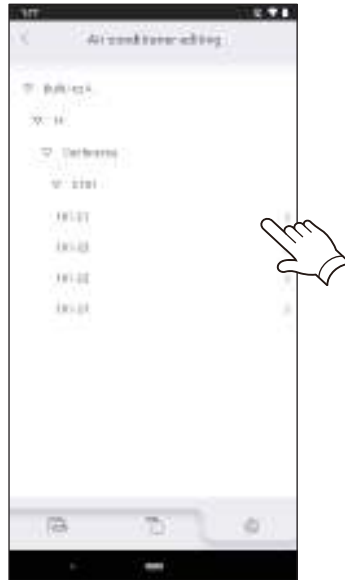

5. Tap the Delete button.



6. Tap the OK button.



7. Deletion of the air conditioner registered in the mobile app is completed.

3. Service parts information

3-1. Compressor

Diagnosis method of compressor (If outdoor unit LED displays error, refer to troubleshooting)

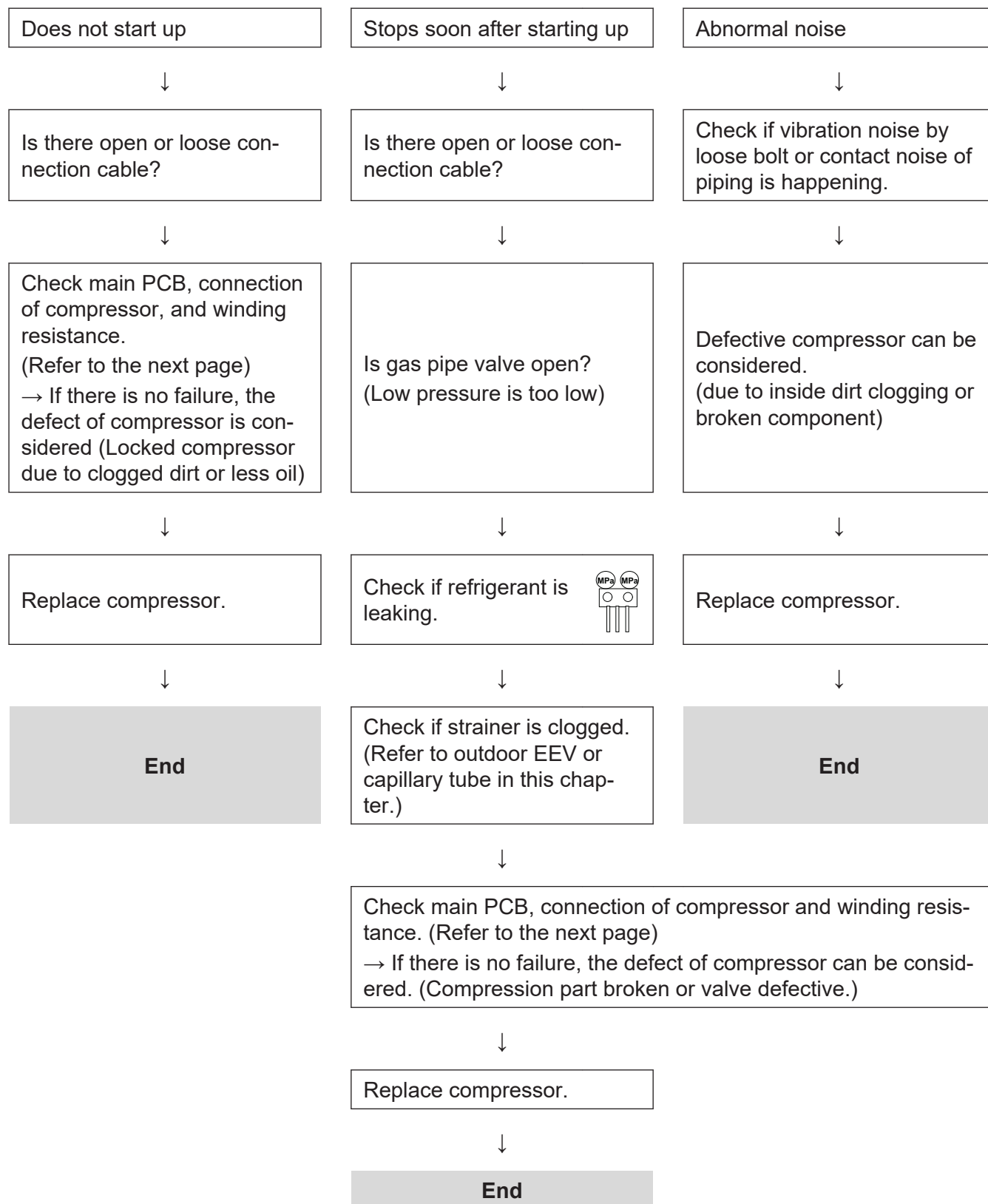

3-2. Inverter compressor

Check point 1. Check the terminal connection.

- Check the following terminal connections of the compressor. (Loosening or incorrect wiring.)

R (U): Red
S (V): White
C (W): Black

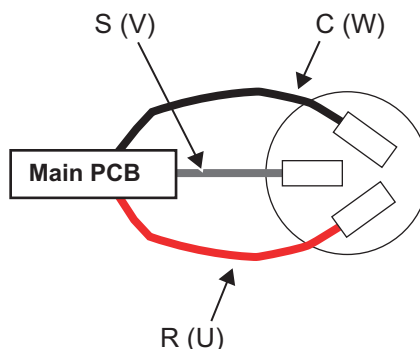

- Check the following terminal connections of the Main PCB. (Loosening or incorrect wiring.)

W400 (U): Red
W401 (V): White
W402 (W): Black

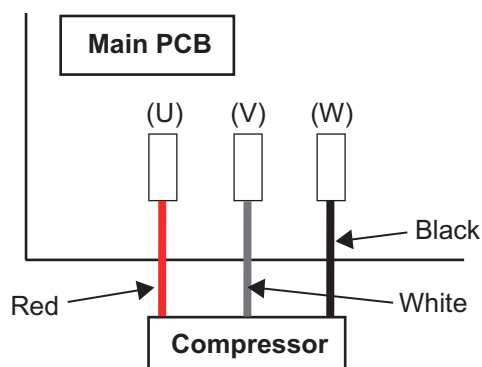

Check point 2. Check the winding resistance.

Check the winding resistance of each terminal.

Resistance value: $2.9 \Omega \pm 5\%$ at 20°C

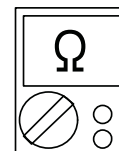
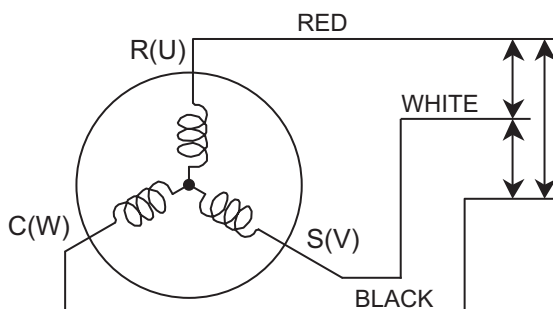

→ If the resistance value is 0Ω or infinite, replace the compressor.



Check point 3. Replace the Inverter PCB.

If check point 1 to 2 do not improve the symptom, replace the Inverter PCB.

3-3. Outdoor unit Electronic Expansion Valve (EEV)

Check point 1. Check connections

Check connection of connector. (Loose connector or open cable)

NOTE: For details of wiring diagram, refer to "Wiring diagrams" in Chapter 2. TECHNICAL DATA AND PARTS LIST on page 02-14.

Check point 2. Check coil of EEV

Remove connector, check each winding resistance of coil.

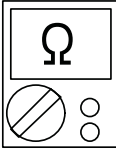
Read wire	Resistance value
White - Red	$46 \Omega \pm 3.7 \Omega$ at 20°C 
Yellow - Red	
Orange - Red	
Blue - Red	

→ If Resistance value is abnormal, replace EEV.

Check point 3. Check voltage from main PCB

Remove connector and check voltage (DC 12 V)

→ If it does not appear, replace main PCB.



Check point 4. Check noise at start up

Turn on the power and check the operation noise.

→ If an abnormal noise does not show, replace main PCB.

Check point 5. Check opening and closing operation of valve

When valve is closed, it has a temp. difference between inlet and outlet

CLOSE
 Example : Hot Gas

Pipe (In)
 Hi TEMP.

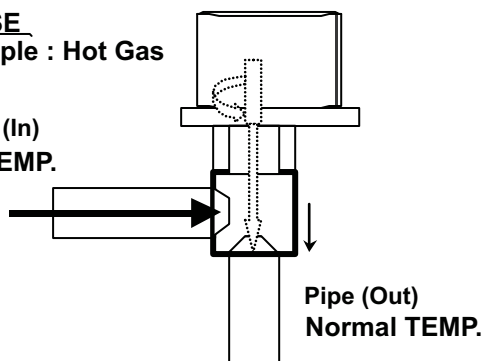

If it is open, it has no temp. difference between inlet and outlet

OPEN
 Example : Hot Gas

Pipe (In)
 Hi TEMP.

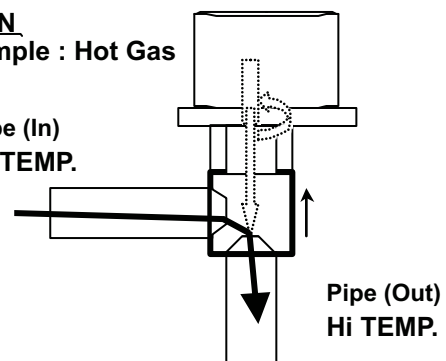

Check point 6. Check strainer

- Strainer normally does not have temperature difference between inlet and outlet as shown below.

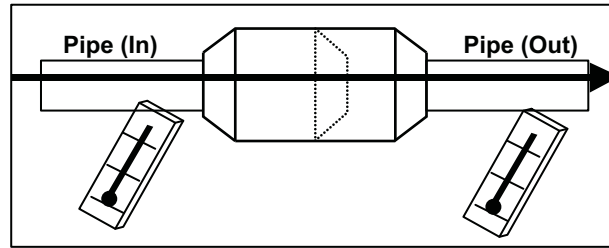

- If there is a difference like shown below, there is a possibility of inside clogged. In this case, replace the strainer.

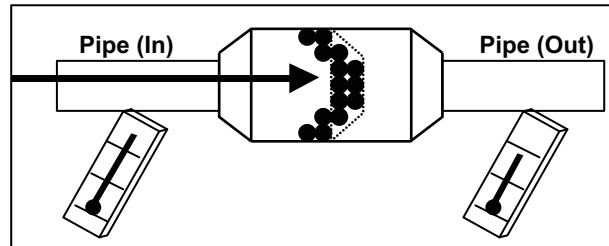

3-4. Indoor unit fan motor

Check point 1. Check rotation of fan

Rotate the fan by hand when operation is off.
 (Check if fan is caught, dropped off or locked motor)
 → If fan or bearing is abnormal, replace it.

Check point 2. Check resistance of indoor fan motor

Refer to below. Circuit-test “Vm” and “GND” terminal

NOTE: Vm: DC voltage, GND: Earth terminal

→ If they are short-circuited (below 300 kΩ), replace indoor fan motor and controller PCB.

Pin number (wire color)	Terminal function (symbol)
1 (Red)	DC voltage (Vm)
2	No function
3	No function
4 (Black)	Ground terminal (GND)
5 (White)	Control voltage (Vcc)
6 (Yellow)	Speed command (Vsp)
7 (Blue)	Feed back (FG)

3-5. Outdoor unit fan motor

Check point 1. Check rotation of fan

Rotate the fan by hand when operation is off.
 (Check if fan is caught, dropped off or locked motor)
 → If fan or bearing is abnormal, replace it.

Check point 2. Check resistance of outdoor fan motor

Refer to below. Circuit-test "Vm" and "GND" terminal

NOTE: Vm: DC voltage, GND: Ground terminal

→ If they are short-circuited (below 300 kΩ), replace outdoor fan motor and controller PCB.

Pin number (wire color)	Terminal function (symbol)
1 (Red)	DC voltage (Vm)
2	No function
3	No function
4 (Black)	Ground terminal (GND)
5 (White)	Control voltage (Vcc)
6 (Yellow)	Speed command (Vsp)
7 (Brown)	Feed back (FG)

3-6. Reactor assy

Check point 1. Appearance check

No fissures, breaks, damage, etc. at the body and winding section, terminals section?

Check point 2. Electric check

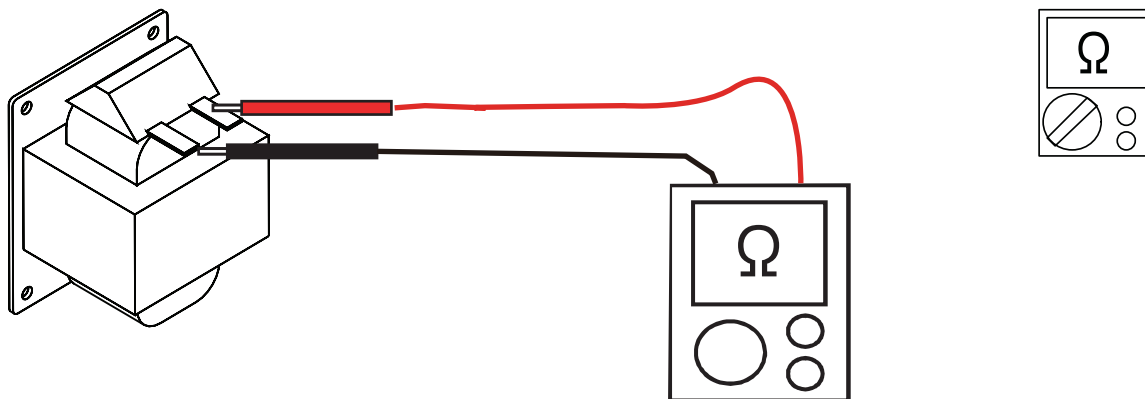

- Set the tester to the "Resistance" mode, and check for open/short between both ends of the reactor wire (or connector).
- Judge the result of 1. as follows:

Short	Normal
Open	Abnormal (open)

NOTE: Reference value of DC resistance of reactor used:
408.0 mΩ (at 20°C)

3-7. 4-way valve coil (solenoid coil)/4-way valve

Check point 1. Check connection

- Check the connection of connector P60.

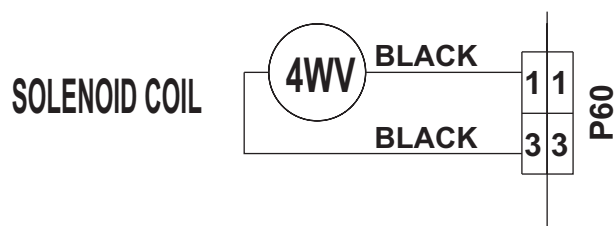

↓

Check Point 2 : Check solenoid coil

Remove P60 from PCB and check the resistance value of coil.

Resistance value $\approx 2,780 \Omega \pm 10\%$



→ If it is Open or abnormal resistance value, replace solenoid coil.

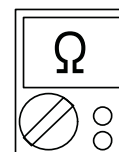

↓

Check Point 3: Check the 4-way valve operation

Check each piping temperature, and confirm the location of the valve by the temperature difference

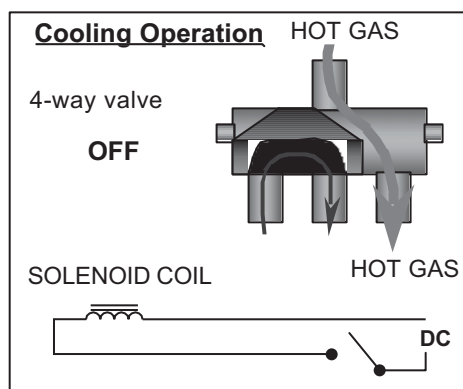
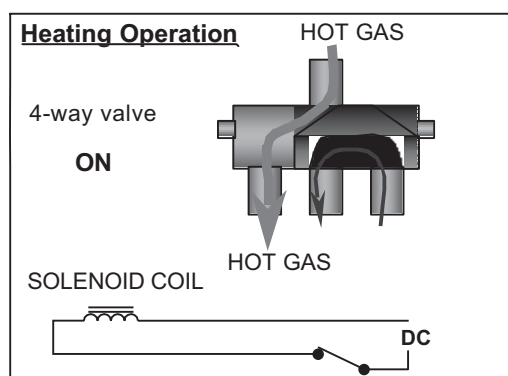

→ If the valve location is not proper, replace the 4-way valve.

↓

Check Point 4: Replace Main PCB

If none of Checks 1 to 3 apply, replace the Main PCB.

4. Thermistor resistance values

4-1. Indoor unit

■ Room temperature thermistor

Temperature (°C)	Resistance (kΩ)	Voltage (V)
-10.0	58.25	0.73
-5.0	44.03	0.93
0.0	33.62	1.15
5.0	25.93	1.39
10.0	20.18	1.66
15.0	15.84	1.94
20.0	12.54	2.22
25.0	10.00	2.50
30.0	8.04	2.77
35.0	6.51	3.03
40.0	5.30	3.27
45.0	4.35	3.49

■ Heat exchanger temperature thermistor

Temperature (°C)	Resistance (kΩ)	Voltage (V)
-30.0	1,131.91	0.21
-25.0	804.52	0.29
-20.0	579.59	0.40
-15.0	422.89	0.53
-10.0	312.27	0.69
-5.0	233.21	0.88
0.0	176.03	1.10
5.0	134.23	1.36
10.0	103.34	1.63
15.0	80.28	1.92
20.0	62.91	2.21
25.0	49.70	2.51
30.0	39.57	2.79
35.0	31.74	3.06
40.0	25.64	3.30
45.0	20.85	3.53
50.0	17.06	3.73
55.0	14.05	3.90
60.0	11.64	4.05
65.0	9.69	4.19

4-2. Outdoor unit

■ Discharge temperature thermistor

Temperature (°C)	Resistance (kΩ)	Voltage (V)
-30.0	1,013.11	0.06
-25.0	729.09	0.09
-20.0	531.56	0.12
-15.0	392.31	0.16
-10.0	292.91	0.21
-5.0	221.09	0.28
0.0	168.60	0.36
5.0	129.84	0.46
10.0	100.91	0.57
15.0	79.12	0.71
20.0	62.55	0.86
25.0	49.84	1.03
30.0	40.01	1.23
35.0	32.35	1.43
40.0	26.34	1.65
45.0	21.58	1.88
50.0	17.79	2.11
55.0	14.75	2.34
60.0	12.30	2.57
65.0	10.32	2.79
70.0	8.69	3.00
75.0	7.36	3.19
80.0	6.27	3.37
85.0	5.36	3.54
90.0	4.60	3.69
95.0	3.96	3.83
100.0	3.43	3.96
105.0	2.98	4.07
110.0	2.60	4.17
115.0	2.27	4.26
120.0	2.00	4.33

■ Heat exchanger temperature thermistor

Temperature (°C)	Resistance (kΩ)	Voltage (V)
-30.0	95.58	0.24
-25.0	68.90	0.32
-20.0	50.31	0.43
-15.0	37.19	0.57
-10.0	27.81	0.73
-5.0	21.02	0.92
0.0	16.05	1.14
5.0	12.38	1.39
10.0	9.63	1.65
15.0	7.56	1.93
20.0	5.98	2.21
25.0	4.77	2.49
30.0	3.84	2.77
35.0	3.11	3.02
40.0	2.53	3.26
45.0	2.08	3.48
50.0	1.71	3.68
55.0	1.42	3.85
60.0	1.19	4.00
65.0	1.00	4.13
70.0	0.84	4.25
75.0	0.71	4.35
80.0	0.61	4.43

■ Heat exchanger (Middle) temperature thermistor

Temperature (°C)	Resistance (kΩ)	Voltage (V)
-30.0	95.58	0.24
-25.0	68.90	0.32
-20.0	50.31	0.43
-15.0	37.19	0.57
-10.0	27.81	0.73
-5.0	21.02	0.92
0.0	16.05	1.14
5.0	12.38	1.39
10.0	9.63	1.65
15.0	7.56	1.93
20.0	5.98	2.21
25.0	4.77	2.49
30.0	3.84	2.77
35.0	3.11	3.02
40.0	2.53	3.26
45.0	2.08	3.48
50.0	1.71	3.68
55.0	1.42	3.85
60.0	1.19	4.00
65.0	1.00	4.13
70.0	0.84	4.25
75.0	0.71	4.35
80.0	0.61	4.43

■ Outdoor temperature thermistor

Temperature (°C)	Resistance (kΩ)	Voltage (V)
-30.0	224.33	0.73
-25.0	159.71	0.97
-20.0	115.24	1.25
-15.0	84.21	1.56
-10.0	62.28	1.90
-5.0	46.58	2.26
0.0	35.21	2.61
5.0	26.88	2.94
10.0	20.72	3.25
15.0	16.12	3.52
20.0	12.64	3.76
25.0	10.00	3.97
30.0	7.97	4.14
35.0	6.40	4.28
40.0	5.18	4.41
45.0	4.21	4.51
50.0	3.45	4.59
55.0	2.85	4.65

4. CONTROL AND FUNCTIONS

CONTENTS

4. CONTROL AND FUNCTIONS

1. Rotation number control of compressor.....	04-1
1-1. Cooling operation	04-1
1-2. Heating operation	04-3
1-3. Dry operation	04-5
1-4. Rotation number of compressor at normal start-up	04-6
1-5. Limitation of compressor rotation number by outdoor temperature.....	04-7
2. Auto changeover operation.....	04-9
3. Fan control.....	04-11
3-1. Indoor fan control.....	04-11
3-2. Outdoor fan control	04-15
4. Louver control	04-19
4-1. Horizontal louver control	04-19
4-2. Vertical louver control	04-19
4-3. Swing operation.....	04-20
5. Timer operation control	04-21
5-1. Wireless remote control	04-21
5-2. Wired remote control	04-23
6. Defrost operation control	04-26
6-1. Defrost operation in heating operation stopped	04-27
7. Various control.....	04-28
7-1. Auto restart.....	04-28
7-2. MANUAL AUTO operation	04-28
7-3. Forced cooling operation	04-29
7-4. 10 °C HEAT operation	04-29
7-5. ECONOMY operation	04-29
7-6. POWERFUL operation	04-30
7-7. Fresh air control	04-30
7-8. Compressor preheating operation	04-30
7-9. External electrical heater control	04-31
7-10. Electronic expansion valve control	04-31
7-11. Prevention to restart for 3 minutes (3 minutes st)	04-31
7-12. 4-way valve control.....	04-32
7-13. Human sensor for energy saving	04-32
7-14. Outdoor unit low noise operation	04-32
7-15. Heat Clean operation	04-33
7-16. Unit status monitoring and the detected value indication	04-36
8. Various protections.....	04-38
8-1. Discharge gas temperature over-rise prevention control	04-38
8-2. Anti-freezing control (cooling and dry mode)	04-38
8-3. Current release control	04-39

CONTENTS (continued)

8-4. Low outdoor temperature protection	04-40
8-5. High temperature and high pressure release control	04-41

1. Rotation number control of compressor

1-1. Cooling operation

A sensor (room temperature thermistor) built in the indoor unit body will usually perceive difference or variation between a set temperature and present room temperature, and controls the operation rotation number of the compressor.

- If the room temperature is 6.0°C higher than a set temperature, the operation rotation number of compressor will attain to maximum performance.
- If the room temperature is 1.0°C lower than a set temperature, the compressor will be stopped.
- When the room temperature is within the range of +6.0°C to -1.0°C of the setting temperature, the rotation number of compressor is controlled within the range shown in the table below. However, the maximum rotation number is limited in the range shown in the figure below based on the indoor fan mode and the outdoor temperature.

- **Rotation number range of compressor**

Unit: rps

Model name	Minimum rotation number	Maximum rotation number
ASEH07KJCAL ASEH07KJCALB	8	59
ASEH09KJCAL ASEH09KJCALB	8	64
ASEH12KJCAL ASEH12KJCALB	8	83
ASEH14KJCAL ASEH14KJCALB	8	91

• Limit of maximum speed based on outdoor temperature

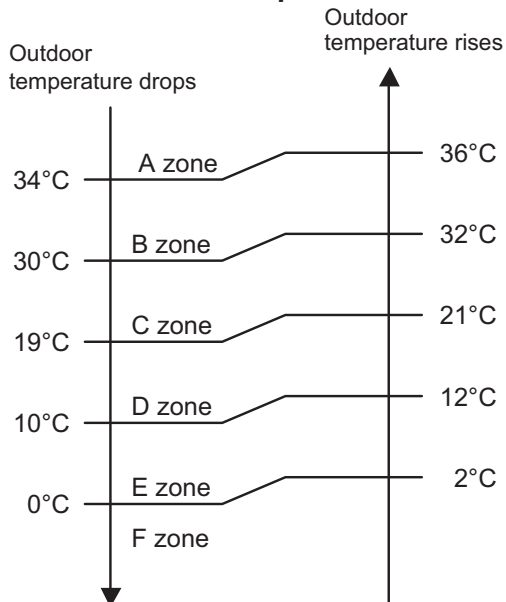

Unit: rps

Model name	Outdoor temperature zone	Indoor unit fan mode					
		HIGH	MED-HIGH	MED	MED-LOW	LOW	QUIET
ASEH07KJCAL ASEH07KJCALB	A zone	59	42	39	36	32	26
	B zone	59	42	39	36	32	26
	C zone	59	42	39	36	32	26
	D zone	59	54	42	42	39	26
	E zone	59	54	42	42	39	26
	F zone	59	54	42	42	39	26
ASEH09KJCAL ASEH09KJCALB	A zone	64	46	39	36	32	26
	B zone	64	46	39	36	32	26
	C zone	64	46	39	36	32	26
	D zone	59	54	42	42	39	26
	E zone	59	54	42	42	39	26
	F zone	59	54	42	42	39	26
ASEH12KJCAL ASEH12KJCALB	A zone	83	59	51	42	36	30
	B zone	83	59	51	42	36	30
	C zone	70	59	51	42	34	30
	D zone	76	76	64	59	54	30
	E zone	76	76	64	59	54	30
	F zone	76	76	64	59	54	30
ASEH14KJCAL ASEH14KJCALB	A zone	91	70	54	42	36	30
	B zone	91	70	54	42	36	30
	C zone	91	64	51	42	34	30
	D zone	83	76	64	59	54	30
	E zone	83	76	64	59	54	30
	F zone	83	76	64	59	54	30

CONTROL AND FUNCTIONS

CONTROL AND FUNCTIONS

1-2. Heating operation

A sensor (room temperature thermistor) built in indoor unit body will usually perceive difference or variation between setting temperature and present room temperature, and controls operation rotation number of compressor.

- If the room temperature is 6.0 °C lower than a set temperature, the operation rotation number of compressor will attain to maximum performance.
- If the room temperature is 1.0°C higher than a set temperature, the compressor will be stopped.
- When the room temperature is within the range of +1.0°C to -6.0°C of the setting temperature, the rotation number of compressor is controlled within the range shown below.

- **Rotation number range of compressor**

Unit: rps

Model name	Minimum rotation number	Maximum rotation number
ASEH07KJCAL	8	125
ASEH07KJCALB		
ASEH09KJCAL		
ASEH09KJCALB		
ASEH12KJCAL		
ASEH12KJCALB		
ASEH14KJCAL		
ASEH14KJCALB		

• **Limit of maximum speed based on outdoor temperature**

In heating operation, maximum rotation number is defined by outdoor temperature and fan mode.

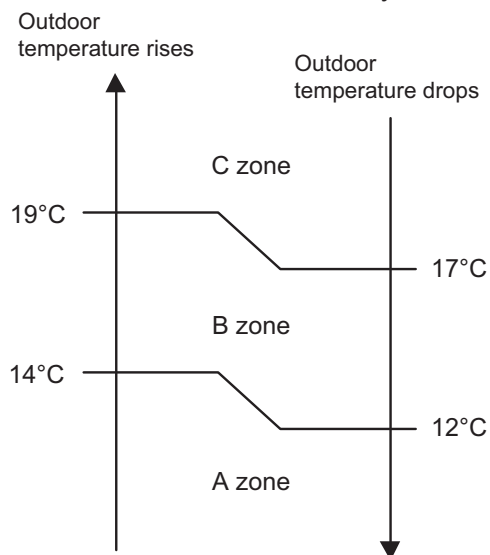

Unit: rps

Model name	Outdoor temperature zone	Indoor unit fan mode					
		HIGH	MED-HIGH	MED	MED-LOW	LOW	QUIET
ASEH07KJCAL ASEH07KJCALB	C zone	91	91	91	91	91	42
	B zone	91	91	91	91	91	54
	A zone	115	115	115	115	115	115
ASEH09KJCAL ASEH09KJCALB	C zone	108	108	108	108	108	42
	B zone	108	108	108	108	108	54
	A zone	125	125	125	125	125	125
ASEH12KJCAL ASEH12KJCALB	C zone	108	108	108	108	108	51
	B zone	108	108	108	108	108	59
ASEH14KJCAL ASEH14KJCALB	A zone	125	125	125	125	125	125

1-3. Dry operation

The rotation number of compressor shall change according to the temperature, set temperature, and room temperature variation which the room temperature sensor of the indoor unit has detected as shown in the table below.

Zone is defined by set temperature and room temperature.

- **Rotation number range of compressor**

Unit: rps

Model name	Outdoor temperature zone	Operating rotation number
ASEH07KJCAL	X zone	26
ASEH07KJCALB	J zone	16
ASEH09KJCAL	Y zone	0
ASEH07KJCALB		
ASEH12KJCAL	X zone	36
ASEH12KJCALB	J zone	20
ASEH14KJCAL	Y zone	0
ASEH14KJCALB		

- **Compressor control based on room temperature**

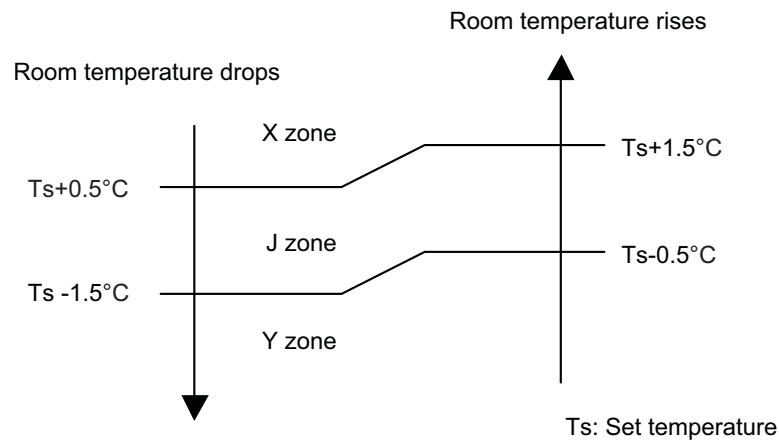

1-4. Rotation number of compressor at normal start-up

Rotation number of compressor soon after starting is controlled as below.

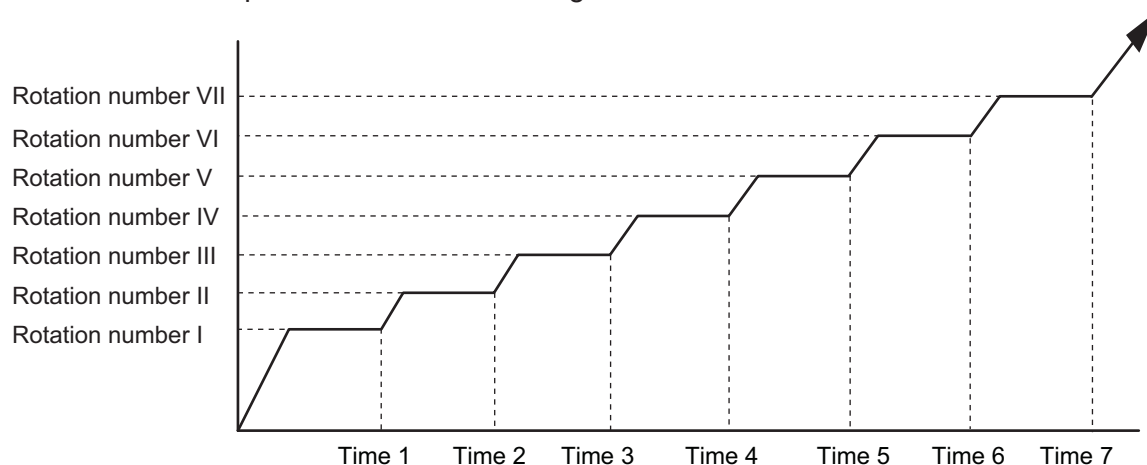

Rotation number (rpm)	I	II	III	IV	V	VI	VII
	24	58	70	80	87	96	107
Time (sec)	1	2	3	4	5	6	7
	60	140	170	220	280	360	430

CONTROL AND FUNCTIONS

CONTROL AND FUNCTIONS

1-5. Limitation of compressor rotation number by outdoor temperature

The minimum rotation number of compressor is limited by outdoor temperature as below.

- **Cooling/Dry mode**

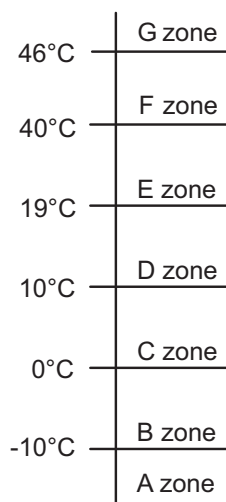

Unit: rps

Model name	Outdoor temperature zone	Limitation of compressor rotation number
AOEH07KJCA AOEH09KJCA	A zone	36
	B zone	36
	C zone	36
	D zone	36
	E zone	12
	F zone	14
	G zone	20
AOEH12KJCA AOEH14KJCA	A zone	39
	B zone	39
	C zone	39
	D zone	39
	E zone	12
	F zone	30
	G zone	34

- Heating mode

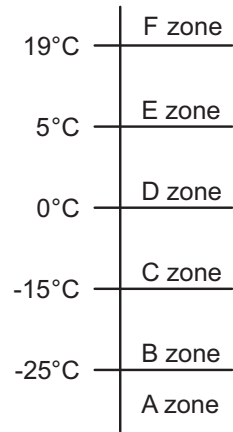

Unit: rps

Model name	Outdoor temperature zone	Limitation of compressor rotation number
AOEH07KJCA AOEH09KJCA	A zone	42
	B zone	42
	C zone	36
	D zone	22
	E zone	12
	F zone	12
AOEH12KJCA AOEH14KJCA	A zone	48
	B zone	48
	C zone	42
	D zone	24
	E zone	12
	F zone	12

2. Auto changeover operation

When the air conditioner is set to AUTO mode by remote controller, operation starts in the optimum mode from among heating, cooling, and monitoring modes. During operation, the optimum mode is automatically switched in accordance with temperature changes. The temperature can be set between 18°C and 30°C in 1.0°C steps.

- When operation starts, indoor fan and outdoor fan are operated for around 1 minute. Room temperature and outdoor temperature are sensed, and the operation mode is selected in accordance with the table below.

Room temperature	Operation mode
$Tr > Ts + 2^{\circ}\text{C}$	Cooling
$Ts + 2^{\circ}\text{C} \geq Tr \geq Ts - 2^{\circ}\text{C}$	Middle zone
$Tr < Ts - 2^{\circ}\text{C}$	Heating

Tr: Room temperature

Ts: Setting temperature

NOTE: When the operation mode is middle zone, indoor unit operation mode is selected as below.

- Same operation mode is selected as outdoor unit.
If outdoor unit is operating in cooling and heating mode, indoor unit will be operated by the same operation mode.
- Selected by outdoor temperature.
If outdoor unit is operating in other than cooling and heating mode, indoor unit will be operated according to the outdoor temperature as below.

Outdoor temp.	Operation mode
25°C or more	Cooling
Less than 25°C	Heating

- When the compressor was stopped for 6 consecutive minutes by temperature control function after the cooling or heating mode was selected as above, operation is switched to monitoring mode and the operation mode selection is done again.
- When the middle zone is selected on the predetermining of the operation mode, the operation mode before the changing to the monitoring mode is selected.

Operation flow chart

Ts: Setting temperature

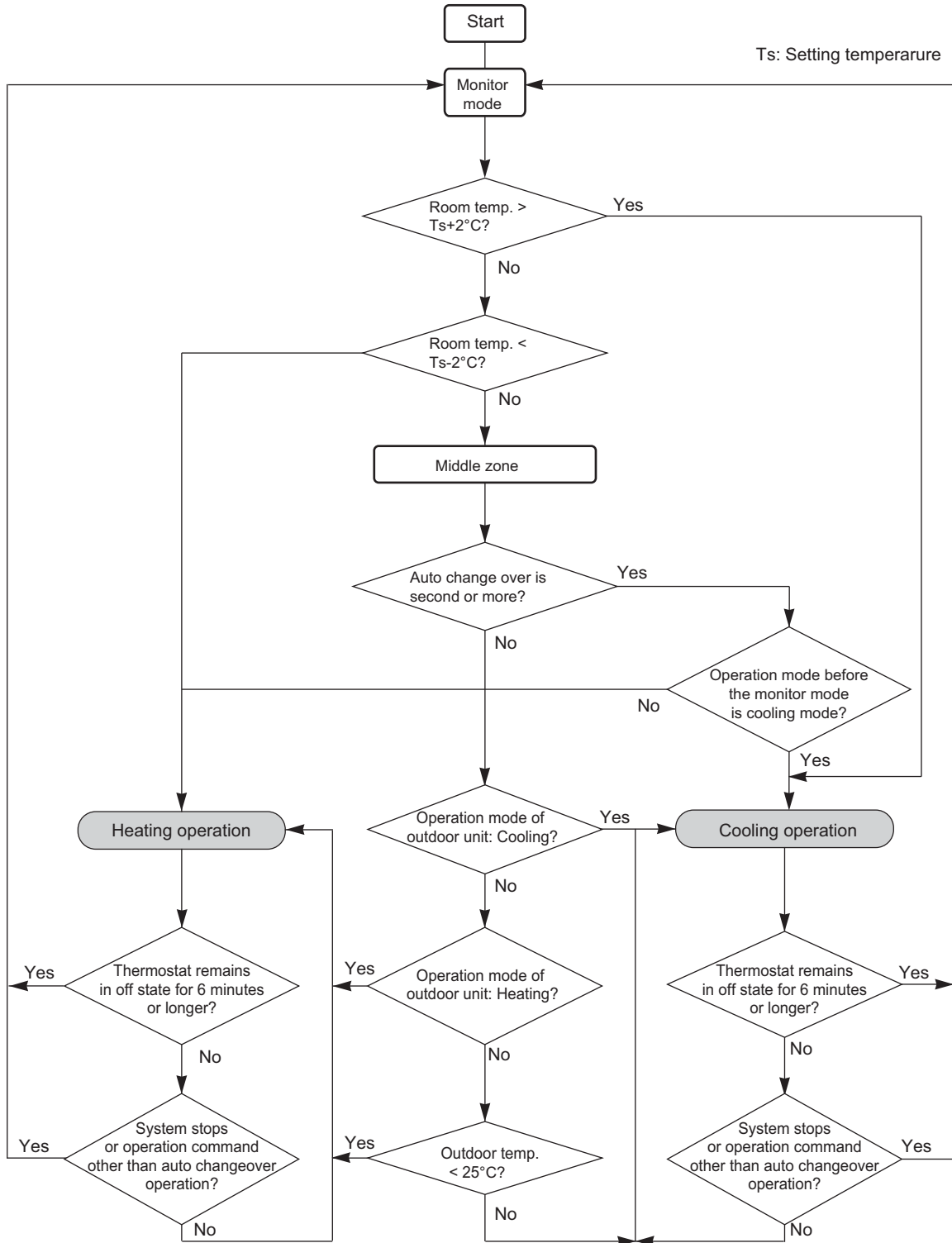

CONTROL AND FUNCTIONS

CONTROL AND FUNCTIONS

3. Fan control

Tr: Room temperature

Ts: Setting temperature

3-1. Indoor fan control

■ Fan speed

Indoor fan speed is defined as below.

Operation mode	Fan mode	Speed (rpm)			
		ASEH07KJCAL ASEH07KJCAL B	ASEH09KJCAL ASEH07KJCAL B	ASEH12KJCAL ASEH12KJCAL B	ASEH14KJCAL ASEH14KJCAL B
		Heating	POWERFUL	1,130	1,130
HIGH	1,020		1,020	1,160	1,290
MED-HIGH	910		910	1,050	1,120
MED	810		810	930	960
MED-LOW	740		740	820	820
LOW	670		670	710	710
QUIET	590		590	610	610
Cool air prevention	550		550	610	610
S-LOW	500	500	550	550	
Cooling/Fan	POWERFUL	1,060	1,130	1,300	1,390
	HIGH	990	1,020	1,160	1,290
	MED-HIGH	880	910	1,050	1,120
	MED	810	810	930	960
	MED-LOW	740	740	820	820
	LOW	670	670	710	710
	QUIET	570	570	610	610
	Soft quiet	500*1	500*1	550*1	550*1
S-LOW	500*2	500*2	550*2	550*2	
Dry		X zone: 570 J zone: 570	X zone: 570 J zone: 570	X zone: 710 J zone: 710	X zone: 710 J zone: 710

*1: Fan mode only

*2: Cooling mode only

■ Fan operation

Airflow can be switched in 7 steps such as AUTO, QUIET, LOW, MED-LOW, MED, MED-HIGH, HIGH while indoor unit fan only runs.

When fan mode is set at AUTO, it operates on MED fan speed.

■ Cooling operation

Switch the airflow AUTO, and indoor fan motor will run according to room temperature, as below. On the other hand, if switched in HIGH—QUIET, indoor motor will run at a constant airflow of COOL operation modes QUIET, LOW, MED, HIGH as shown in “Fan speed” above.

Airflow change over (Cooling: Auto)

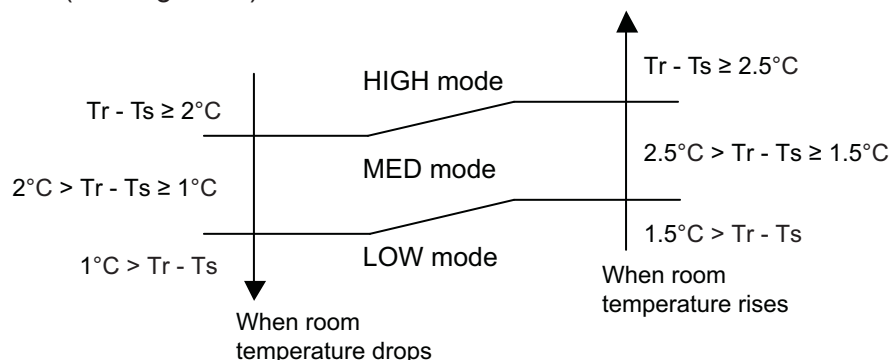

■ Dry operation

During dry operation, fan speed setting can not be changed as shown in “Fan speed” above.

■ Heating operation

Switch the airflow AUTO, and the indoor fan motor will run according to a room temperature, as below.

On the other hand, if switched in HIGH—QUIET, the indoor motor will run at a constant airflow of HEAT operation modes QUIET, LOW, MED, HIGH as shown in “Fan speed” above.

Airflow change over (Heating: Auto)

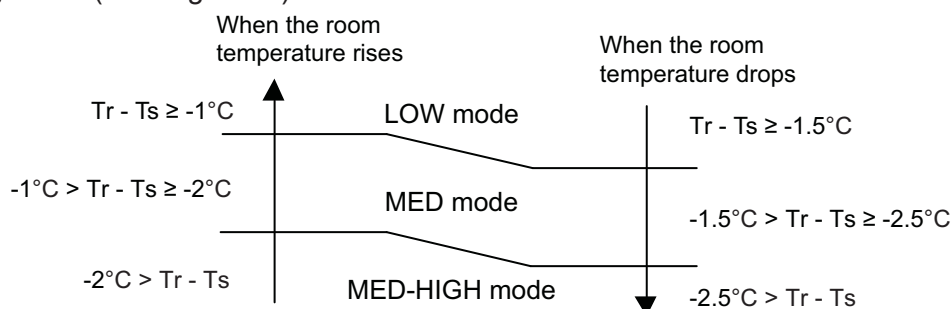

■ Cool air prevention control (heating mode)

The maximum value of the indoor fan speed is set as shown below, based on the detected temperature by the indoor heat exchanger sensor on heating mode.

- Normal operation

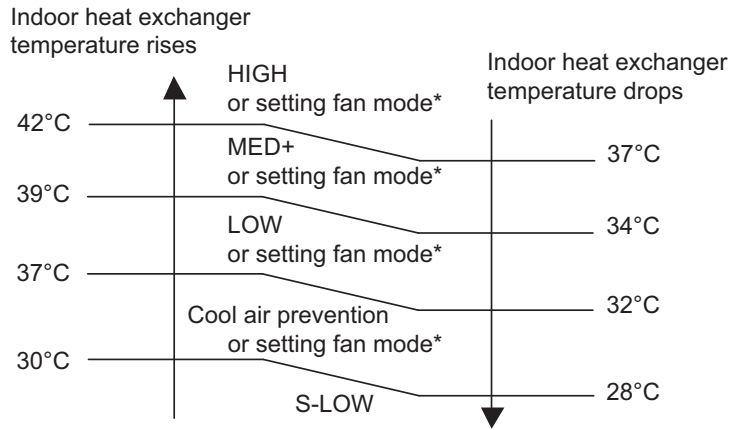

*: Lower speed is selected.

7 minutes later:

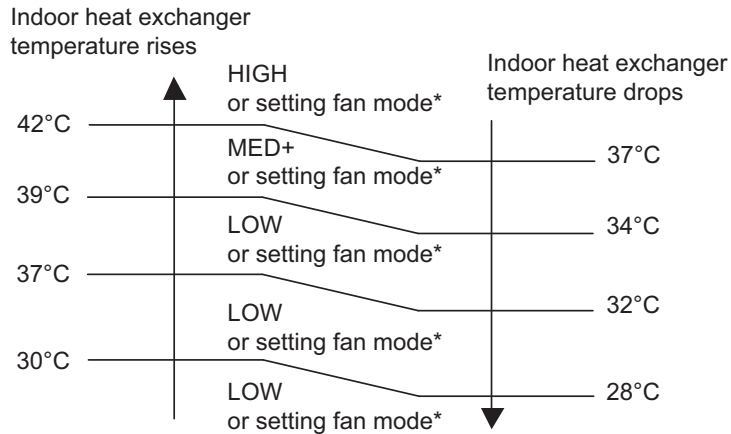

*: Lower speed is selected.

CONTROL AND FUNCTIONS

CONTROL AND FUNCTIONS

• **Powerful operation**

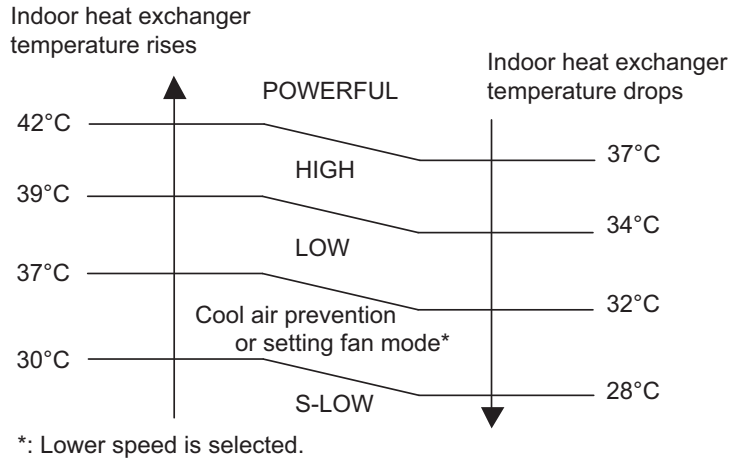

7 minutes later:

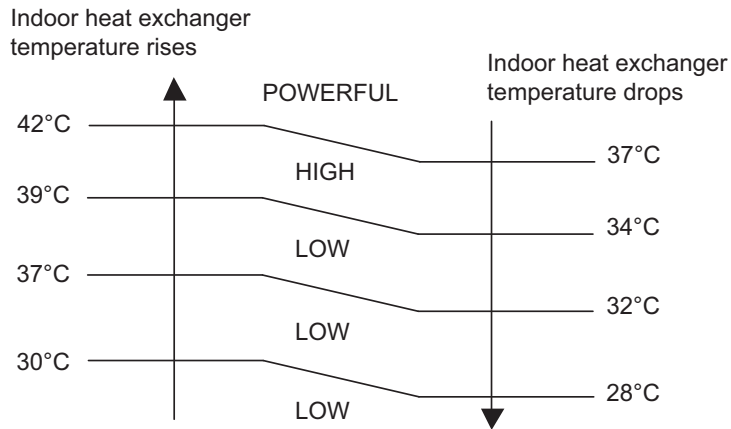

• **10 °C HEAT operation**

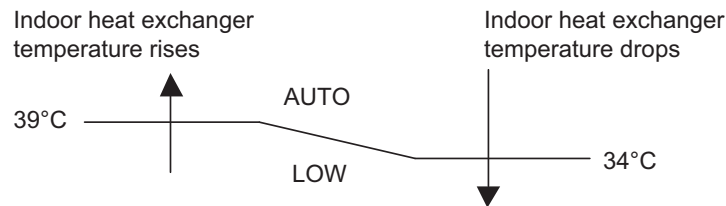

■ **Moisture return prevention control (cooling and dry mode)**

Switch the airflow AUTO at cooling mode, and the indoor fan motor will run as shown below.

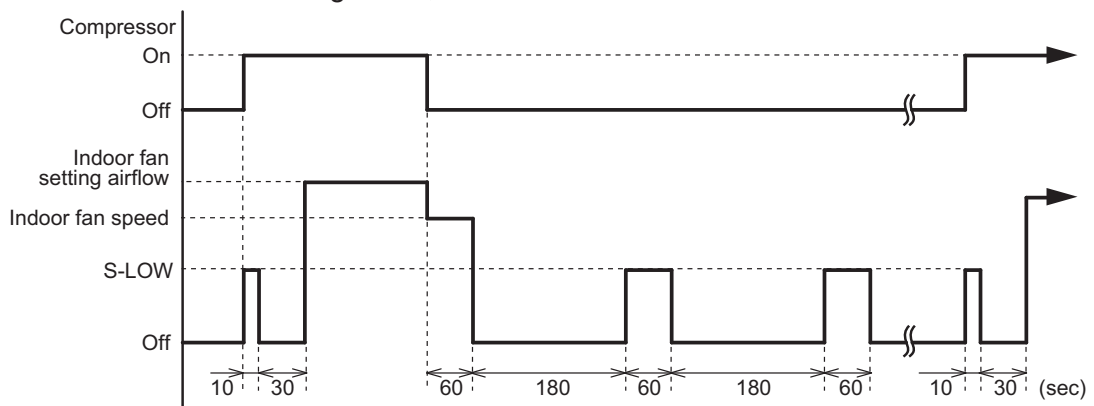

3-2. Outdoor fan control

■ Outdoor fan motor

This outdoor unit has a DC fan motor. (Control method is different between AC and DC motors.)

■ Fan speed

● Model: AOEH07KJCA

Fan speed is defined by outdoor temperature and rotation number of the compressor.

• Outside air temperature zone selection

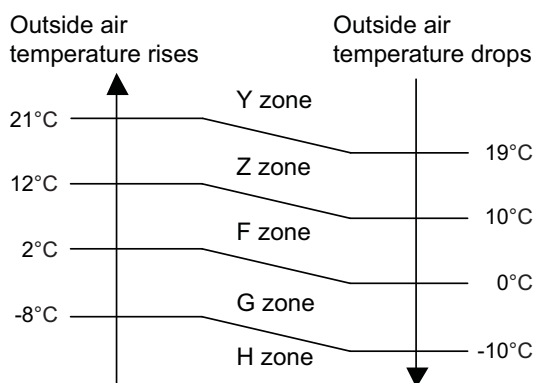

Unit: rpm

Fan step	Cooling	Heating	Dry	Cooling or dry at low outdoor temp.				
	Y zone		Y zone	Z zone	F zone	G zone	H zone	
S-HIGH2	—	1,030	—	—	—	—	—	—
S-HIGH1	990	980	—	—	—	—	—	—
HIGH	990	980	—	—	—	—	—	—
10	—	800	—	—	—	—	—	—
9	990	800	990	200	180	160	160	
8	800	800	800	200	180	160	160	
7	800	800	800	200	180	160	160	
6	800	740	800	200	180	160	160	
5	740	680	740	200	180	160	160	
4	700	680	700	200	180	160	160	
3	550	550	550	200	180	160	160	
2	550	450	550	200	180	160	160	
1	480	450	480	200	180	160	160	

NOTE: After defrost control on the heating mode, the fan speed is kept higher regardless of the rotation number of compressor.

Fan speed after defrost control: 1,030 rpm

● Model: AOEH09KJCA

Fan speed is defined by outdoor temperature and rotation number of the compressor.

• Outside air temperature zone selection

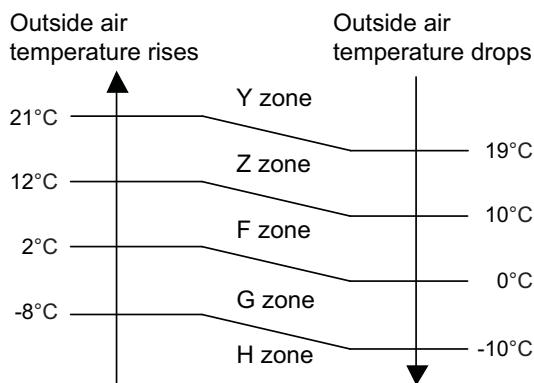

Unit: rpm

Fan step	Cooling	Heating	Dry	Cooling or dry at low outdoor temp.			
	Y zone		Y zone	Z zone	F zone	G zone	H zone
S-HIGH2	—	1,070	—	—	—	—	—
S-HIGH1	990	980	—	—	—	—	—
HIGH	990	980	—	—	—	—	—
10	—	800	—	—	—	—	—
9	990	800	990	200	180	160	160
8	800	800	800	200	180	160	160
7	800	800	800	200	180	160	160
6	800	740	800	200	180	160	160
5	740	710	740	200	180	160	160
4	700	710	700	200	180	160	160
3	550	550	550	200	180	160	160
2	550	450	550	200	180	160	160
1	480	450	480	200	180	160	160

NOTE: After defrost control on the heating mode, the fan speed is kept higher regardless of the rotation number of compressor.

Fan speed after defrost control: 1,070 rpm

● Model: AOEH12KJCA

Fan speed is defined by outdoor temperature and rotation number of the compressor.

• Outside air temperature zone selection

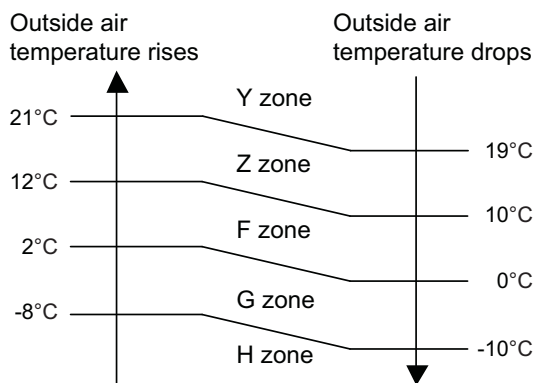

Unit: rpm

Fan step	Cooling	Heating	Dry	Cooling or dry at low outdoor temp.			
	Y zone		Y zone	Z zone	F zone	G zone	H zone
S-HIGH2	—	1,120	—	—	—	—	—
S-HIGH1	990	1,120	—	—	—	—	—
HIGH	990	1,120	—	—	—	—	—
10	—	1,120	—	—	—	—	—
9	990	1,120	990	250	220	190	190
8	870	1,120	870	250	220	190	190
7	870	870	870	250	220	190	190
6	870	870	870	250	220	190	190
5	870	660	870	220	190	170	170
4	570	660	570	220	190	170	170
3	570	500	570	220	190	170	170
2	570	500	570	220	190	170	170
1	520	500	520	220	190	170	170

NOTE: After defrost control on the heating mode, the fan speed is kept higher regardless of the rotation number of compressor.

Fan speed after defrost control: 1,120 rpm

● Model: AOEH14KJCA

Fan speed is defined by outdoor temperature and rotation number of the compressor.

• Outside air temperature zone selection

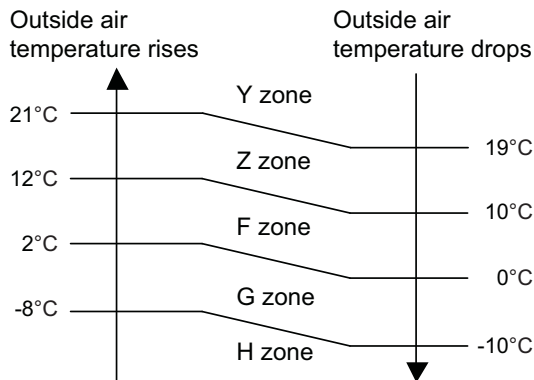

Unit: rpm

Fan step	Cooling	Heating	Dry	Cooling or dry at low outdoor temp.				
	Y zone		Y zone	Z zone	F zone	G zone	H zone	
S-HIGH2	—	1,120	—	—	—	—	—	—
S-HIGH1	990	1,120	—	—	—	—	—	—
HIGH	990	1,120	—	—	—	—	—	—
10	—	1,120	—	—	—	—	—	—
9	990	1,120	990	250	220	190	190	190
8	870	1,120	870	250	220	190	190	190
7	870	950	870	250	220	190	190	190
6	870	950	870	250	220	190	190	190
5	870	660	870	220	190	170	170	170
4	570	660	570	220	190	170	170	170
3	570	500	570	220	190	170	170	170
2	570	500	570	220	190	170	170	170
1	520	500	520	220	190	170	170	170

NOTE: After defrost control on the heating mode, the fan speed is kept higher regardless of the rotation number of compressor.

Fan speed after defrost control: 1,120 rpm

4. Louver control

4-1. Horizontal louver control

Each time the button is pressed, the airflow direction range will change as below:

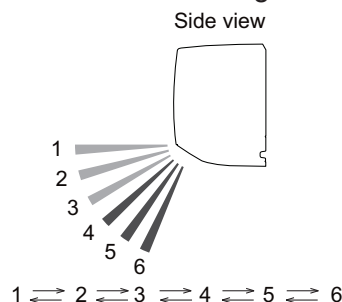

- Remote controller display is not changed.
- Up/down airflow direction is set automatically as shown, in accordance with the type of operation selected.

Cooling / Dry mode : Horizontal flow 1

Heating mode : Downward flow 6

- During AUTO operation, for the first a few minutes after beginning operation, airflow will be horizontal 1; the air direction cannot be adjusted during this period. The airflow direction setting will temporarily become 1 when the temperature of the airflow is low at the start of the Heating mode.
- After beginning of AUTO/HEAT mode operated and automatic defrosting operation, the airflow will be horizontal 1. However, the airflow direction cannot be adjusted at beginning AUTO operation mode.

4-2. Vertical louver control

Each time the button is pressed, the airflow direction range will change as below:

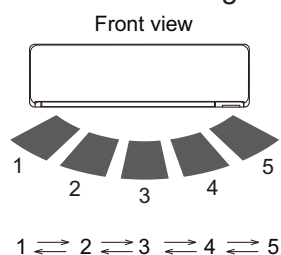

Remote controller display is not changed.

4-3. Swing operation

- To select up/down airflow swing operation
When the swing signal is received, the horizontal louver starts to swing.
 - Swinging range
 - Cooling mode/dry mode/fan mode (1 to 3): 1 ↔ 4
 - Heating mode/fan mode (4 to 6): 3 ↔ 6
 - When the indoor fan is S-LOW or stop mode, the swing operation is interrupted and it stops at either upper end or bottom end.

- To select left/right airflow swing operation
When the swing signal is received, the vertical louver starts to swing.
 - Swinging range
 - All mode: 1 ↔ 5
 - When the indoor fan is S-LOW or stop mode, the swing operation is interrupted and it stops at either left end or right end.

- To select up/down and left/right airflow swing operation
When the swing signal is received, both of the vertical and the horizontal louvers start to swing.

5. Timer operation control

5-1. Wireless remote control

On/Off timer	Program timer	Sleep timer	Weekly timer
○	○	○	○

● On/Off timer

- Off timer: When the clock reaches the set timer, the air conditioner will be turned off.

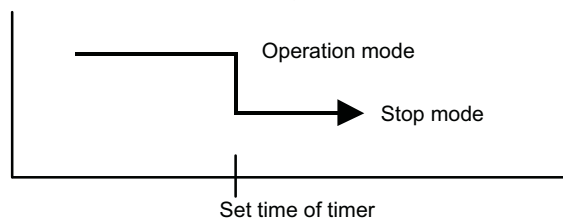

- On timer: When the clock reaches the set timer, the air conditioner will be turned on.

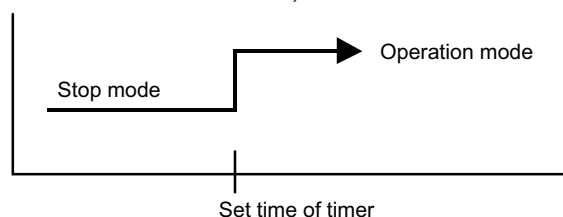

● Program timer

- The program timer allows the off timer and the on timer to be used in combination one time.

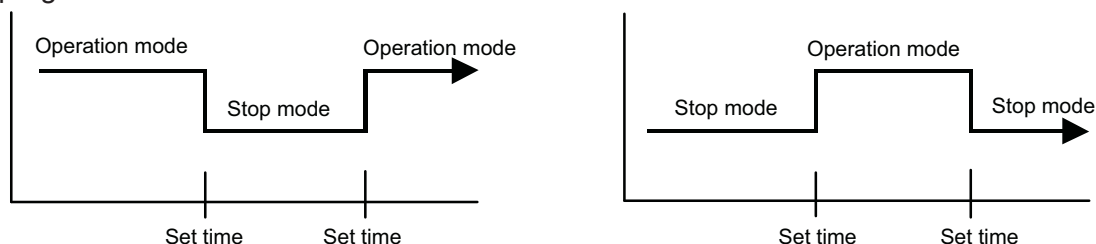

- Operation will start from the timer setting (either off timer and on timer) whichever is closest to the clock current timer setting. The order of operations is indicated by the allow in the remote controller screen.
- Sleep timer operation cannot be combined with on timer operation.

● Sleep timer

If the sleep timer is set, the room temperature is monitored and the operation is stopped automatically. If the operation mode or the set temperature is change after the sleep timer is set, the operation is continued according to the changed setting of the sleep timer from that time on.

- In the cooling operation mode

When the sleep timer is set, the setting temperature is increased 1°C. It increases the setting temperature another 1°C after 1 hour. After that, the setting temperature is not changed and the operation is stopped at the setting time.

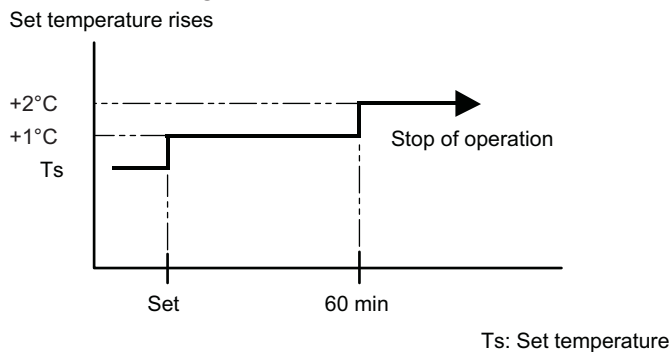

- In the heating operation mode

When the sleep timer is set, the setting temperature is decreased 1°C. It decreases the setting temperature another 1°C every 30 minutes. Upon lowering 4°C, the setting temperature is not changed and the operation is stopped at the setting time.

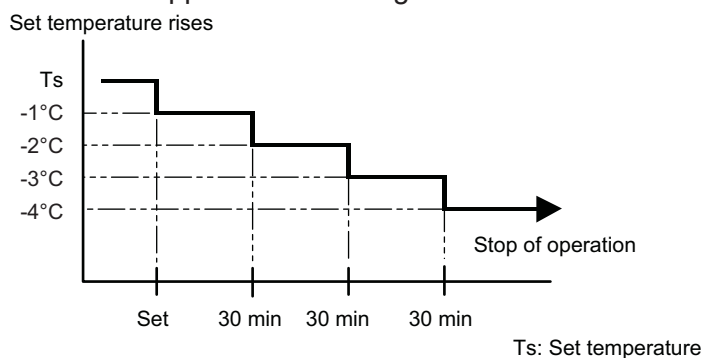

● Weekly timer

On and off timer can be combined, and up to 4 reservations per day and 28 reservations per week. Before setting the program, set the week and time of the air conditioner at first. If the week and time are not set, the weekly timer will not operate correctly at the setting time.

5-2. Wired remote control

On/Off timer	Program timer	Sleep timer	Weekly timer	Temperature Setback Timer
○	○	○	○	○

■ On/Off timer

- Off timer: When the clock reaches the set timer, the air conditioner will be turned off.

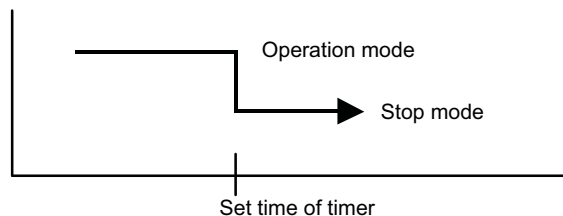

- On timer: When the clock reaches the set timer, the air conditioner will be turned on.

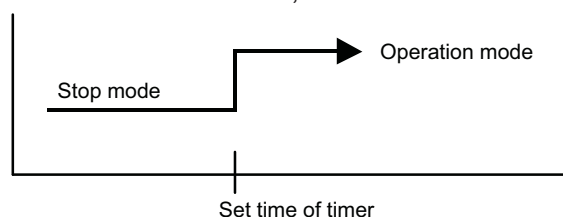

■ Program timer

- The program timer allows the off timer and the on timer to be used in combination one time.

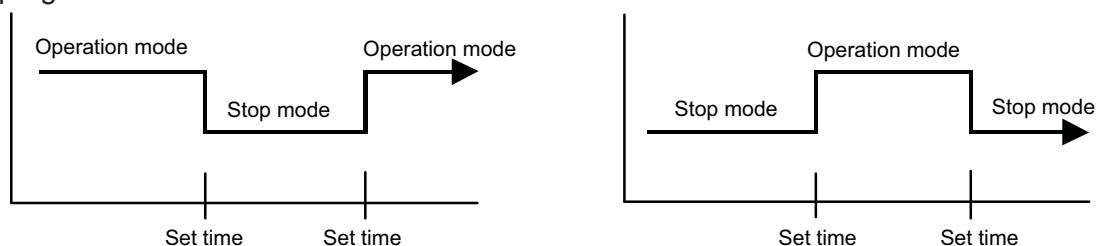

- Operation will start from the timer setting (either off timer and on timer) whichever is closest to the clock current timer setting. The order of operations is indicated by the allow in the remote controller screen.
- Sleep timer operation cannot be combined with on timer operation.

■ Sleep timer

If the sleep timer is set, the room temperature is monitored and the operation is stopped automatically. If the operation mode or the set temperature is change after the sleep timer is set, the operation is continued according to the changed setting of the sleep timer from that time on.

- In the cooling operation mode

When the sleep timer is set, the setting temperature is increased 1°C. It increases the setting temperature another 1°C after 1 hour. After that, the setting temperature is not changed and the operation is stopped at the setting time.

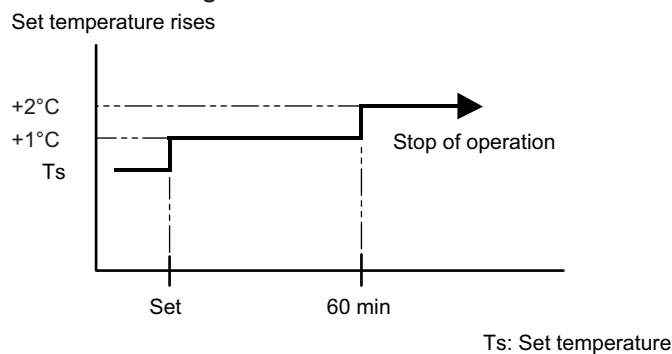

- In the heating operation mode

When the sleep timer is set, the setting temperature is decreased 1°C. It decreases the setting temperature another 1°C every 30 minutes. Upon lowering 4°C, the setting temperature is not changed and the operation is stopped at the setting time.

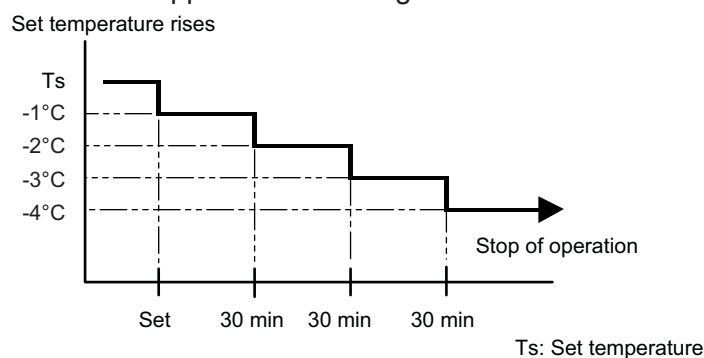

■ Weekly timer

On and off timer can be combined, and up to 4 reservations per day and 28 reservations per week. Before setting the program, set the week and time of the air conditioner at first. If the week and time are not set, the weekly timer will not operate correctly at the setting time.

■ Temperature Setback Timer

- The temperature setback timer only changes the set temperature for 7 days, it cannot be used to start or stop air conditioner operation.
- The temperature setback timer can be set to operate up to two times per day but only one temperature setting can be used.
- During COOLING/DRY mode, the air conditioner will operate at a minimum of 18°C even if the SET BACK temperature is set to 17°C or lower.

Case of Temperature Setback Timer on the Cooling operation. (Setting temperature: 22°C, SET BACK temperature: 26°C)

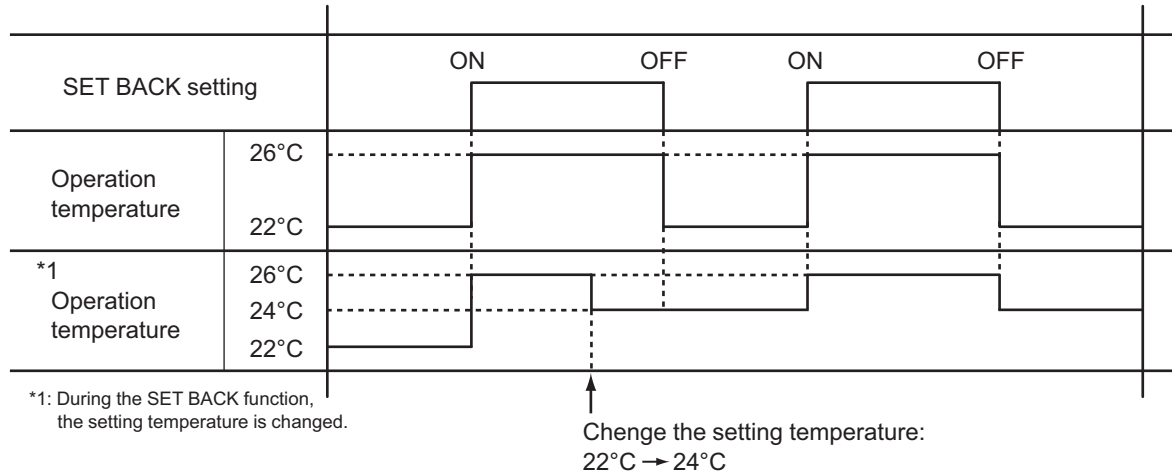

6. Defrost operation control

Tn: Outdoor unit heat exchanger temperature

Ta: Outdoor temperature

Tn10: Temperature at 10 minutes after compressor start

Tnb: Temperature before 5 minutes

• Triggering condition

The defrost operation starts when outdoor unit heat exchanger temperature sensor detects the temperature lower than the values shown below.

– 1st time defrosting after starting operation

Compressor integrating operation time	Less than 17 min.	17 to 57 min.	More than 57 min.
Condition	Does not operate	$T_n \leq -9\text{ }^\circ\text{C}$ and $T_n - T_a \geq 5\text{ deg}$	$T_n \leq -5\text{ }^\circ\text{C}$

– 2nd time and after

Compressor integrating operation time	Less than 40 min.	More than 40 min.
Condition	Does not operate	$T_n - T_{n10} < -5\text{ deg}$ ($T_n \leq -6\text{ }^\circ\text{C}$) $T_n - T_{nb} < -2\text{ deg}$ ($T_n \leq -6\text{ }^\circ\text{C}$) $T_n \leq -17\text{ }^\circ\text{C}$ ($T_a \geq -10\text{ }^\circ\text{C}$) $T_n \leq T_a - 7\text{ }^\circ\text{C}$ or $T_n \leq -20\text{ }^\circ\text{C}$ ($T_a < -10\text{ }^\circ\text{C}$)

– Integrating defrost (Constant monitoring)

Compressor integrating operation time	More than 240 min. (For long continuous operation)	More than 215 min. (For long continuous operation)	Less than 10 min.* (For intermittent operation)
Condition	$T_n \leq -3\text{ }^\circ\text{C}$	$T_n \leq -5\text{ }^\circ\text{C}$	Count of the compressor off: 40 times

*: If the compressor continuous operation time is less than 10 minutes, the number of the compressor off is counted. If any defrost operated, the compressor off count is cleared.

• Release condition

Depending on the triggering condition, different release conditions apply.

– Normal defrost operation

The defrost operation is released when either one of the conditions below is satisfied.

Outdoor unit heat exchanger temperature (after 1 minute or later since compressor start)	07/09 model	16°C or more ($T_a \leq 1\text{ }^\circ\text{C}$)
	12/14 model	13°C or more ($T_a \leq 1\text{ }^\circ\text{C}$)
Compressor operation time	15 minutes	

– Integrating defrost (constant monitoring)

The defrost operation is released when either one of the conditions below is satisfied.

Outdoor unit heat exchanger temperature (after 1 minute or later since compressor start)	07/09 model	16°C or more
	12/14 model	13°C or more
Compressor operation time	15 minutes	

6-1. Defrost operation in heating operation stopped

If the outdoor unit is frosted when stopping the heating operation, it stops after performing the automatic defrosting operation.

In this time, if the indoor unit operation lamp flashes slowly (6 sec on/2 sec off), the outdoor unit allow the heat exchanger to defrost, and then stop.

• Triggering condition

When all of the following conditions are satisfied in heating operation

- Compressor operation integrating time: 30 minutes or more
- Compressor continuous operation time: 10 minutes or more
- Outdoor unit heat exchanger temperature: -4°C or less

• Release condition

Depending on the triggering condition, different release conditions apply.

– Normal defrost operation

The defrost operation is released when either one of the conditions below is satisfied.

Outdoor unit heat exchanger temperature (after 1 minute or later since compressor start)	07/09 model	16°C or more ($T_a \leq 1^\circ\text{C}$)
	12/14 model	13°C or more ($T_a \leq 1^\circ\text{C}$)
Compressor operation time	15 minutes	

– Integrating defrost (constant monitoring)

The defrost operation is released when either one of the conditions below is satisfied.

Outdoor unit heat exchanger temperature (after 1 minute or later since compressor start)	07/09 model	16°C or more
	12/14 model	13°C or more
Compressor operation time	15 minutes	

7. Various control

7-1. Auto restart

When the power was interrupted by a power failure etc. during operation, the operation contents at that time are memorized and when the power is recovered, operation is automatically started with the memorized operation contents.

Operation contents memorized when the power is interrupted
Operation mode
Setting temperature
Fan mode setting
Timer mode and set time (set by wireless remote controller)
Airflow direction setting
Swing
ECONOMY operation
10 °C HEAT operation
Outdoor low noise operation
Remote control setting
WLAN LED setting

7-2. MANUAL AUTO operation

When the wireless remote controller is lost or battery power dissipated, this function will work without the remote controller.

When MANUAL AUTO button is pressed more than 3 seconds and less than 10 seconds, MANUAL AUTO operation starts as shown in the table below. To stop operation, press the MANUAL AUTO button for 3 seconds.

Operation mode	Auto changeover
Fan mode	AUTO
Timer mode	Continuous (no timer setting available)
Setting temperature	24°C
Horizontal louver setting	Standard
Vertical louver setting	According to memory position
SWING	Off
ECONOMY	Off
Human sensor	Off

7-3. Forced cooling operation

The outdoor unit may not operate depending on the room temperature.

When FORCED COOLING OPERATION button is pressed more than 10 seconds, forced cooling operation starts as shown in the table below.

Operation mode	Cooling
Fan mode	HIGH
Timer mode	Continuous (no timer setting available)
Setting temperature	24°C
Horizontal louver setting	Standard
Vertical louver setting	According to memory position
SWING	Off
ECONOMY	Off
Human sensor	Off

- During the forced cooling operation, it operates regardless of room temperature sensor.
- The operation indicator lamp and the timer indicator lamp blink simultaneously during the forced cooling operation.
They blink for 1 second ON and 1 second OFF on both the operation indicator lamp and the timer indicator lamp (same as test operation).

By performing one of the following action, test operation will be canceled:

- Pressing the remote controller START/STOP button
- Pressing FORCED COOLING OPERATION button for 3 seconds
- 60 minutes passed after starting forced cooling operation

NOTE: When HEAT operation is selected on the remote controller during forced cooling operation, heating test run will begin in about 3 minutes.

7-4. 10 °C HEAT operation

10 °C HEAT operation can start via the remote controller. The starting operation may vary between the remote controller models.

Operation mode	Heating
Setting temperature	10°C
Fan mode	AUTO
LED display	Economy
Defrost operation	Operate as normal

7-5. ECONOMY operation

The ECONOMY operation can start via the remote controller. The starting operation may vary between the remote controller models.

The ECONOMY operation is almost the same operation as below settings.

Mode	Cooling/Dry	Heating
Target temperature	Setting temperature +1°C	Setting temperature -1°C

7-6. POWERFUL operation

The POWERFUL operation can start via the remote controller. The starting operation may vary between the remote controller models.

The indoor unit and outdoor unit operate at maximum power as shown in the table below.

Rotation number of compressor		Maximum
Fan mode		POWERFUL
Vertical airflow direction louver setting	Cooling	3
	Dry	
	Heating	6

Release condition:

- Cooling/Dry
Room temperature \leq Setting temperature -0.5°C or Operation time has passed 20 minutes.
- Heating
Room temperature \geq Setting temperature $+0.5^{\circ}\text{C}$ or Operation time has passed 20 minutes.

7-7. Fresh air control

The fan motor for Fresh Air is operated in synchronization with the indoor fan operation as below.

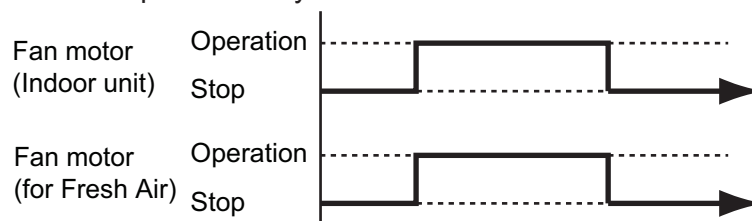

7-8. Compressor preheating operation

Compressor preheating operation prevents the damage caused by the refrigerant in the compressor from soaking into the oil. By preheating the compressor, warm airflow is quickly discharged when the operation is started.

- **Triggering condition**
 - 30 minutes after compressor stopped.
 - Outdoor unit heat exchanger temperature (T_n)

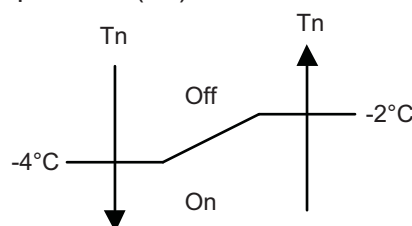

When the jumper wire (J600) is disconnected:

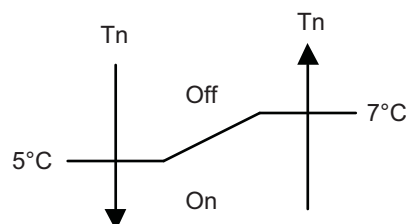

7-9. External electrical heater control

The external electrical heater is operated as below.

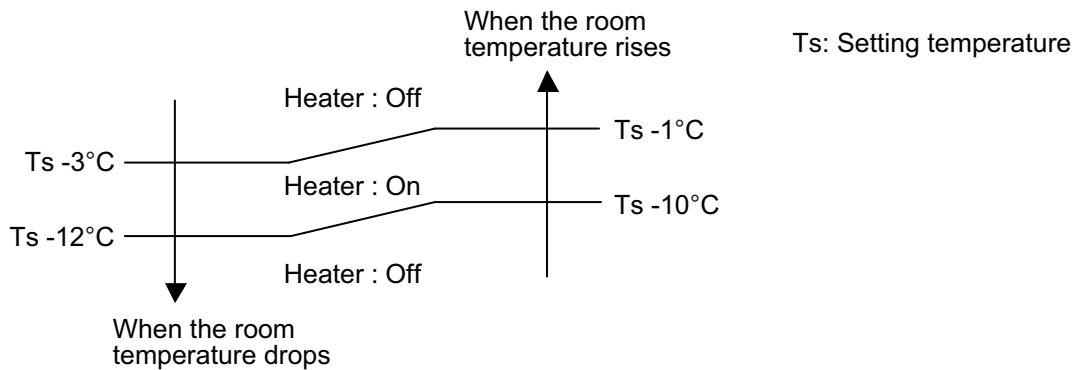

NOTES:

- When the compressor stop, external electric heater is off.
- It operates only in heating mode and when the indoor fan operates. (However, S-LOW is excluded.)

7-10. Electronic expansion valve control

The most proper opening of the electronic expansion valve is calculated and controlled under the present operating condition based on the table below.

- **Models: AOEH07KJCA and AOEH09KJCA**

Operation mode		Pulse range
Cooling/dry mode		Between 10 and 480 pulses
Heating mode	$0^{\circ}\text{C} \leq \text{Outdoor temp.}$	Between 10 and 480 pulses
	$\text{Outdoor temp.} < 0^{\circ}\text{C}$	Between 52 and 480 pulses

- **Models: AOEH12KJCA and AOEH14KJCA**

Operation mode		Pulse range
Cooling/dry mode		Between 10 and 480 pulses
Heating mode	$0^{\circ}\text{C} \leq \text{Outdoor temp.}$	Between 10 and 480 pulses
	$\text{Outdoor temp.} < 0^{\circ}\text{C}$	Between 50 and 480 pulses

NOTE: At the time of supplying the power to the outdoor unit, the initialization of the electronic expansion valve is operated (528 pulses are input to the closing direction).

7-11. Prevention to restart for 3 minutes (3 minutes st)

When the compressor fails to start for the number of times below, it does not enter operation status for 3 minutes.

Retry number	5
Retry set number	3

When the compressor fails to start in the retry set number above, the compressor is stopped.

7-12. 4-way valve control

- If heating mode is selected at the compressor start, 4-way valve is energized for heating.
- When the air conditioner is switched between cooling and heating mode, compressor is stopped, and the 4-way valve is switched when the 3 minutes passes and the compressor is started.

7-13. Human sensor for energy saving

If no one enters the room for approximately 20 minutes, the set temperature is automatically controlled. (When someone comes back into the room, the human sensor detect this, and automatically revert to the original settings.)

Operation mode	Operation details (If there is no one in the room for a while)
Cool/Dry	The setting temperature is increased by maximum 2°C. (Maximum setting temperature: 30°C)
Heat	The setting temperature is decreased by maximum 4°C. (Minimum setting temperature: 16°C)
Auto	Energy saving function is performed automatically for the selected mode (cool/heat/dry).

- Application range:

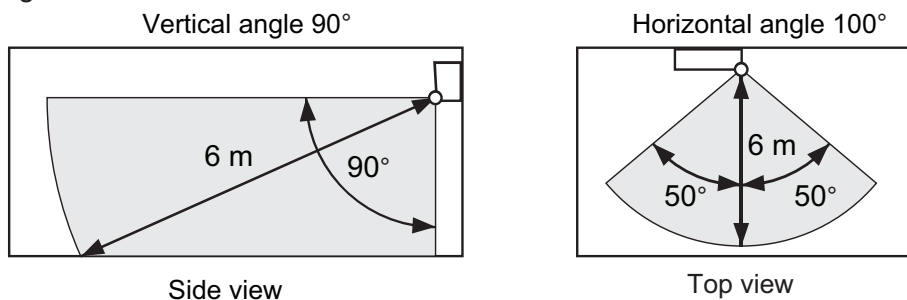

Energy saving function may not work when the room temperature is very different from the temperature defined in the temperature setting, such as when immediately after starting the operation.

- Details about detection with the human sensor:
The human sensor detects whether there are people in the room by looking for movement by people in the room.

7-14. Outdoor unit low noise operation

The outdoor unit low noise operation can start via the remote controller. The starting operation may vary between the remote controller models.

This operation stops the PFC control, and changes the current value.

Operation mode	Current	
	Trigger condition	Release condition
Cooling/Dry mode	1.9 A	1.4 A
Heating mode		

7-15. Heat Clean operation

The indoor unit's heat exchanger heats the condensed water to 55°C and maintains that temperature or higher for 10 minutes to keep the heat exchanger clean.

■ Operation flow

The indoor unit starts the Heat Clean operation when the indoor unit receives a signal from the remote controller to start the Heat Clean operation. The indoor unit performs the Heat Clean operation during the unit's operation stops, as shown in the following flow.

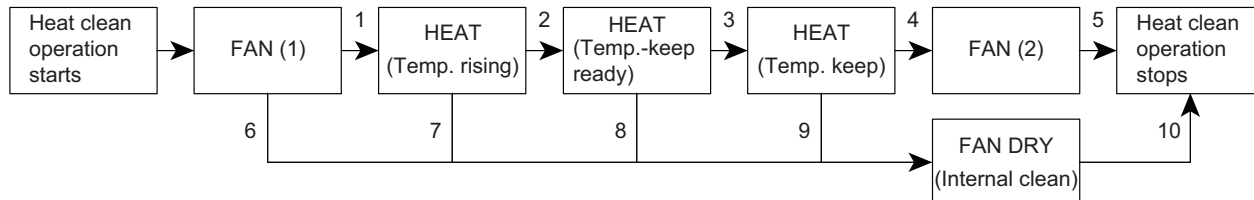

The transition between each process in this flow (1 to 10) is subject to the following conditions.

1. The following time elapsed after the start of the FAN (1) operation.
 - 50 minutes
2. The indoor unit thermistor (Heat exchanger temp.) detects 50°C or more.
3. The indoor unit thermistor (Heat exchanger temp.) detects 55°C or more.
4. 600 seconds elapsed after since the indoor unit thermistor (Heat exchanger temp.) detects 55°C or more.

NOTE: The indoor unit does not stop or reset the 600-second count even if the indoor unit thermistor (Heat exchanger temp.) detects less than 55°C.

5. The following time elapsed after the start of the FAN (2) operation.
 - 0 minutes
6. The thermistor (Outdoor temp.) detects 43°C or more when the following time elapsed after the start of the FAN (1) operation.
 - 49 minutes
7. Either of the following conditions are met.
 - 600 seconds elapsed after the start of the indoor unit's HEAT operation.
 - 60 seconds elapsed after the indoor unit's HEAT operation started, and the compressor stopped.
8. Either of the following conditions are met.
 - 600 seconds elapsed after the start of the indoor unit's HEAT operation.
 - 60 seconds elapsed after the indoor unit's HEAT operation started, and the compressor stopped.
9. Either of the following conditions are met.
 - The indoor unit thermistor (Heat exchanger temp.) detects 59°C or more.
 - 60 seconds elapsed after the indoor unit's HEAT operation started, and the compressor stopped.
10. The following time elapsed after the start of the FAN DRY operation.
 - 50 minutes

NOTES:

- The timing at which the indoor unit starts the Heat Clean operation varies depending on the operating status of the indoor unit when it receives the Heat Clean operation start signal.
 - The indoor unit cancels the current operation and starts the Heat Clean operation when it receives the signal under the following conditions.
The indoor unit cancels the timer setting when it starts the Heat Clean operation.
 - In operation (COOL, HEAT, DRY, FAN, AUTO, and 10 °C HEAT)
 - On/Off Timer standby or Sleep Timer standby
 The indoor unit stops after finishing the Heat Clean operation.
 - The indoor unit completes the current operation and starts the Heat Clean operation when it receives the signal under the following conditions.
 - Defrosting operation
(including the defrosting operation in the heating operation stopped)
- The indoor unit cancels the Heat Clean operation when it receives the following signals during the Heat Clean operation, and operates according to the signal.
 - Start operation signal through:
 - IR signal
 - Nonpolar 2-wired communication
 - External communication
 - General-purpose input
 - Stop operation signal through:
 - IR signal
 - Nonpolar 2-wired communication
 - External communication
 - General-purpose input
 - Switch of the unit
 - Weekly timer
- Heat Clean operation is not available in Group Control.

■ Rotation number of the compressor and indoor unit fan

- Models: ASEH07KJCAL, ASEH09KJCAL, ASEH07KJCALB, and ASEH09KJCALB

Operation	Condition		Rotation number (Unit: rpm)	
			Compressor	Indoor unit fan
FAN (1)			0	670
HEAT (Temp. rising)	Thermistor (Room temp.) detects less than 27°C		46	750
	Thermistor (Room temp.) detects 27°C or more			830
	Elapsed time after HEAT operation started (Unit: second)	240		560
		300		510
		360	460	
420		51	—	
HEAT (Temp.-keep ready)			Same as HEAT (Temp. rising)	The rotation number depends on the indoor unit heat exchanger temperature.
HEAT (Temp. keep)			—	<ul style="list-style-type: none"> • Maximum: 970 • Minimum: 380
FAN (2)			0	670
FAN DRY (Internal clean)			0	670

- Models: ASEH12KJCAL, ASEH14KJCAL, ASEH12KJCALB, and ASEH14KJCALB

Operation	Condition		Rotation number (Unit: rpm)	
			Compressor	Indoor unit fan
FAN (1)			0	710
HEAT (Temp. rising)	Thermistor (Room temp.) detects less than 27°C		46	900
	Thermistor (Room temp.) detects 27°C or more			900
	Elapsed time after HEAT operation started (Unit: second)	240		690
		300		640
		360	590	
420		54	—	
HEAT (Temp.-keep ready)			Same as HEAT (Temp. rising)	The rotation number depends on the indoor unit heat exchanger temperature.
HEAT (Temp. keep)			—	<ul style="list-style-type: none"> • Maximum: 990 • Minimum: 420
FAN (2)			0	710
FAN DRY (Internal clean)			0	710

7-16. Unit status monitoring and the detected value indication

The wired remote controller can monitor the indoor and outdoor units' status and display the detected result as a relevant ID.

For details of the display method, refer to the Chapter of "Display Sensor Values" in the *Installation Manual* of Wired Remote Controller (Touch Panel).

The status can be monitored and displayed on the wired remote controller by assigning an arbitrary ID. For available ID list, refer to the table below.

NOTE: Operating time for each part cannot be reset when the part is replaced. Take notes of the operating time before replacing to count the operating time of the replaced part.

Available Sensor ID				
Sensor ID	Item	Unit	Remarks	
00: Indoor unit				
00	000	Suction temp.	01: °C or °F	
00	001	Room temp.	01: °C or °F	When the wired remote controller thermistor is enabled, temperature of the wired remote controller thermistor is displayed.
00	002	Wired remote controller detected temp.	01: °C or °F	
00	006	Heat exchanger middle temp.	01: °C or °F	
00	020	Fan rotation number	03: rpm	
00	080	Indoor unit total energized hours	11: h	
00	081	Total filtering hours	11: h	
00	082	Indoor unit fan total operation hours	11: h	
00	095	Presence or absence detected by human sensor	00: —	0: Absence, 1: Presence —: Human sensor error or No human sensor
00	140	Operation or Stop (External input)	00: —	0: Off, 1: On —: When the function setting 46 is not set NOTE: Available only for external input port of the indoor unit
00	142	Forced stop (External input)	00: —	0: Off, 1: On —: When the function setting 46 is not set NOTE: Available only for external input port of the indoor unit
00	143	Operation or Stop 2 (External input)	00: —	0: Off, 1: On —: When the function setting 46 is not set NOTE: Available only for external input port of the indoor unit
00	155	Operation or Stop On/Off (External output)	00: —	0: Off, 1: On NOTE: The value is output even if the function setting or rotary switch is not set.
00	156	Error On/Off (External output)	00: —	0: Off, 1: On NOTE: The value is output even if the function setting or rotary switch is not set.
00	157	Indoor unit fan interlocking On/Off (External output)	00: —	0: Off, 1: On NOTE: The value is output even if the function setting or rotary switch is not set.

Available Sensor ID				
Sensor ID		Item	Unit	Remarks
00	158	Cooling thermostat On/Off (External output)	00: —	0: Off, 1: On NOTE: The value is output even if the function setting or rotary switch is not set.
00	159	Requested cooling strength On/Off (External output)	00: —	0: Off, 1: On NOTE: The value is output even if the function setting or rotary switch is not set.
00	160	External heater On/Off (External output)	00: —	0: Off, 1: On NOTE: The value is output even if the function setting or rotary switch is not set.
00	161	Heating operation status (External output)	00: —	0: Off, 1: On NOTE: The value is output even if the function setting or rotary switch is not set.
00	162	External output command by remote controller (External output)	00: —	0: Off, 1: On NOTE: The value is output even if the function setting or rotary switch is not set.
01: Outdoor unit				
01	000	Outdoor temp.	01: °C or °F	
01	001	Discharge temp.	01: °C or °F	
01	003	Heat exchanger middle temp.	01: °C or °F	
01	004	Heat exchanger outlet temp.	01: °C or °F	
01	007	Compressor temp.	01: °C or °F	
01	050	Fan 1 rotation number	03: rpm	
01	055	Compressor rotation number	04: rps	
01	060	Expansion valve (Upstream during heating)	05: pls	
01	080	4-way valve output status	07: Cooling/ Heating	0: Cooling, 1: Heating
01	100	Operating current	09: A	
01	110	Outdoor unit total power-on hours	11: h	
01	111	Compressor total heating operation hours	11: h	
01	112	Compressor total cooling operation hours	11: h	
01	113	Compressor total operation hours	11: h	
01	114	Outdoor unit fan 1 total operation hours	11: h	

8. Various protections

8-1. Discharge gas temperature over-rise prevention control

The discharge gas temperature sensor (discharge thermistor: outdoor unit side) detects the discharge gas temperature.

- When the discharge temperature becomes higher than the trigger condition, the rotation number of compressor is decreased as the table below, and it continues to decrease until the discharge temperature becomes lower than the trigger condition.
- When the discharge temperature becomes lower than the release condition, control of compressor rotation number is released.
- When the discharge temperature becomes higher than the compressor protection temperature, the compressor is stopped and the indoor unit indicator lamp starts blinking.

Trigger condition	104°C
Rotation number of compressor	-20 rps/120 seconds
Release condition	101°C
Compressor protection temperature	110°C

8-2. Anti-freezing control (cooling and dry mode)

The rotation number of compressor is decrease in cooling and dry mode when the indoor unit heat exchanger temperature sensor detects the temperature lower than the trigger condition.

When the indoor unit heat exchanger temperature reaches release condition, the anti-freezing control is stopped.

Trigger condition	4°C	
Release condition	Outdoor temp. $\geq 10^{\circ}\text{C}^{*1}$	7°C
	Outdoor temp. $\geq 12^{\circ}\text{C}^{*2}$	
	Outdoor temp. $< 10^{\circ}\text{C}^{*1}$	13°C
	Outdoor temp. $< 12^{\circ}\text{C}^{*2}$	

*1: During the outdoor temperature dropping

*2: During the outdoor temperature rising

8-3. Current release control

The rotation number of compressor is controlled so that the outdoor unit input current does not exceeds current limit value set according to the outdoor temperature.

The rotation number of compressor returns according to the operation mode, when the current becomes lower than the release value.

■ Model: AOEH07KJCA

Operation mode	Outdoor temp. (Ta)	Trigger condition	Release condition
Cooling	$50^{\circ}\text{C} \leq \text{Ta}$	4.0 A	3.5 A
	$46^{\circ}\text{C} \leq \text{Ta} < 50^{\circ}\text{C}$	4.0 A	3.5 A
	$38^{\circ}\text{C} \leq \text{Ta} < 46^{\circ}\text{C}$	4.0 A	3.5 A
	$12^{\circ}\text{C} \leq \text{Ta} < 38^{\circ}\text{C}$	4.0 A	3.5 A
	$2^{\circ}\text{C} \leq \text{Ta} < 12^{\circ}\text{C}$	6.0 A	5.5 A
	$\text{Ta} < 2^{\circ}\text{C}$	6.0 A	5.5 A
Heating	$17^{\circ}\text{C} \leq \text{Ta}$	4.5 A	4.0 A
	$12^{\circ}\text{C} \leq \text{Ta} < 17^{\circ}\text{C}$	4.5 A	4.0 A
	$5^{\circ}\text{C} \leq \text{Ta} < 12^{\circ}\text{C}$	5.0 A	4.5 A
	$\text{Ta} < 5^{\circ}\text{C}$	8.5 A	8.0 A

■ Model: AOEH09KJCA

Operation mode	Outdoor temp. (Ta)	Trigger condition	Release condition
Cooling	$50^{\circ}\text{C} \leq \text{Ta}$	4.0 A	3.5 A
	$46^{\circ}\text{C} \leq \text{Ta} < 50^{\circ}\text{C}$	4.0 A	3.5 A
	$38^{\circ}\text{C} \leq \text{Ta} < 46^{\circ}\text{C}$	4.5 A	4.0 A
	$12^{\circ}\text{C} \leq \text{Ta} < 38^{\circ}\text{C}$	4.5 A	4.0 A
	$2^{\circ}\text{C} \leq \text{Ta} < 12^{\circ}\text{C}$	6.0 A	5.5 A
	$\text{Ta} < 2^{\circ}\text{C}$	6.0 A	5.5 A
Heating	$17^{\circ}\text{C} \leq \text{Ta}$	5.5 A	5.0 A
	$12^{\circ}\text{C} \leq \text{Ta} < 17^{\circ}\text{C}$	6.5 A	6.0 A
	$5^{\circ}\text{C} \leq \text{Ta} < 12^{\circ}\text{C}$	6.5 A	6.0 A
	$\text{Ta} < 5^{\circ}\text{C}$	8.5 A	8.0 A

■ Model: AOEH12KJCA

Operation mode	Outdoor temp. (Ta)	Trigger condition	Release condition
Cooling	$50^{\circ}\text{C} \leq \text{Ta}$	4.0 A	3.5 A
	$46^{\circ}\text{C} \leq \text{Ta} < 50^{\circ}\text{C}$	4.0 A	3.5 A
	$38^{\circ}\text{C} \leq \text{Ta} < 46^{\circ}\text{C}$	5.0 A	4.5 A
	$12^{\circ}\text{C} \leq \text{Ta} < 38^{\circ}\text{C}$	6.0 A	5.5 A
	$2^{\circ}\text{C} \leq \text{Ta} < 12^{\circ}\text{C}$	6.0 A	5.5 A
	$\text{Ta} < 2^{\circ}\text{C}$	6.0 A	5.5 A
Heating	$17^{\circ}\text{C} \leq \text{Ta}$	5.5 A	5.0 A
	$12^{\circ}\text{C} \leq \text{Ta} < 17^{\circ}\text{C}$	7.0 A	6.5 A
	$5^{\circ}\text{C} \leq \text{Ta} < 12^{\circ}\text{C}$	7.5 A	7.0 A
	$\text{Ta} < 5^{\circ}\text{C}$	8.5 A	8.0 A

■ Model: AOEH14KJCA

Operation mode	Outdoor temp. (Ta)	Trigger condition	Release condition
Cooling	$50^{\circ}\text{C} \leq \text{Ta}$	4.0 A	3.5 A
	$46^{\circ}\text{C} \leq \text{Ta} < 50^{\circ}\text{C}$	4.0 A	3.5 A
	$38^{\circ}\text{C} \leq \text{Ta} < 46^{\circ}\text{C}$	5.0 A	4.5 A
	$12^{\circ}\text{C} \leq \text{Ta} < 38^{\circ}\text{C}$	6.5 A	6.0 A
	$2^{\circ}\text{C} \leq \text{Ta} < 12^{\circ}\text{C}$	6.5 A	6.0 A
	$\text{Ta} < 2^{\circ}\text{C}$	6.5 A	6.0 A
Heating	$17^{\circ}\text{C} \leq \text{Ta}$	5.5 A	5.0 A
	$12^{\circ}\text{C} \leq \text{Ta} < 17^{\circ}\text{C}$	7.0 A	6.5 A
	$5^{\circ}\text{C} \leq \text{Ta} < 12^{\circ}\text{C}$	8.5 A	8.0 A
	$\text{Ta} < 5^{\circ}\text{C}$	8.5 A	8.0 A

8-4. Low outdoor temperature protection

When the outdoor temperature sensor detects lower than the trigger condition below, the compressor is stopped.

Operation mode	Cooling/Dry
Trigger condition	-15°C
Release condition	-10°C

8-5. High temperature and high pressure release control

The compressor is controlled as follows.

- **Cooling mode**

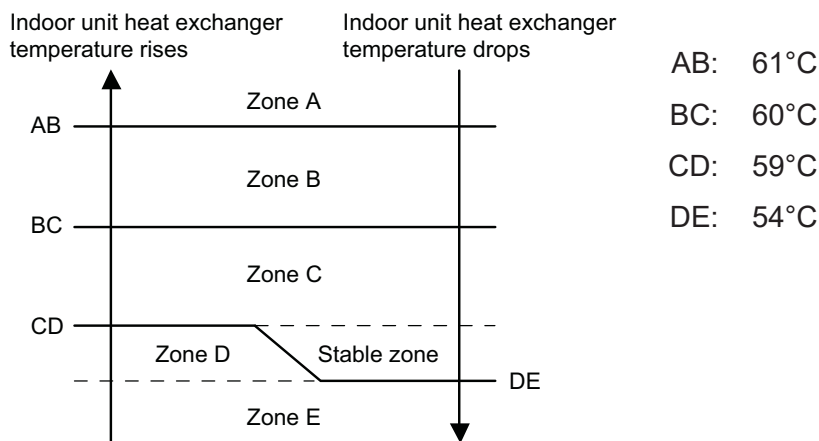

Zone	Operation	
Zone A	Compressor is stopped.	
Zone B	The rotation number of compressor is decreased.	-30 rps/30 sec.
Zone C		-5 rps/60 sec.
Zone D	The protection is released and the operation is returned to normal mode.	
Zone E		

- **Heating mode**

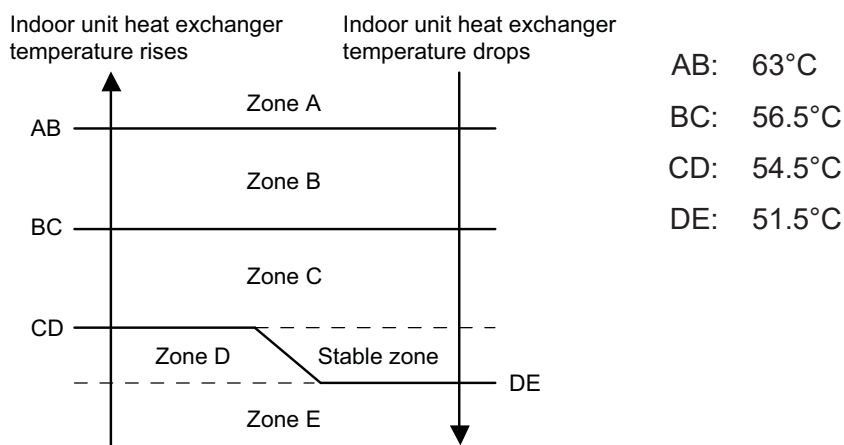

Zone	Operation	
Zone A	Compressor is stopped.	
Zone B	The rotation number of compressor is decreased.	-25 rps/120 sec.
Zone C		-3 rps/60 sec.
Zone D	The protection is released and the operation is returned to normal mode.	
Zone E		

5. FIELD WORKING

CONTENTS

5. FIELD WORKING

1. Function settings	05-1
1-1. Function settings by using remote controller	05-1
1-2. Custom code setting for wireless remote controller	05-7
2. External input and output	05-8
2-1. External input.....	05-9
2-2. External output	05-12
2-3. Setting of external input and output	05-14
2-4. Details of control input function.....	05-15
2-5. Details of control output function	05-19

1. Function settings

To adjust the functions of this product according to the installation environment, various types of function settings are available.

NOTE: Incorrect settings can cause a product malfunction.

1-1. Function settings by using remote controller

Some function settings can be changed on the remote controller. After confirming the setting procedure and the content of each function setting, select appropriate functions for your installation environment.

■ Setting procedure by using wireless remote controller

The function number and the associated setting value are displayed on the LCD of the remote controller. Follow the instructions written in the local setup procedure supplied with the remote controller, and select appropriate setting according to the installation environment.

Before connecting the power supply of the indoor unit, reconfirm following items:



- Cover for the electrical enclosure on the outdoor unit is in place.
- There is no wiring mistake.
- Piping air tightness test and vacuuming have been performed firmly.
- All the necessary wiring work for outdoor unit has been finished.

After reconfirming the items listed above, connect the power supply of the indoor unit.











NOTES:

- Settings will not be changed if invalid numbers or setting values are selected.
- When optional wired remote controller is used, refer to the installation manual enclosed with the remote controller.

Entering function setting mode:

While pressing the  button and  button simultaneously, press the RESET button to enter the function setting mode.

Selecting the function number and setting value:

1. Press the / or / buttons to select the function number.
2. Press the MODE button to proceed to value setting. To return the function number selection, press the MODE button again.
3. Press the / or / buttons to select the setting value.
4. Press the  button once. Confirm that you hear the beep.
5. Press the START/STOP() button to fix the function setting. Confirm that you hear the beep.
6. Press the RESET button to end the function setting mode.
7. After completing the function setting, be sure to disconnect the power supply and then reconnect it.

Function number
Setting value

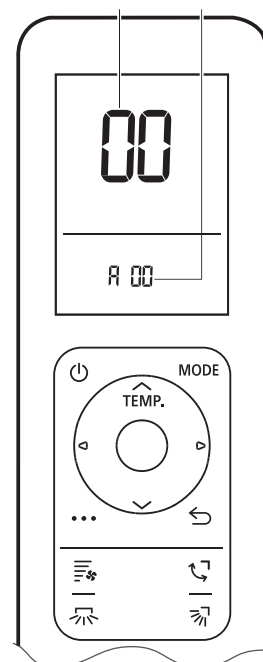

CAUTION

After disconnecting the power supply, wait 30 seconds or more before reconnecting it. The function setting will not become active unless the power supply is disconnected and then reconnected.

■ Contents of function setting

Each function setting listed in this section is adjustable in accordance with the installation environment.

NOTE: Setting will not be changed if invalid numbers or setting values are selected.

● Function setting list

	Function no.	Functions
1)	11	Filter sign
2)	30/31	Room temperature control for indoor unit sensor
3)	35/36	Room temperature control for wired remote controller sensor
4)	40	Auto restart
5)	42	Room temperature sensor switching
6)	44	Remote controller custom code
7)	46	External input control
8)	48	Room temperature sensor switching (Aux.)
9)	49	Indoor unit fan control for energy saving for cooling
10)	60	Switching functions for external output terminal
11)	84	Wired Remote Controller function extension setting

1) Filter sign

Select appropriate intervals for displaying the filter sign on the indoor unit according to the estimated amount of dust in the air of the room.

If the indication is not required, select "No indication" (03).

Function number	Setting value	Setting description	Factory setting
11	00	Standard (400 hours)	
	01	Long interval (1,000 hours)	
	02	Short interval (200 hours)	
	03	No indication	◆

2) Room temperature control for indoor unit sensor

Depending on the installed environment, correction of the room temperature sensor may be required. Select the appropriate control setting according to the installed environment.

The temperature of the room temperature sensor is corrected as follows:

Corrected temp. = Temp. of the room temp. sensor - Correction temp. value

Example of correction:

When the temperature of the room temp. sensor is 26°C and the setting value is "03" (-1.0°C), corrected temp. will be 27°C (26°C - [-1.0°C]).

The temperature correction values show the difference from the Standard setting "00" (manufacturer's recommended value).

Function number		Setting value	Setting description	Factory setting	
30 (For cooling)	31 (For heating)	00	Standard setting	◆	
		01	No correction 0.0°C		
		02	-0.5°C	More cooling Less heating	
		03	-1.0°C		
		04	-1.5°C		
		05	-2.0°C		
		06	-2.5°C		
		07	-3.0°C		
		08	-3.5°C		
		09	-4.0°C		
		10	+0.5°C	Less cooling More heating	
		11	+1.0°C		
		12	+1.5°C		
		13	+2.0°C		
		14	+2.5°C		
		15	+3.0°C		
		16	+3.5°C		
17	+4.0°C				

3) Room temperature control for wired remote controller sensor

Depending on the installed environment, correction of the wire remote temperature sensor may be required. Select the appropriate control setting according to the installed environment.

To change this setting, set Function 42 to Both "01".

Ensure that the Thermo Sensor icon is displayed on the remote controller screen.

Function number		Setting value	Setting description	Factory setting	
35 (For cooling)	36 (For heating)	00	Standard setting	◆	
		01	No correction 0.0°C		
		02	-0.5°C	More cooling Less heating	
		03	-1.0°C		
		04	-1.5°C		
		05	-2.0°C		
		06	-2.5°C		
		07	-3.0°C		
		08	-3.5°C		
		09	-4.0°C		
		10	+0.5°C	Less cooling More heating	
		11	+1.0°C		
		12	+1.5°C		
		13	+2.0°C		
		14	+2.5°C		
		15	+3.0°C		
		16	+3.5°C		
17	+4.0°C				

4) Auto restart

Enables or disables automatic restart after a power interruption.

Function number	Setting value	Setting description	Factory setting
40	00	Enable	◆
	01	Disable	

NOTE: Auto restart is an emergency function such as for power outage etc. Do not attempt to use this function in normal operation. Be sure to operate the unit by remote controller or external device.

5) Room temperature sensor switching

(Only for wired remote controller)

When using the wired remote controller temperature sensor, change the setting to "Both" (01).

Function number	Setting value	Setting description	Factory setting
42	00	Indoor unit	◆
	01	Both	

00: Sensor on the indoor unit is active.

01: Sensors on both indoor unit and wired remote controller are active.

NOTE: Remote controller sensor must be turned on by using the remote controller.

6) Remote controller custom code

(Only for wireless remote controller)

The indoor unit custom code can be changed. Select the appropriate custom code.

Function number	Setting value	Setting description	Factory setting
44	00	A	◆
	01	B	
	02	C	
	03	D	

7) External input control

“Operation/Stop” mode or “Forced stop” mode can be selected.

Function number	Setting value	Setting description	Factory setting
46	00	Operation/Stop mode 1 (Remote controller enabled)	◆
	01	(Setting prohibited)	
	02	Forced stop mode	
	03	Operation/Stop mode 2 (Remote controller disabled)	

8) Room temperature sensor switching (Aux.)

To use the temperature sensor on the wired remote controller only, change the setting to “Wired remote controller” (01).

This function will only work if the function setting 42 is set at “Both” (01).

When the setting value is set to “Both” (00), more suitable control of the room temperature is possible by setting function setting 30 and 31 too.

Function number	Setting value	Setting description	Factory setting
48	00	Both	◆
	01	Wired remote controller	

9) Indoor unit fan control for energy saving for cooling

Enables or disables the power-saving function by controlling the indoor unit fan rotation when the outdoor unit is stopped during cooling operation.

Function number	Setting value	Setting description	Factory setting
49	00	Disable	
	01	Enable	
	02	Remote controller	◆

00: When the outdoor unit is stopped, the indoor unit fan operates continuously following the setting on the remote controller.

01: When the outdoor unit is stopped, the indoor unit fan operates intermittently at a very low speed.

02: Enable or disable this function by remote controller setting.

NOTE: Set to “00” or “01” when connecting a remote controller that cannot set the Fan control for energy saving function or connecting a network converter. To confirm if the remote controller has this setting, refer to the operating manual of each remote controller.

10) Switching functions for external output terminal

Functions of the external output terminal can be switched. For details, refer to “External input and output”.

Function number	Setting value	Setting description	Factory setting
60	00	Operation status	◆
	01—08	(Setting prohibited)	
	09	Error status	
	10	Indoor unit fan operation status	
	11	(Setting prohibited)	

11) Wired Remote Controller function extension setting

Enables the “POWERFUL”, “10 °C HEAT”, or “OUTDOOR LOW NOISE” operation when connecting the Wired Remote Controller (UTY-RVRY).

Function number	Setting value	Setting description	Factory setting
84	00	Disable	◆
	01	Enable	

- Refer to the operation manual of the air conditioner to check whether it supports each function.
- All indoor units must have the same setting value in a Group Control system.

1-2. Custom code setting for wireless remote controller

To interconnect the air conditioner and the wireless remote controller, assignment of the custom code for the wireless remote controller is required.

NOTE: Air conditioner cannot receive a signal if the air conditioner has not been set for the custom code.

When 2 or more air conditioners are installed in a room, and the remote controller is operating an air conditioner other than the one you wish to set, change the custom code of the remote controller to operate only the air conditioner you wish to set. (4 selections possible.)

Confirm the setting of the remote controller custom code and the function setting. If these do not match, the remote controller cannot be used to operate for the air conditioner.

1. Press the START/STOP (⏻) button until the indicators on the remote controller turn off.
2. Press the MODE button for at least 5 seconds to display the current custom code. (Initially set to A .)
3. Press the \wedge/\vee or $\triangleleft/\triangleright$ buttons to change the custom code between $\text{A} \rightarrow \text{b} \rightarrow \text{c} \rightarrow \text{d}$. Match the code on the display to the air conditioner custom code. (Initially set to A .)
4. Press the MODE button again to return to the clock display. The custom code will be changed.

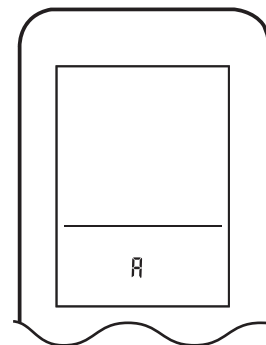

NOTES:

- If no button is pressed within 30 seconds after the custom code is displayed, the displayed custom code will be set.
- The air conditioner custom code is set to A prior to shipment. To change the custom code, contact your retailer.
- Depending on the remote controller, the custom code may return to A when replacing the batteries. In this case, reset the custom code as necessary.
- If you do not know the assigned code for the air conditioner, try each of the custom code ($\text{A} \rightarrow \text{b} \rightarrow \text{c} \rightarrow \text{d}$) until you find the code which operates the air conditioner.

2. External input and output

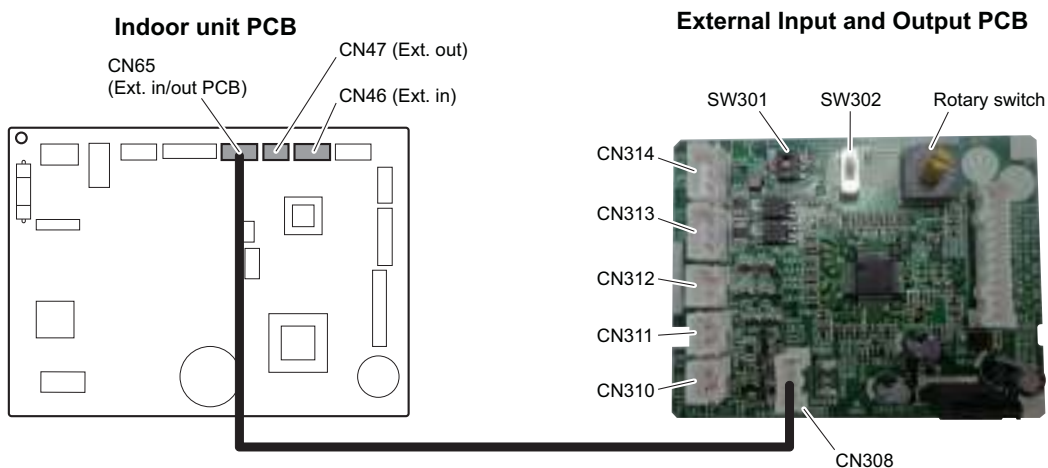

Connecting point		Input/Output	Function	Input select	Input signal
Indoor unit	CN46	Input	Operation/Stop Forced stop	Dry contact	Edge
	CN47	Output	Operation/Stop Error status Indoor unit fan operation status	—	—
External Input and Output PCB (UTY-XCSXZ2)	CN313 CN314	Input	Operation/Stop Forced stop	Dry contact/Apply voltage	Edge/Pulse
	CN313		Forced thermostat off		Edge
	CN310 CN311 CN312	Output	Operation/Stop Error status Indoor unit fan operation status	—	—

NOTE: For details of the switching function, refer to "[Setting of external input and output](#)" on page 05-14.

FIELD WORKING

FIELD WORKING

2-1. External input

With using external input function, some functions on this product can be controlled from an external device.

- “Operation/Stop” mode or “Forced stop” mode can be selected with function setting of indoor unit.
- A twisted pair cable should be used. Maximum length of cable is 150 m.
- Use an external input and output cable with appropriate external dimension, depending on the number of cables to be installed.
- The wire connection should be separate from the power cable line.

■ Indoor unit

Indoor unit functions such as Operation/Stop can be done by using indoor unit connectors.

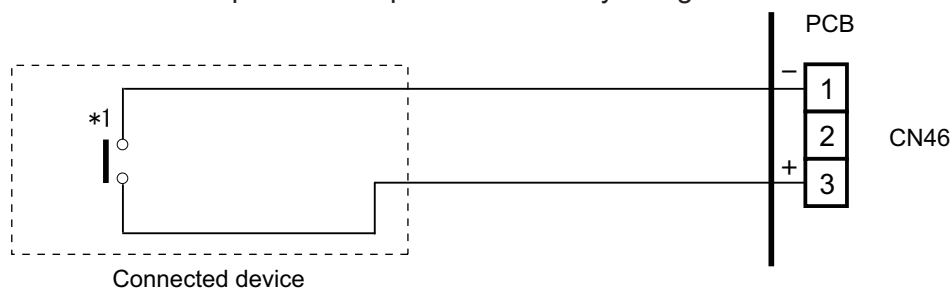

*1: The switch can be used on the following condition: DC 12 V to 24 V, 1 mA to 15 mA.

External Input and Output PCB

The indoor unit Operation/Stop can be set by using the input connector on the PCB.

• Input select

Use either one of these types of connectors according to the application. (Both types of connectors cannot be used simultaneously.)

– Dry contact

In case of internal power supply, set the slide switch of SW301 to "NON VOL" side.

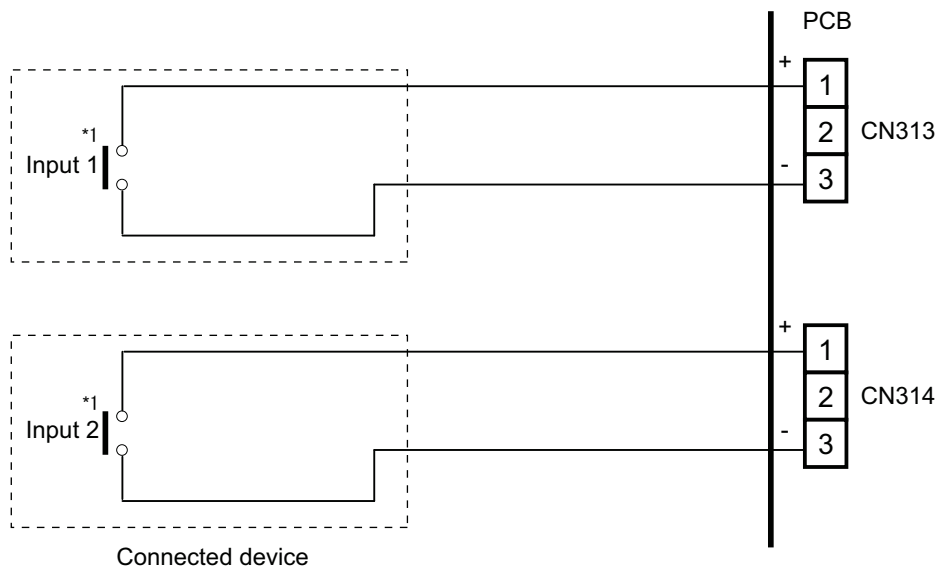

*1: The switches can be used on the following condition: DC 12 V to 24 V, 1 mA to 15 mA.

– Apply voltage

In case of external power supply, set the slide switch of SW301 to "VOL" side.

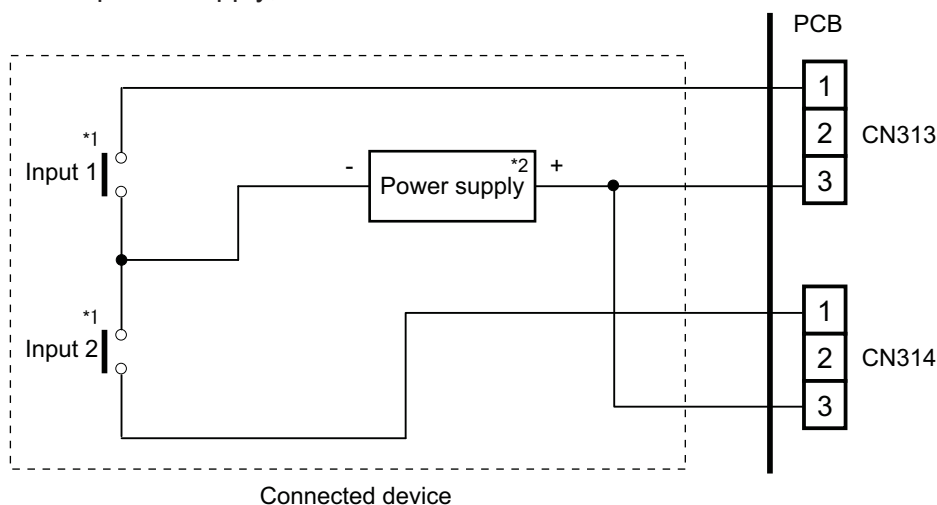

*1: The switches can be used on the following condition: DC 12 V to 24 V, 1 mA to 15 mA.

*2: Make the power supply DC 12 V to 24 V, 10 mA or more.

■ Input signal type

- **Indoor unit**

Input signal type is only "Edge".

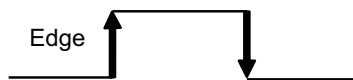

- **External Input and Output PCB**

The input signal type can be selected.

Signal type (edge or pulse) can be switched by the DIP switch 2 (SW302) on the External Input and Output PCB.

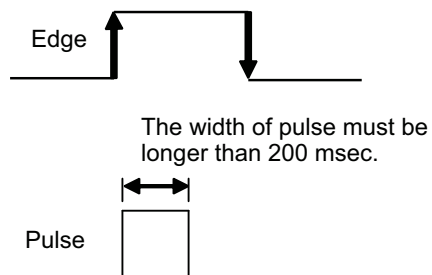

NOTE: The input signal supports the following switch type:

- Edge: Alternate type switch
- Pulse: Momentary type switch

2-2. External output

Use an external output cable with appropriate external dimension, depending on the number of cables to be installed.

Indoor unit

- A twisted pair cable should be used. Maximum length of cable is 25 m.
- Output voltage: High DC 12 V \pm 2 V, Low 0 V.
- Permissible current: 50 mA
- For details, refer to "[Setting of external input and output](#)" on page 05-14.

When indicator, etc. are connected directly

Example: Function setting number 60 is set to "00"

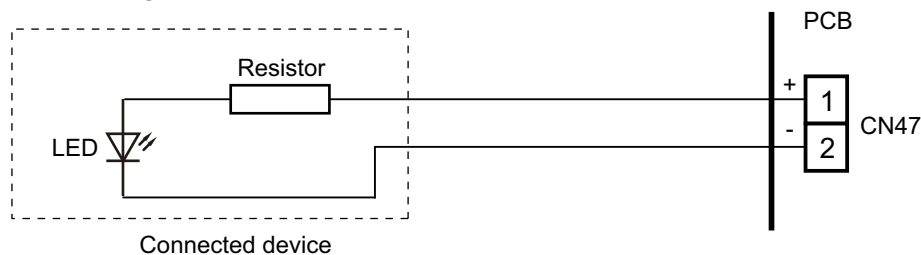

When connecting with a device equipped with a power supply

Example: Function setting number 60 is set to "00"

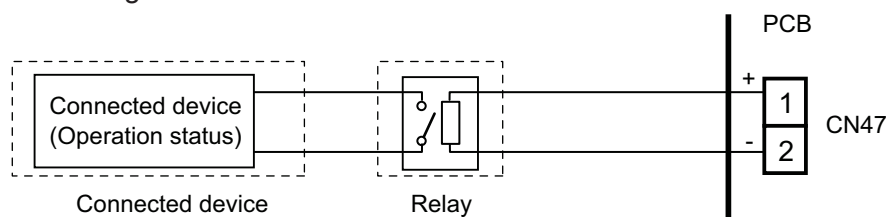

External Input and Output PCB

- A twisted pair cable should be used. Maximum length of cable is 25 m.
- Output voltage: High DC 12 V \pm 2 V, Low 0 V.
- Permissible current: 50 mA
- For details, refer to "[Setting of external input and output](#)" on page 05-14.
- **When indicator or other components are connected directly:**
Example: Rotary SW on External Input and Output PCB is set to "1".

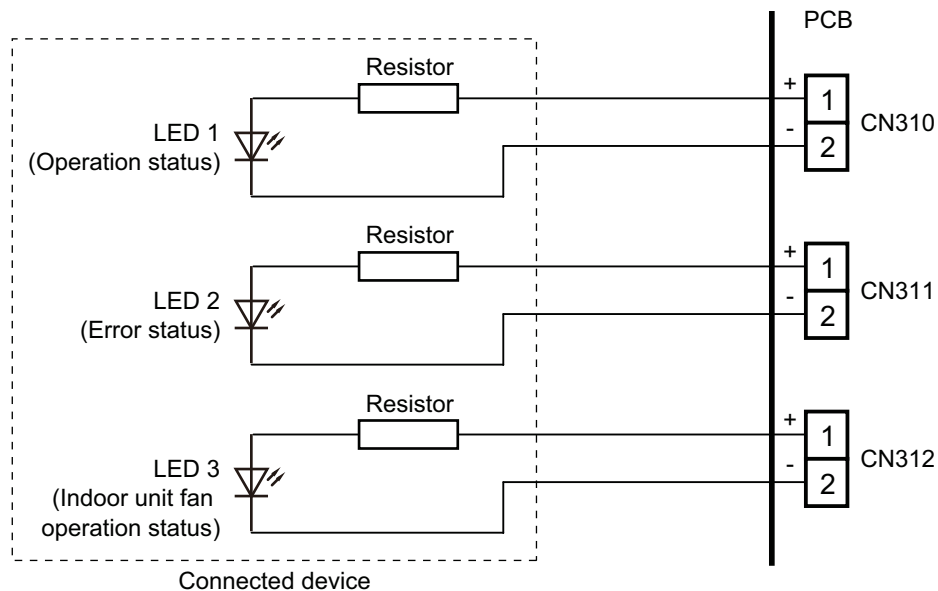

- **When connecting with a device equipped with a power supply:**
Example: Rotary SW on External Input and Output PCB is set to "1".

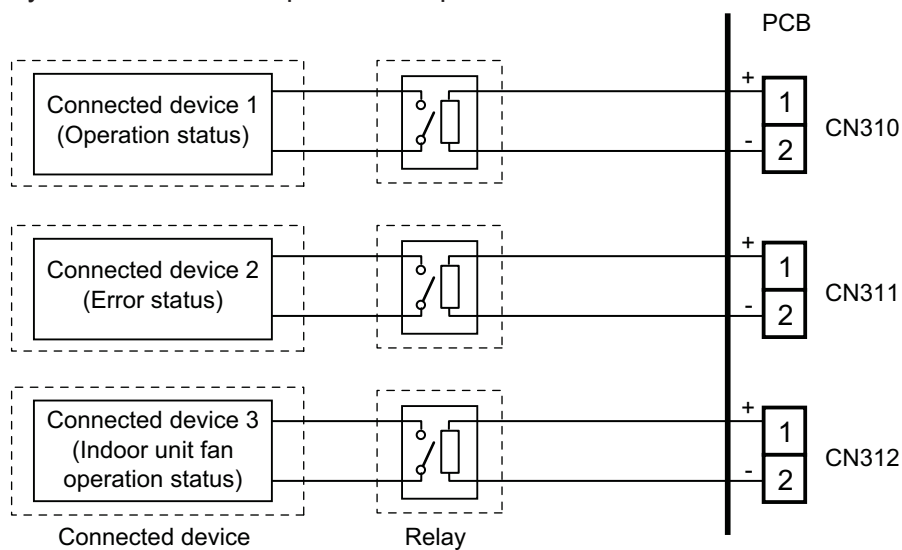

2-3. Setting of external input and output

- Indoor unit

Input		
Connection point	Function setting number 46	Function
CN46	00	Operation/Stop mode 1 (R.C. enabled)
	01	(Setting prohibited)
	02	Forced stop mode
	03	Operation/Stop mode 2 (R.C. disabled)

Output		
Connection point	Function setting number 60	Function
CN47	00	Operation/Stop
	01 to 08	(Setting prohibited)
	09	Error status
	10	Indoor unit fan operation status
	11	(Setting prohibited)

- External Input and Output PCB

Switch setting		Input		Output		
Rotary switch	SW302	CN313	CN314	CN310	CN311	CN312
1	Edge	Operation/Stop	Not available	Operation/Stop	Error status	Indoor unit fan operation status
	Pulse	Operation	Stop			
2	Edge*	Forced thermostat off	Not available	Error status	Indoor unit fan operation status	Not available
3 to 9, A		(Setting prohibited)				
B		Forced thermostat off	Not available	Operation/Stop	Indoor unit fan operation status	Not available
C		Forced thermostat off	Not available	Operation/Stop	Error status	Not available
D		Forced thermostat off	Not available	Operation/Stop	Indoor unit fan operation status	Error status

NOTES:

- When the rotary switch is selected to "1", the operation of the connector input of the indoor unit and the External Input and Output PCB input are the same. The operation content depends on the setting of function setting number 46.
- *: The external input other than "Operation/Stop" is available only when the SW302 is set to "Edge".

2-4. Details of control input function

■ Operation/Stop mode 1

- In the case of "Edge" input

Function setting	External Input and Output PCB		External input	Input signal	Command	
	Rotary switch	SW302				
46-00	—		Input of indoor unit	CN46	Off → On	Operation
	—		Input of indoor unit	CN46	On → Off	Stop
	1	Edge	External Input and Output PCB	CN313	Off → On	Operation
					On → Off	Stop

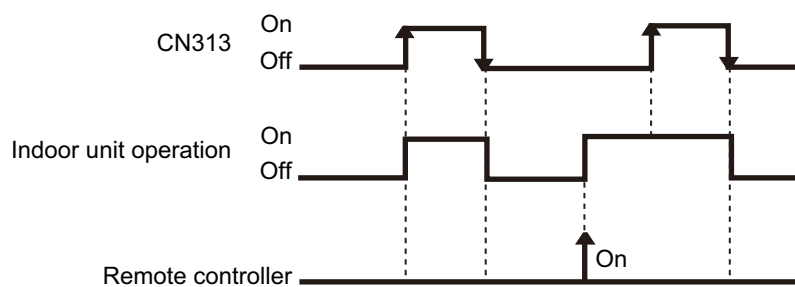

- In the case of "Pulse" input

Function setting	External Input and Output PCB		External input	Input signal	Command
	Rotary switch	SW302			
46-00	1	Pulse	External Input and Output PCB	CN313	Operation
			External Input and Output PCB	CN314	Stop

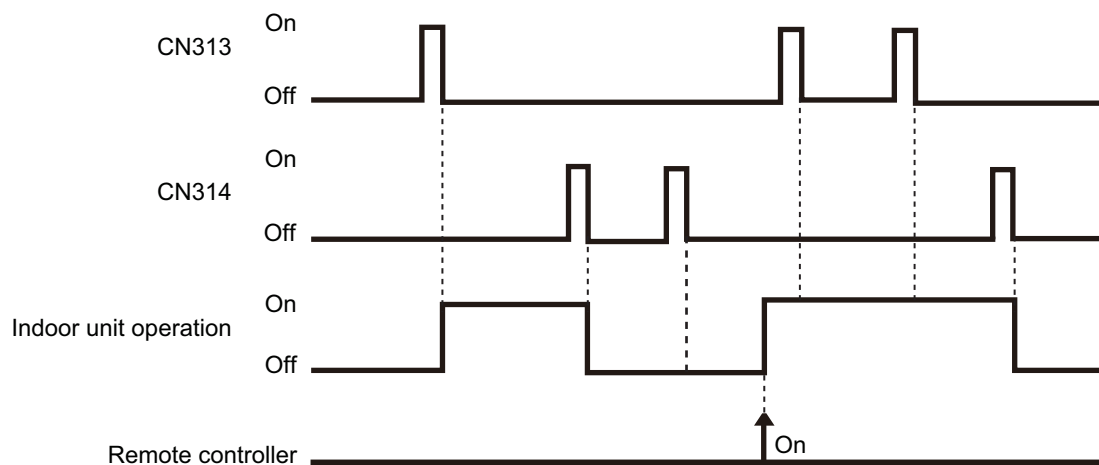

NOTES:

- The last command has priority.
- The indoor units within the same remote controller group operates in the same mode.

■ Forced stop

- In the case of "Edge" input

Function setting	External Input and Output PCB		External input		Input signal	Command
	Rotary switch	SW302				
46-02	—		Input of indoor unit	CN46	Off → On	Forced stop (R.C. disabled)
					On → Off	Normal (R.C. enabled)
	1	Edge	External Input and Output PCB	CN313	Off → On	Forced stop (R.C. disabled)
					On → Off	Normal (R.C. enabled)

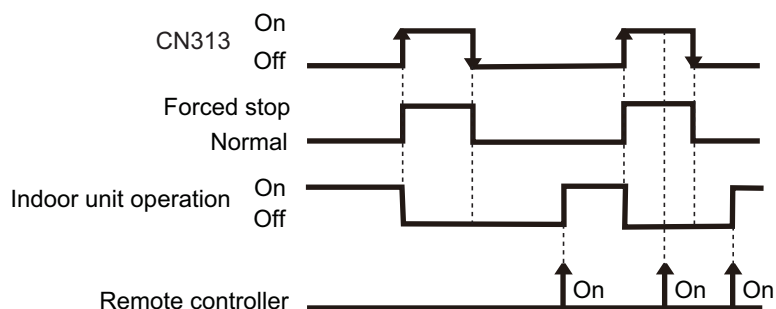

- In the case of "Pulse" input

Function setting	External Input and Output PCB		External input		Input signal	Command
	Rotary switch	SW302				
46-02	1	Pulse	External Input and Output PCB	CN313	Pulse	Forced stop (R.C. disabled)
				CN314		Normal (R.C. enabled)

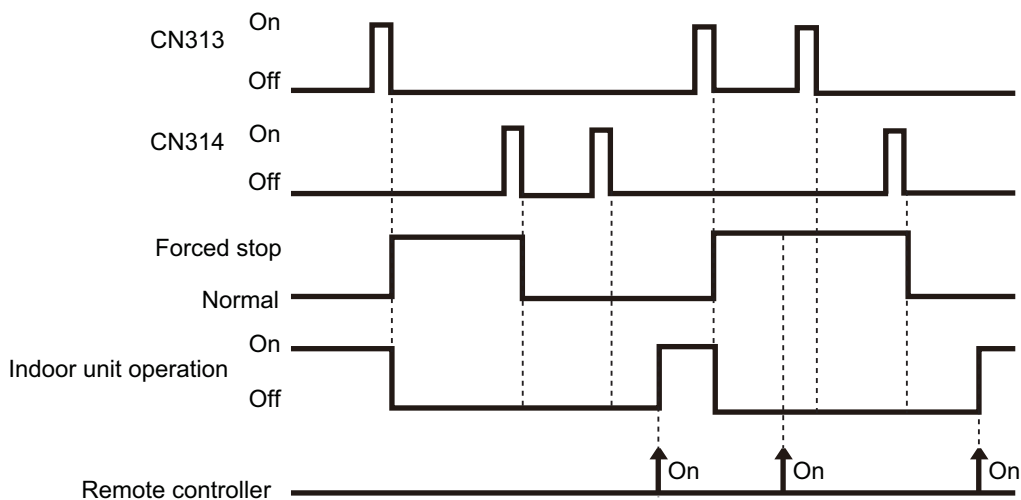

NOTES:

- When the forced stop is triggered, indoor unit stops and Operation/Stop operation by the remote controller is restricted.
- When forced stop function is used with forming a remote controller group, connect the same equipment to each indoor unit within the group.

■ Operation/Stop mode 2

- In the case of “Edge” input

Function setting	External Input and Output PCB		External input	Input signal	Command	
	Rotary switch	SW302				
46-03	—		Input of indoor unit	CN46	Off → On	Operation (R.C. enabled)
	—				On → Off	Stop (R.C. disabled)
	1	Edge	External Input and Output PCB	CN313	Off → On	Operation (R.C. enabled)
					On → Off	Stop (R.C. disabled)

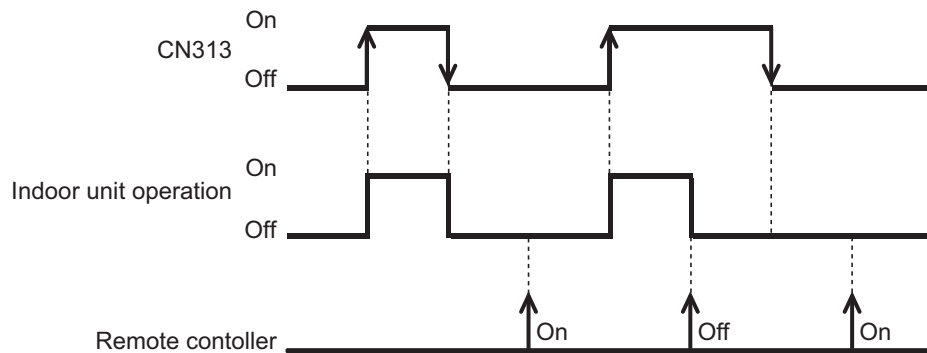

- In the case of “Pulse” input

Function setting	External Input and Output PCB		External input	Input signal	Command
	Rotary switch	SW302			
46-03	1	Pulse	External Input and Output PCB	CN313	Operation (R.C. enabled)
				CN314	Stop (R.C. disabled)

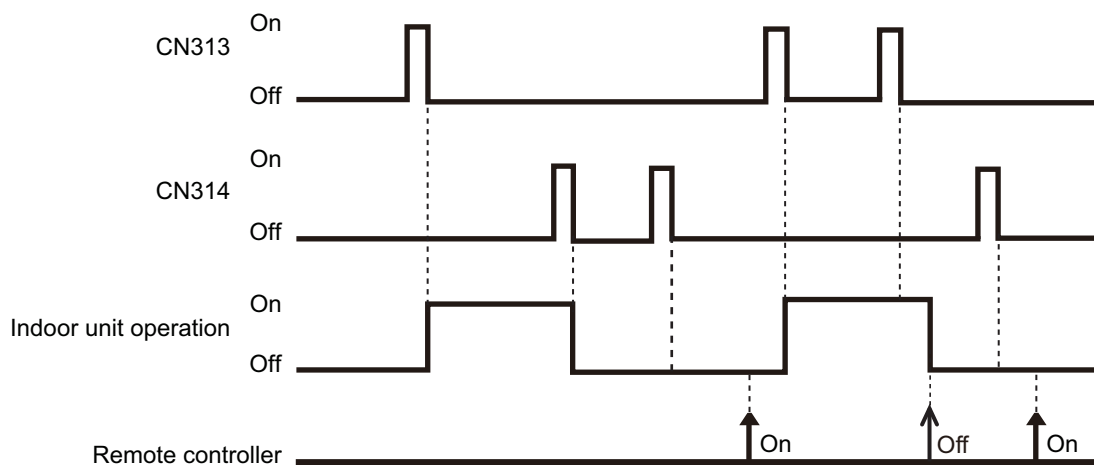

NOTE: When “Operation/Stop” mode 2 function is used with forming a remote controller group, connect the same equipment to each indoor unit within the group.

FIELD WORKING

FIELD WORKING

■ Forced thermostat off

External Input and Output PCB	External input		Input signal	Command
Rotary switch				
2, B, C, D	External Input and Output PCB	CN313	Off → On	Thermostat off
			On → Off	Normal operation

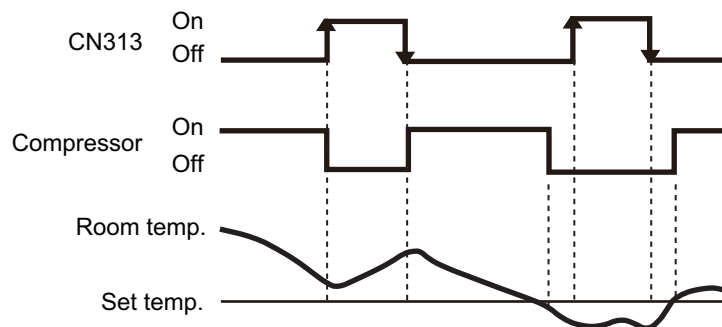

2-5. Details of control output function

■ Operation status

Function setting	External Input and Output PCB	External output		Output signal	Status
	Rotary switch				
60-00	1, 2	Output of indoor unit	CN47	Off → On	Operation
				On → Off	Stop
—	1, B, C, D	External Input and Output PCB	CN310	Off → On	Operation
				On → Off	Stop

The output is low when the unit is stopped.

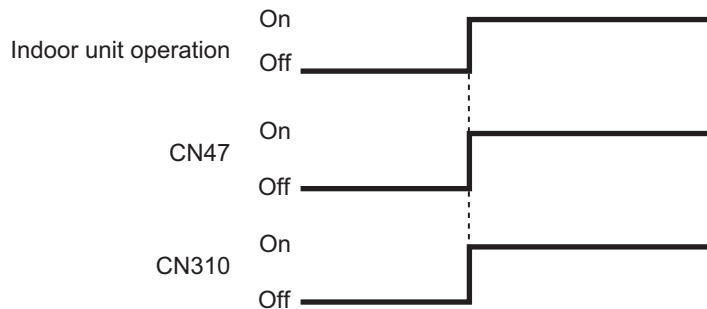

■ Error status

Function setting	External Input and Output PCB	External output		Output signal	Status
	Rotary switch				
60-09	—	Output of indoor unit	CN47	Off → On	Error
				On → Off	Normal
—	2	External Input and Output PCB	CN310	Off → On	Error
				On → Off	Normal
—	1, C	External Input and Output PCB	CN311	Off → On	Error
				On → Off	Normal
—	D	External Input and Output PCB	CN312	Off → On	Error
				On → Off	Normal

The output is on when an error is generated for the indoor unit.

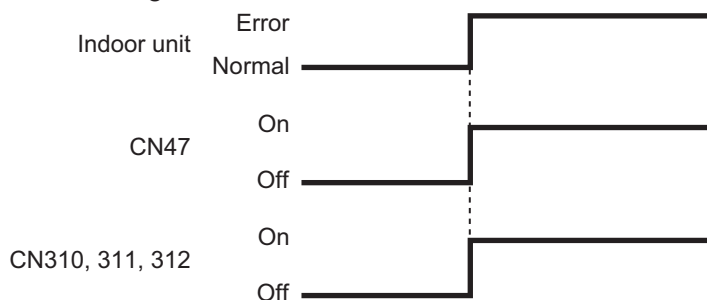

■ Indoor unit fan operation status

Function setting	External Input and Output PCB	External output		Output signal	Status
	Rotary switch				
60-10	C	Output of indoor unit	CN47	Off → On	Fan run
				On → Off	Fan stop
—	2, B, D	External Input and Output PCB	CN311	Off → On	Fan run
				On → Off	Fan stop
—	1	External Input and Output PCB	CN312	Off → On	Fan run
				On → Off	Fan stop

Output signal	Condition
On	The indoor unit fan is operating.
Off	The fan is stopped or during cold air prevention. During thermostat off when in dry mode operation.

