

# AIRSTAGE

AIR TO WATER

High Power series

# FUJITSU

REFRIGERANT **R32**  
INVERTER

## DESIGN & TECHNICAL MANUAL

*Split type*

OUTDOOR UNIT



WOYG100MQL  
WOYG121MQL  
WOYG140MQL

WOYK121MQL  
WOYK140MQL

HYDRAULIC UNIT



WGEK140MQ6-19

WGEK140MQ9-19

**GENERAL Inc.**

**Notices:**

- Product specifications and design are subject to change without notice for future improvement.
- For further details, please check with our authorized dealer.

**Trademarks**

Wi-Fi® is a trademark or registered trademark of Wi-Fi Alliance.

# CONTENTS

**1. OUTDOOR UNIT**

**2. HYDRAULIC UNIT**

**3. CONTROL SYSTEM**



## 1. OUTDOOR UNIT

# CONTENTS

## 1. OUTDOOR UNIT

<b>1. Specifications</b>	<b>01-1</b>
1-1. Nominal capacity and nominal input	01-1
1-2. Technical specifications	01-2
1-3. Electrical specifications	01-2
1-4. Product information	01-3
<b>2. Dimensions</b>	<b>01-6</b>
2-1. Models: WOYG100MQL, WOYG121MQL, WOYG140MQL, WOYK121MQL, and WOYK140MQL	01-6
<b>3. Installation space</b>	<b>01-7</b>
3-1. Space requirement	01-7
<b>4. Piping diagrams</b>	<b>01-10</b>
4-1. Models: WOYG100MQL, WOYG121MQL, WOYG140MQL, WOYK121MQL, and WOYK140MQL	01-10
<b>5. Wiring diagrams</b>	<b>01-11</b>
5-1. Models: WOYG100MQL, WOYG121MQL, and WOYG140MQL	01-11
5-2. Models: WOYK121MQL and WOYK140MQL	01-12
<b>6. External input and output</b>	<b>01-13</b>
6-1. External input	01-13
6-2. External output	01-15
<b>7. Function settings</b>	<b>01-17</b>
7-1. Control PCB and switch buttons location	01-17
7-2. Local setting procedure	01-19
<b>8. Error codes</b>	<b>01-21</b>
<b>9. Heating capacity table</b>	<b>01-22</b>
9-1. Model: WOYG100MQL	01-22
9-2. Models: WOYG121MQL and WOYK121MQL	01-22
9-3. Models: WOYG140MQL and WOYK140MQL	01-22
<b>10. Operation noise (sound pressure)</b>	<b>01-23</b>
10-1. Noise level curve	01-23
10-2. Sound level check point	01-25
<b>11. Operation range</b>	<b>01-26</b>
11-1. Models: WOYG100MQL, WOYG121MQL, WOYG140MQL, WOYK121MQL, and WOYK140MQL	01-26
<b>12. Safety devices</b>	<b>01-27</b>
<b>13. Accessories</b>	<b>01-28</b>
13-1. Models: WOYG100MQL, WOYG121MQL, WOYG140MQL, WOYK121MQL, and WOYK140MQL	01-28

# 1. Specifications

## 1-1. Nominal capacity and nominal input

Model name				WOYG100MQL	WOYG121MQL	WOYG140MQL	
Power supply				1 Ø 230 V ~ 50 Hz			
Heating	Air: +7°C Water: +35°C	Capacity	Minimum	kW	—	—	
			Nominal		10.08	12.55	14.47
			Maximum		15.30	16.19	17.82
		Input power	Nominal	kW	2.18	2.69	3.36
			COP	Nominal	4.62	4.67	4.31
				Nominal	8.24	9.16	10.09
	Air: +7°C Water: +55°C	Capacity	Nominal	kW	2.79	3.06	3.36
		Input power	Nominal	kW	2.95	2.99	3.00
		COP	Nominal	7.70	9.20	10.70	
	Air: -7°C Water: +35°C	Capacity	Nominal	kW	2.37	2.91	3.39
		Input power	Nominal	kW	2.37	2.91	3.39
		COP	Nominal	3.25	3.16	3.16	
	Air: -7°C Water: +55°C	Capacity	Nominal	kW	7.10	8.63	10.28
		Input power	Nominal	kW	3.30	4.03	4.74
		COP	Nominal	2.15	2.14	2.17	

**NOTE:** Test conditions are complied with EN14511:2022

Model name				WOYK121MQL	WOYK140MQL	
Power supply				3 Ø 400 V ~ 50 Hz		
Heating	Air: +7°C Water: +35°C	Capacity	Minimum	kW	—	
			Nominal		12.55	14.47
			Maximum		16.19	17.82
		Input power	Nominal	kW	2.69	3.36
			COP	Nominal	4.67	4.31
				Nominal	9.16	10.09
	Air: +7°C Water: +55°C	Capacity	Nominal	kW	3.06	3.36
		Input power	Nominal	kW	2.99	3.00
		COP	Nominal	9.20	10.70	
	Air: -7°C Water: +35°C	Capacity	Nominal	kW	2.91	3.39
		Input power	Nominal	kW	2.91	3.39
		COP	Nominal	3.16	3.16	
	Air: -7°C Water: +55°C	Capacity	Nominal	kW	8.63	10.28
		Input power	Nominal	kW	4.03	4.74
		COP	Nominal	2.14	2.17	

**NOTE:** Test conditions are complied with EN14511:2022

# 1-2. Technical specifications

Model name				WOYG100MQL	WOYG121MQL WOYK121MQL	WOYG140MQL WOYK140MQL
Enclosure	Material			Steel sheet		
	Color			Dark gray Approximate color of Munsell N 3.30/0.0 Stone gray Approximate color of Munsell 6.0Y 6.10/0.5		
Dimensions (H × W × D)	Net			1,008 × 1,080 × 480		
	Gross	mm		1,196 × 1,174 × 600		
Weight	Net			96	102	
	Gross	kg		113		120
Heat exchanger	Dimensions (H × W × D)		mm	966 × 1,193 × 36.38		966 × 1,185 × 54.57
	Fin pitch			1.45		
	Rows × Stages			2 × 46		3 × 46
	Pipe type			Copper tube		
	Fin type		Type (Material)	Corrugate (Aluminum)		
		Surface treatment	Corrosion resistance (Blue fin)			
Fan	Airflow rate	Heating	m <sup>3</sup> /h	3,590	4,510	5,100
	Type × Qty			Propeller fan × 1		
	Discharge direction		Horizontal			
	Motor quantity		1			
	Motor output		W	111		
Compressor	Type		DC twin rotary			
	Motor output		W	2,550		
Operation range	Ambient temperature	Heating	Minimum	-25		
			Maximum	35		
	Water temperature	Heating	Minimum	17		
			Maximum	60		
Refrigerant	Type (Global Warming Potential)			R32 (675)		
	Charge		g	1,400	1,630	
	Control			Expansion valve (electric type)		
	Number of circuits			1		
Refrigerant oil	Type			RmM68AF		
	Charged volume		l	0.8		
Defrost method			Reverse cycle			
Defrost control			Heat pump side exchanger temperature sensor			
Capacity control method			Inverter control			

# 1-3. Electrical specifications

Model name				WOYG100MQL	WOYG121MQL WOYK121MQL	WOYG140MQL WOYK140MQL
Available voltage range				198—264 V		
Power supply	Voltage		V	1 Ø 230		
	Frequency		Hz	50		
Maximum operating current	Heating		A	14.6	19.1	20.6
	Main fuse (circuit breaker) current			32		
Wiring specifications*1	Power cable		mm <sup>2</sup>	4.0 or more		
	Transmission cable			1.5 or more		
Wiring connection quantity*2	For power supply		N°	2.0 to 3.0		
	For connection with indoor			1.2 to 1.8		
<b>NOTES:</b>						
<ul style="list-style-type: none"> <li>*1: Wiring specification is selected based on Japan Electrotechnical Standard and Codes Committee E0005.</li> <li>*2: Earth wiring is included.</li> </ul>						

Model name				WOYK121MQL	WOYK140MQL
Available voltage range				342—456 V	
Power supply	Voltage		V	3 Ø 400	
	Frequency		Hz	50	
Maximum operating current	Heating		A	20.6	
	Main fuse (circuit breaker) current			16	
Wiring specifications*1	Power cable		mm <sup>2</sup>	2.5 or more	
	Transmission cable			1.5 or more	
Wiring connection quantity*2	For power supply		N°	2.0 to 3.0	
	For connection with indoor			1.2 to 1.8	
<b>NOTES:</b>					
<ul style="list-style-type: none"> <li>*1: Wiring specification is selected based on Japan Electrotechnical Standard and Codes Committee E0005.</li> <li>*2: Earth wiring is included.</li> </ul>					

## 1-4. Product information

Model name			WOYG100MQL		WOYG121MQL WOYK121MQL		WOYG140MQL WOYK140MQL		
Air-to-water heat pump			Yes						
Water-to-water heat pump			No						
Brine-to-water heat pump			No						
Low-temperature heat pump			No						
Equipped with a supplementary heater			Yes						
Heat pump combination heater			Yes*1						
Temperature application		°C	55	35	55	35	55	35	
Rated heat output*2		P <sub>rated</sub>	kW	8	9	10	10	11	12
Seasonal space heating energy efficiency		η <sub>s</sub>	%	131	183	135	183	137	185
Declared capacity for heating for part load at indoor temperature 20 °C and outdoor temperature T <sub>j</sub>									
T <sub>j</sub> = -7°C		P <sub>dh</sub>	kW	7.3	7.5	8.7	8.9	10.1	10.4
T <sub>j</sub> = +2°C		P <sub>dh</sub>	kW	4.4	4.6	5.3	5.4	6.1	6.3
T <sub>j</sub> = +7°C		P <sub>dh</sub>	kW	4.1	4.4	4.1	4.4	4.3	4.5
T <sub>j</sub> = +12°C		P <sub>dh</sub>	kW	4.9	5.0	4.9	5.0	4.9	5.1
T <sub>j</sub> = Bivalent temperature		P <sub>dh</sub>	kW	7.3	7.5	8.7	8.9	10.1	10.4
T <sub>j</sub> = Operation limit temperature		P <sub>dh</sub>	kW	6.7	7.2	8.1	8.5	9.5	10.0
T <sub>j</sub> = -15°C (if TOL < -20°C)		P <sub>dh</sub>	kW	—					
Bivalent temperature		T <sub>biv</sub>	°C	-7					
Cycling interval capacity for heating		P <sub>cych</sub>	kW	Not applicable					
Degradation co-efficient*3		C <sub>dh</sub>		0.90					
Declared coefficient of performance or primary energy ratio for part load at indoor temperature 20 °C and outdoor temperature T <sub>j</sub>									
T <sub>j</sub> = -7°C		COP <sub>d</sub>		2.30	3.18	2.29	3.09	2.32	3.09
T <sub>j</sub> = +2°C		COP <sub>d</sub>		3.26	4.66	3.38	4.62	3.41	4.61
T <sub>j</sub> = +7°C		COP <sub>d</sub>		4.26	5.92	4.37	6.06	4.50	6.24
T <sub>j</sub> = +12°C		COP <sub>d</sub>		5.76	7.52	5.87	7.57	5.97	7.67
T <sub>j</sub> = Bivalent temperature		COP <sub>d</sub>		2.30	3.18	2.29	3.09	2.32	3.09
T <sub>j</sub> = Operation limit temperature		COP <sub>d</sub>		2.01	2.93	2.01	2.86	2.06	2.82
T <sub>j</sub> = -15°C (if TOL < -20°C)		COP <sub>d</sub>		—					
Operation limit temperature		TOL	°C	-10					
Cycling interval efficiency		COP <sub>cyc</sub>		Not applicable					
Heating water operating limit temperature		WTOL	°C	60					
Power consumption in modes other than active mode									
Off mode		P <sub>OFF</sub>	kW	0.014					
Thermostat-off mode		P <sub>TO</sub>	kW	0.018	0.021	0.018	0.021	0.018	0.021
Standby mode		P <sub>SB</sub>	kW	0.014					
Crankcase heater mode		P <sub>CK</sub>	kW	0.000					
Supplementary heater									
Rated heat output*2		P <sub>SUP</sub>	kW	6		6		9	
Type of energy input				Electric					
Other items									
Capacity control				Variable					
Sound power level	Indoor unit	LWA	dB	36	—	36	—	36	—
	Outdoor unit	LWA	dB	56	—	56	—	58	—
Annual energy consumption		Q <sub>HE</sub>	kWh	5,060	3,771	5,879	4,476	6,717	5,132
Emissions of nitrogen oxides		NO <sub>x</sub>	mg/kWh	Not applicable					
Rated airflow rate			m <sup>3</sup> /h	3,590	3,590	3,590	4,510	4,110	5,100
Daily fuel consumption		Q <sub>fuel</sub>	kWh	Not applicable					
Contact details				FUJITSU GENERAL (EURO) GmbH Fritz-Vomfelde-Strasse 26-32 40547 Düsseldorf, Germany					
<b>NOTES:</b>									
<ul style="list-style-type: none"> <li>Product information according to Commission Delegated Regulation (EU) 813/2013</li> <li>Product information is based on the average climate condition.</li> <li>*1: Possible with using an optional component.</li> <li>*2: For heat pump space heaters and heat pump combination heaters, the rated heat output P<sub>rated</sub> is equal to the design load for heating P<sub>design,h</sub>, and the rated heat output of a supplementary heater P<sub>sup</sub> is equal to the supplementary capacity for heating sup (T<sub>j</sub>).</li> <li>*3: If C<sub>dh</sub> is not determined by measurement then the default degradation coefficient is C<sub>dh</sub> = 0.9.</li> </ul>									

# Product fiche

Model name		WGEG140MQ6-19						
		WOYG100MQL		WOYG121MQL		WOYG140MQL		
Temperature application	°C	55	35	55	35	55	35	
Declared load profile		L	L	L	L	L	L	
Seasonal space heating energy efficiency class		A++	A+++	A++	A+++	A++	A+++	
Water heating energy efficiency class		A+	A+	A+	A+	A+	A+	
Rated heat output	kW	8	9	10		11	12	
Supplementary heater	kW	6						
Annual energy consumption	kWh	5,060	3,771	5,879	4,476	6,717	5,132	
Annual electricity consumption	kWh	884						
Annual fuel consumption	GJ	Not applicable						
Seasonal space heating energy efficiency	%	131	183	135	183	137	185	
Water heating energy efficiency	%	116						
Sound power level	Indoor unit	dB						
Work only during off-peak hours		Not applicable						
Specific precautions in assembled, installed, or maintained		Refer to the installation and operating manuals.						
Rated heat output	Colder climate	kW	6	8	6	9	6	11
	Warmer climate	kW	8				9	10
Annual energy consumption	Colder climate	kWh	4,220	4,473	4,220	5,264	4,220	6,303
	Warmer climate	kWh	2,958	2,104	3,025	2,294	3,492	2,842
Annual electricity consumption	Colder climate	kWh	1,265					
	Warmer climate	kWh	771					
Seasonal space heating energy efficiency	Colder climate	%	137	166	137	173	137	169
	Warmer climate	%	141	210	143	211	145	209
Water heating energy efficiency	Colder climate	%	81					
	Warmer climate	%	133					
Sound power level	Outdoor unit	dB	56	—	56	—	58	—

**NOTES:**

- Product fiche according to Commission Delegated Regulation (EU) 811/2013
- Acoustic noise information:
  - The maximum sound power level is less than 70 dB (A) for outdoor unit.
  - According to IEC 704-1 and ISO 3744.
- If the air to water heat pump is operated under higher temperature conditions than those listed, the built-in protection circuit may operate to prevent internal circuit damage. Also, during cooling modes, if the unit is used under conditions of lower temperatures than those listed above, the heat exchanger may freeze, leading to water leakage and other damage.
- Do not use this unit for any purposes other than the Heating and Cooling.

Model name		WGEK140MQ9-19				
		WOYK121MQL		WOYK140MQL		
Temperature application	°C	55	35	55	35	
Declared load profile		L	L	L	L	
Seasonal space heating energy efficiency class		A++	A+++	A++	A+++	
Water heating energy efficiency class		A+	A+	A+	A+	
Rated heat output	kW	10		11	12	
Supplementary heater	kW	9				
Annual energy consumption	kWh	5,879	4,476	6,717	5,132	
Annual electricity consumption	kWh	884				
Annual fuel consumption	GJ	Not applicable				
Seasonal space heating energy efficiency	%	135	183	137	185	
Water heating energy efficiency	%	116				
Sound power level	Indoor unit	dB				
Work only during off-peak hours		Not applicable				
Specific precautions in assembled, installed, or maintained		Refer to the installation and operating manuals.				
Rated heat output	Colder climate	kW	9		11	
	Warmer climate	kW	8	9	10	11
Annual energy consumption	Colder climate	kWh	6,534	5,264	6,499	6,303
	Warmer climate	kWh	3,025	2,294	3,492	2,842
Annual electricity consumption	Colder climate	kWh	1,265			
	Warmer climate	kWh	771			
Seasonal space heating energy efficiency	Colder climate	%	132	173	133	169
	Warmer climate	%	143	211	145	209
Water heating energy efficiency	Colder climate	%	81			
	Warmer climate	%	133			
Sound power level	Outdoor unit	dB	56	—	58	—

**NOTES:**

- Product fiche according to Commission Delegated Regulation (EU) 811/2013
- Acoustic noise information:
  - The maximum sound power level is less than 70 dB (A) for outdoor unit.
  - According to IEC 704-1 and ISO 3744.
- If the air to water heat pump is operated under higher temperature conditions than those listed, the built-in protection circuit may operate to prevent internal circuit damage. Also, during cooling modes, if the unit is used under conditions of lower temperatures than those listed above, the heat exchanger may freeze, leading to water leakage and other damage.
- Do not use this unit for any purposes other than the Heating and Cooling.

## ■ Energy efficiency value

Application: 35°C											
Model name		WOYG100MQL		WOYG121MQL		WOYG140MQL		WOYK121MQL		WOYK140MQL	
Seasonal energy efficiency of heat pump for space heating	%	183		183		183		183		183	
Type of temperature control	-										
Outdoor sensor	-	II	—	II	—	II	—	II	—	II	—
Outdoor sensor + Room thermostat	-	—	VI	—	VI	—	VI	—	VI	—	VI
Bonus	%	2	4	2	4	2	4	2	4	2	4
in average	%	185	187	185	187	187	189	185	187	187	189
in warmer	%	212	214	213	215	211	213	213	215	211	213
in colder	%	168	170	175	177	171	173	175	177	171	173

Application: 55°C											
Model name		WOYG100MQL		WOYG121MQL		WOYG140MQL		WOYK121MQL		WOYK140MQL	
Seasonal energy efficiency of heat pump for space heating	%	131		135		137		135		137	
Type of temperature control	-										
Outdoor sensor	-	II	—	II	—	II	—	II	—	II	—
Outdoor sensor + Room thermostat	-	—	VI	—	VI	—	VI	—	VI	—	VI
Bonus	%	2	4	2	4	2	4	2	4	2	4
in average	%	133	135	137	139	139	141	137	139	139	141
in warmer	%	143	145	145	147	147	149	145	147	147	149
in colder	%	139	141	139	141	139	141	135	137	136	138

## ■ Class of temperature controller

Controller class		II		VI	
Contribution to energy efficiency	%	2		4	

## 2. Dimensions

### 2-1. Models: WOYG100MQL, WOYG121MQL, WOYG140MQL, WOYK121MQL, and WOYK140MQL

Unit: mm

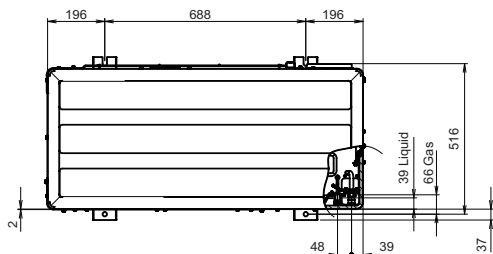

Top view

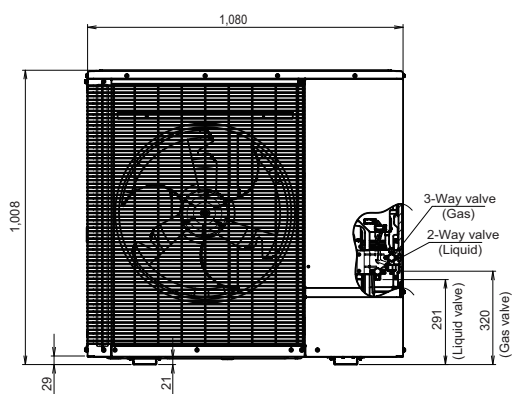

Front view

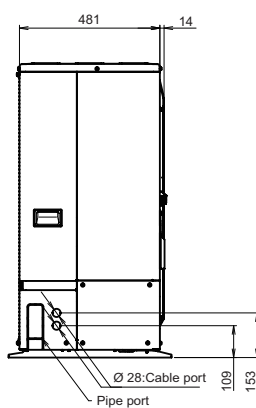

Side view

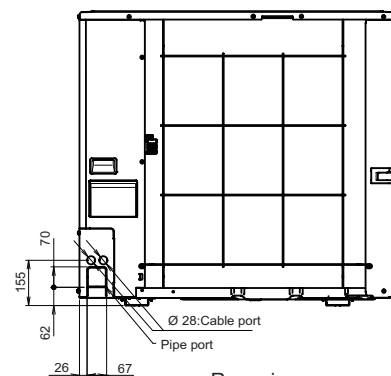

Rear view

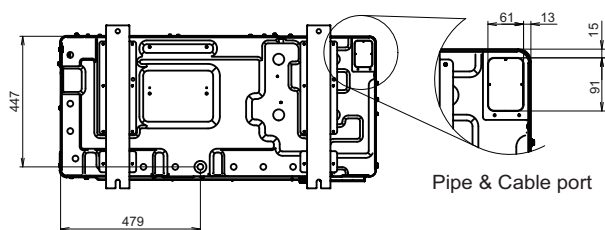
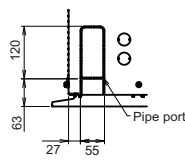

Bottom view

### 3. Installation space

#### 3-1. Space requirement

Provide sufficient installation space for product safety.

**⚠ CAUTION**

Keep the space shown in the installation examples.

If the installation is not performed accordingly, it could cause a short circuit and result in a lack of operating performance.

#### ● Single outdoor unit installation

- When the upper space is open:

Unit: mm

When there are obstacles at the rear only.

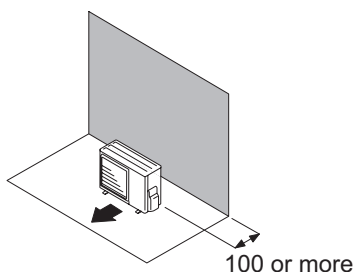

When there are obstacles at the rear and sides.

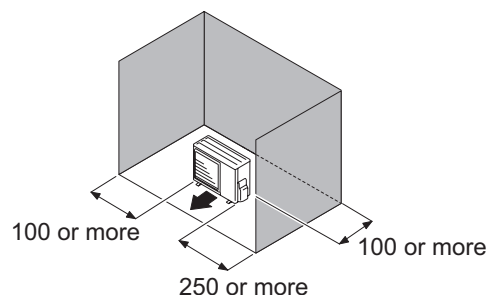

When there are obstacles at the front only.

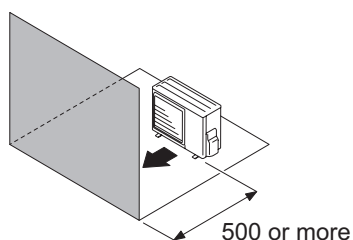

When there are obstacles at the front and rear.

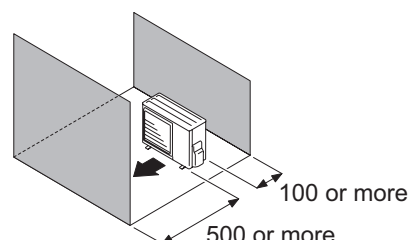

- When an obstruction in the upper space:

Unit: mm

When there are obstacles at the rear and above.

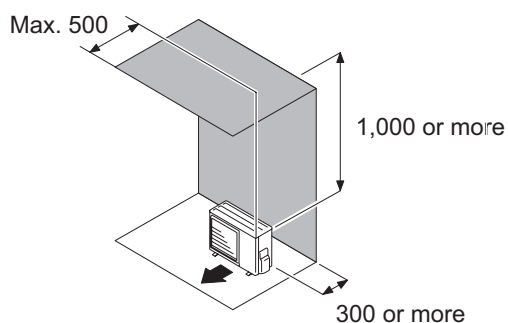

When there are obstacles at the rear, sides, and above.

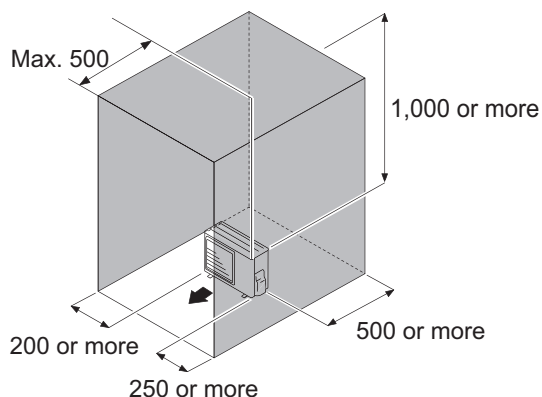

## ● Multiple outdoor unit installation

- Provide at least 250 mm of space between the outdoor units if multiple units are installed.
- When routing the piping from the side of an outdoor unit, provide space for piping.
- No more than 3 units must be installed side by side.  
When 4 units or more are arranged in a line, provide the space as shown in the following example **“When an obstruction in the upper space:”**.

- **When the upper space is open:**

Unit: mm

When there are obstacles at the rear only.

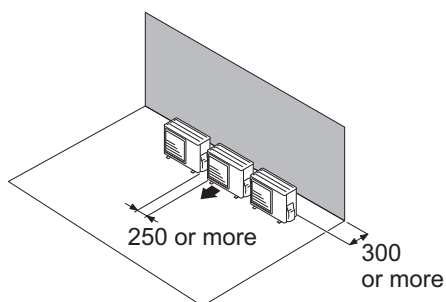

When there are obstacles at the front only.

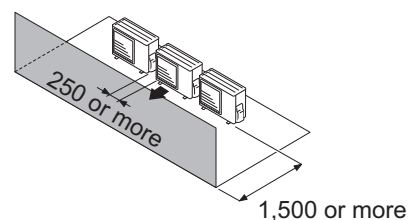

When there are obstacles at the front and rear.

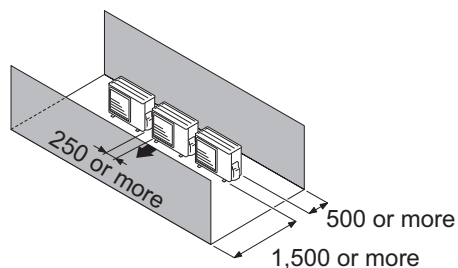

When there are obstacles at the rear and above.

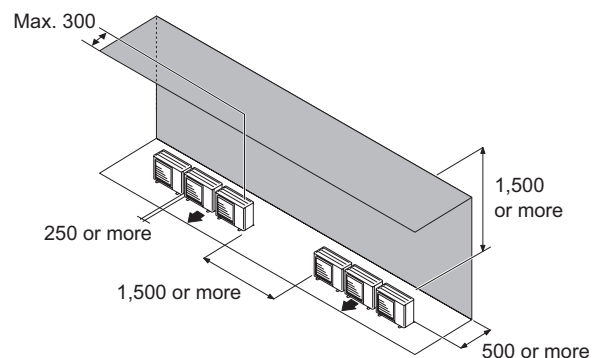

## ● Outdoor unit position

- The outdoor unit must be raised by at least 50 mm from the ground.  
In snowy regions, the height must be increased but must not exceed 1.5 m.
- Fasten the outdoor unit using screws and elastic tightening or toothed lock washers to prevent them from coming loose.

### ⚠ CAUTION

In regions with heavy snowfall, if the outdoor unit's entrance and exit are blocked by snow it may be difficult to heat up and may cause breakdown.

- Build a canopy or position the unit on a high stand (locally purchased).
  - Put the appliance on a solid support to minimize impact and vibration.
  - Do not set the unit directly on the ground as this may generate disruptions.

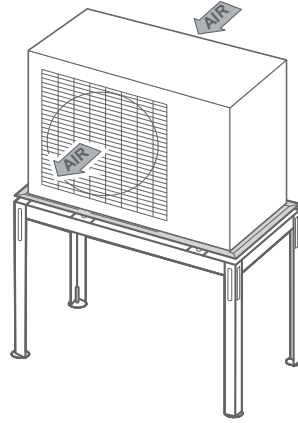

# 4. Piping diagrams

## 4-1. Models: WOYG100MQL, WOYG121MQL, WOYG140MQL, WOYK121MQL, and WOYK140MQL

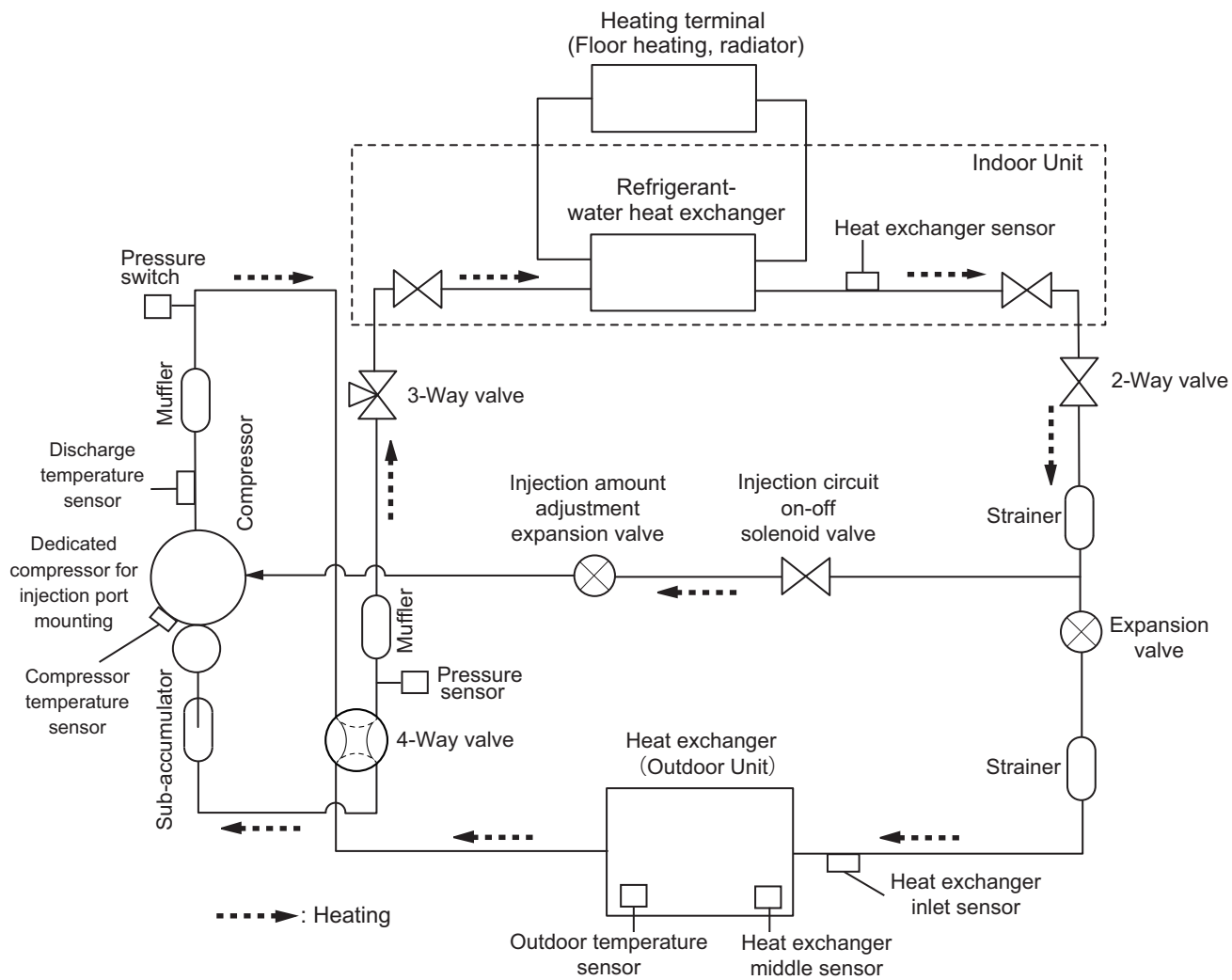

# 5. Wiring diagrams

## 5-1. Models: WOYG100MQL, WOYG121MQL, and WOYG140MQL

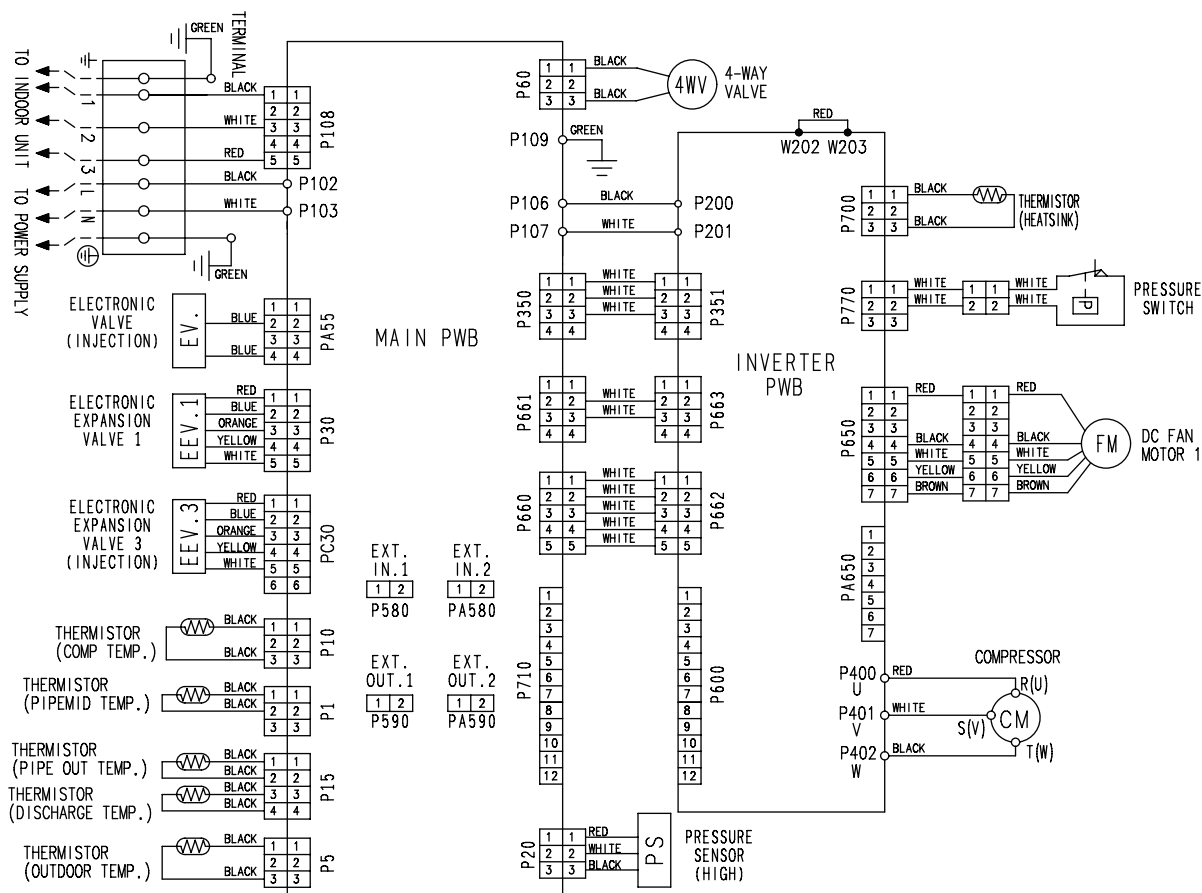

# 5-2. Models: WOYK121MQL and WOYK140MQL

OUTDOOR UNIT

OUTDOOR UNIT

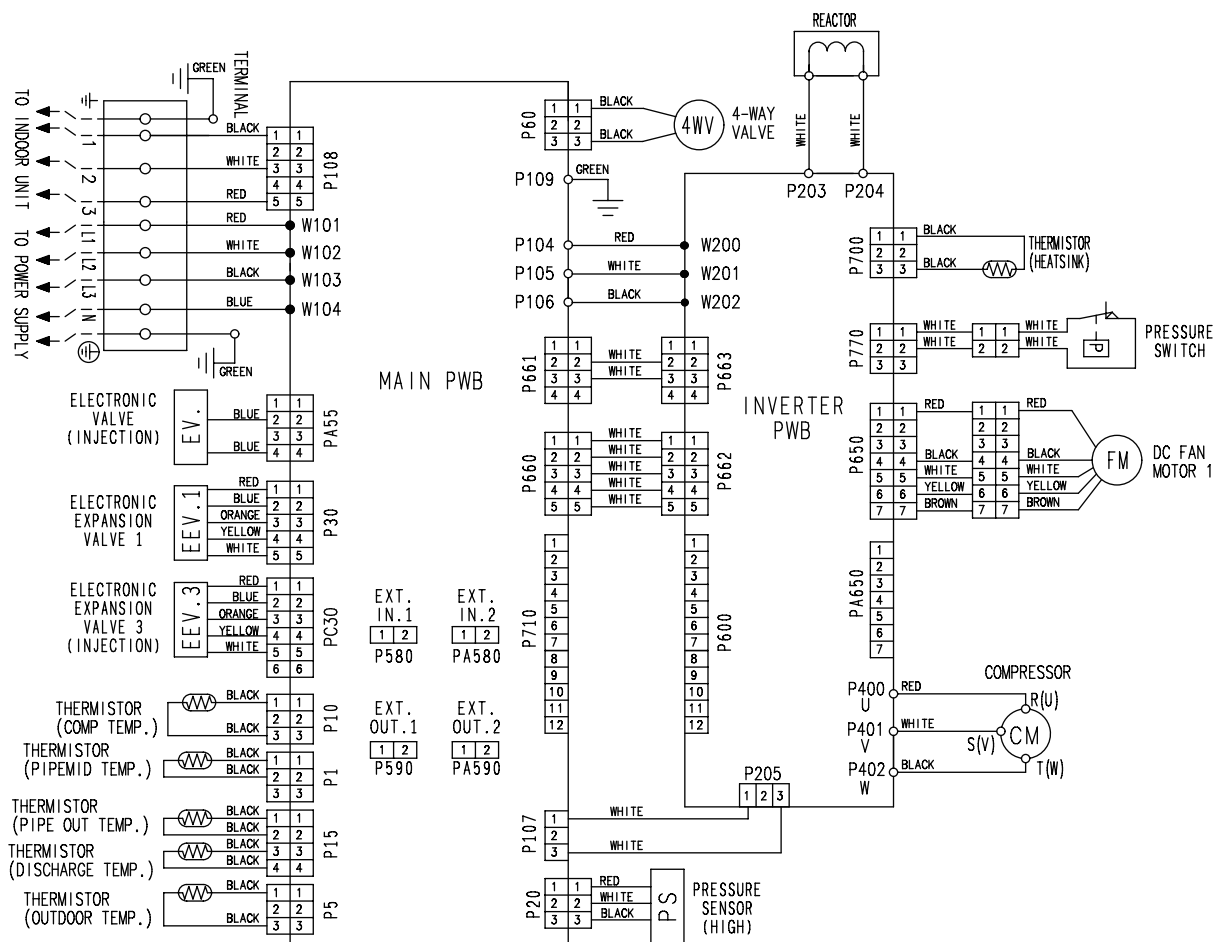

## 6. External input and output

With using external input and output functions, this product can be operated inter-connectedly with an external device.

Function		Connector	Remarks
Input	Low noise mode	P580	See external input/output settings for details.
	Peak cut mode	PA580	
Output	Base heater control	P590	
	Compressor status	PA590	

### 6-1. External input

With using external input function, on/off status of “Low noise mode” and “Peak cut mode” can be specified by the external signal.

#### ■ Low noise mode

In following condition, the operating noise of the outdoor unit reduces comparing from the one in normal operating condition:

The outdoor unit is set to the “Low noise mode” when closing the contact input of a commercial timer or on/off switch to a connector on the control PCB of the outdoor unit.

**NOTE:** Product performance may drop depending on some conditions such as the outdoor temperature.

#### • Circuit diagram example

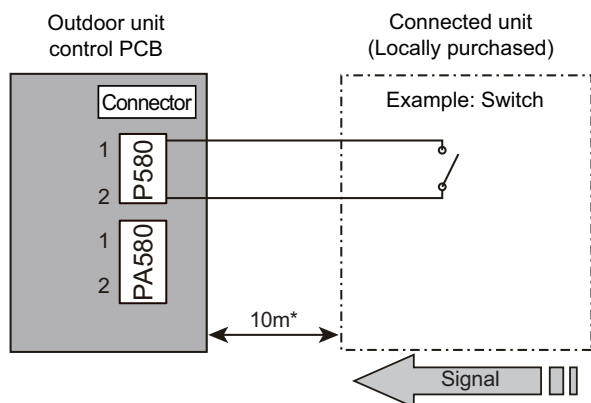

- Contact capacity: DC 24 V or more, 10 mA or more.
- \*: Make the distance from the PCB to the connected unit within 10 m.
- Construct a circuit as shown in this figure with using optional parts mentioned below.
- Input signal: On in “Low noise mode”
- Input signal: Off in normal operation
- To set the level of “Low noise mode,” refer to "Low noise mode" on page 01-19 (under “Local setting procedure”).

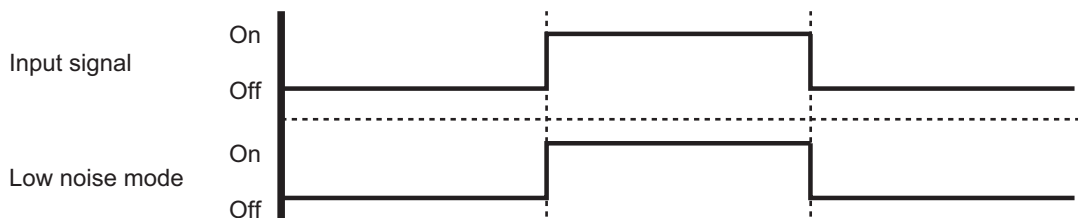

#### • Optional part

Part name	Model name	Exterior
External Connect Kit	UTY-XWZXZ3	External input wire 

## ■ Peak cut mode

By performing following on-site work, operation that suppresses the current value can be enabled: The outdoor unit is set to the “Peak cut mode” when closing the contact input of a commercial timer or on/off switch to a connector on the control PCB of the outdoor unit.

### • Circuit diagram example

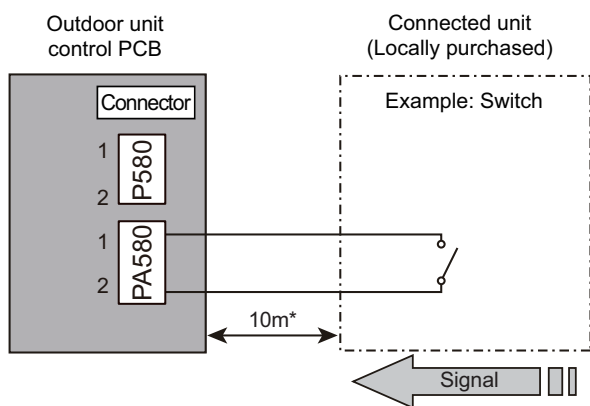

- Contact capacity: DC 24 V or more, 10 mA or more.
- \*: Make the distance from the PCB to the connected unit within 10 m.
- Construct a circuit as shown in this figure with using optional parts mentioned below.
- Input signal: On in “Peak cut mode”
- Input signal: Off in normal operation
- To set the level of “Peak cut mode,” refer to "Peak cut mode" on page 01-20 (under “Local setting procedure”).

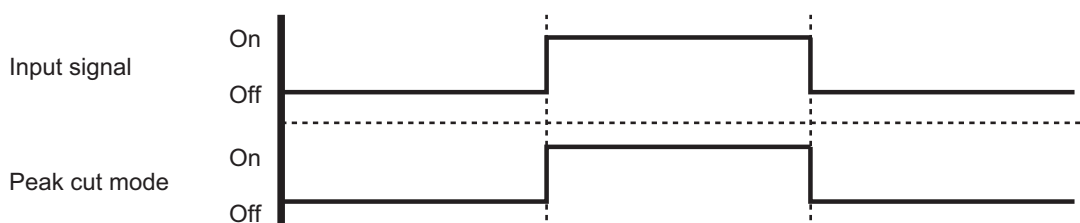

### • Optional part

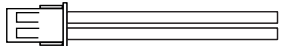
Part name	Model name	Exterior
External Connect Kit	UTY-XWZXZ3	External input wire 

## 6-2. External output

With using external output function, some status signals are transmitted to the control PCB, and the related LED lamp indicates the status of this product.

### ■ Base pan heater control output

Signal on base pan heater operation is generated to run it.

- **Circuit diagram example**

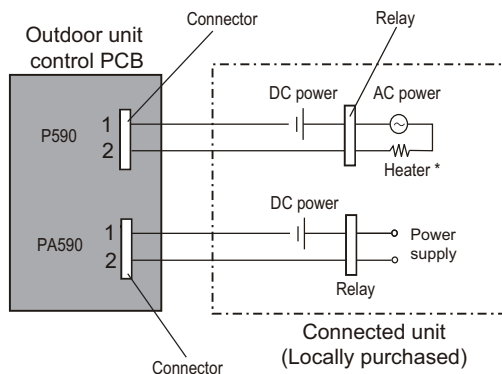

\*: The allowable current is 1A or less

- Input voltage from external power supply: DC 24 V or less and 500 mA or less
- \*1: Make the distance from the PCB to the connected unit within 10 m.
- \*2: The connector depends on the model as follows.
  - 050 model: P800
  - 080-100 model: P590

This is the output signal for the base pan heater. The output signal is on, when the outdoor temperature drops below 2°C, and signal is off when it rises to 5°C.

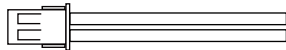

- **Optional part**

Part name	Model name	Exterior
External Connect Kit	UTY-XWZXZ3	External output wire 

## Compressor status output

Signal on compressor operation status is generated when the compressor is running.

### Circuit diagram example

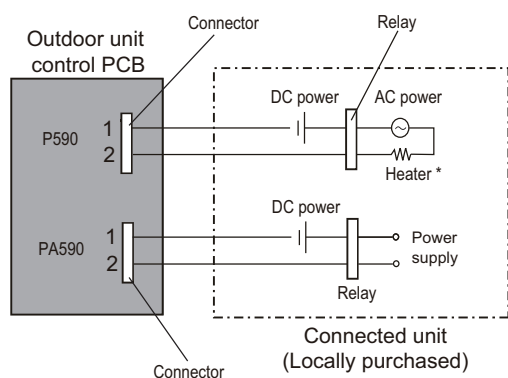

- Input voltage from external power supply: DC 24 V or less and 50 mA or less
- \*: Make the distance from the PCB to the connected unit within 10 m.

\*: The allowable current is 1A or less

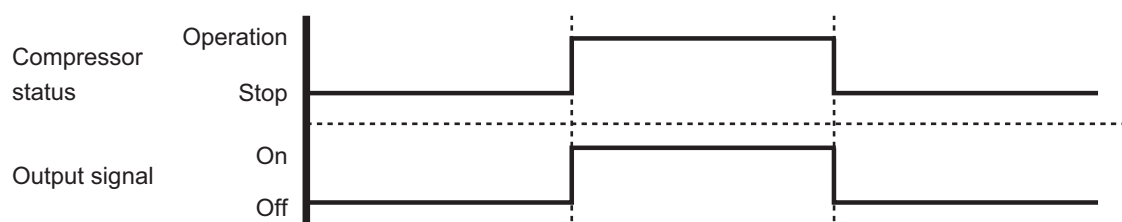

### Optional part

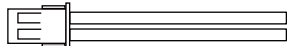
Part name	Model name	Exterior
External Connect Kit	UTY-XWZXZ3	External output wire 

## 7. Function settings

Perform appropriate function setting locally according to the installation environment.

**NOTE:** Incorrect settings can cause a product malfunction.

### ⚠ CAUTION

- Before setting up the switch buttons, discharge the static electricity from your body.
- Never touch the terminals or the patterns on the parts that are mounted on the PCB.

### 7-1. Control PCB and switch buttons location

Control PCB of the outdoor unit is located as shown in the following figure.

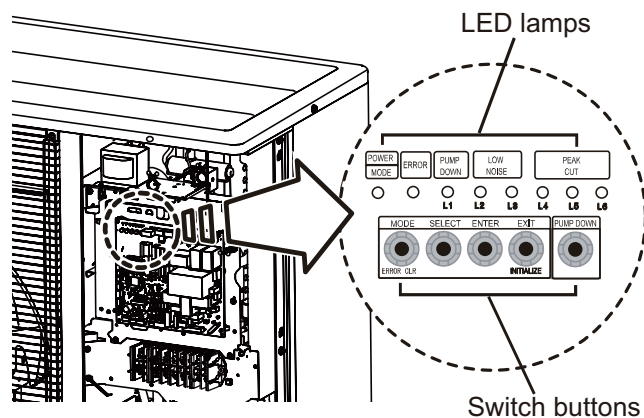

## Switch buttons and the functions

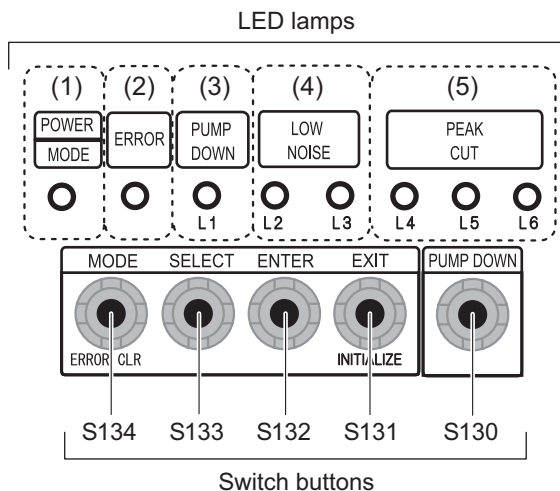

LED lamp			Function or operation method
(1)	POWER/MODE	Green	Lights on while power on. Blinks to show the local setting on the outdoor unit or the error code.
(2)	ERROR	Red	Blinks during error operation.
(3)	PUMP DOWN (L1)	Orange	Lights on during pump down operation.
(4)	LOW NOISE MODE (L2 and L3)	Orange	Lights on during "Low noise mode" when local setting is activated. (Light pattern of L2 and L3 indicates the low noise level.)
(5)	PEAK CUT MODE (L4, L5, and L6)	Orange	Lights on during "Peak cut mode" when local setting is activated. (Light pattern of L4, L5, and L6 indicates the peak cut level.)

Switch button		Function or operation method
S134	MODE	Switches between "Local setting" and "Error code display".
S133	SELECT	Switches between the individual "Local settings" and the "Error code displays".
S132	ENTER	Switches between the individual "Local settings" and the "Error code displays".
S131	EXIT	Returns to "Operation status display".
S130	PUMP DOWN	Starts the pump down operation.

## 7-2. Local setting procedure

**NOTE:** Before performing the function setting, be sure to stop the operation of the heat pump.

### Low noise mode

1. Press the MODE switch button (S134) for 3 seconds or more to switch to "Local setting mode".
2. After confirming the LED lamp of POWER/MODE blinks 9 times, press the ENTER switch button (S132).

POWER MODE	ERROR	PUMP DOWN (L1)	LOW NOISE (L2) (L3)		PEAK CUT (L4) (L5) (L6)		
Blinks (9 times)	○	○	○	○	○	○	○

Sign "○": Lights off

3. Press the SELECT switch button (S133), and adjust the LED lamp as shown below. Then the LED lamp indicates the current setting.

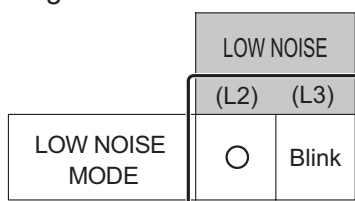

4. Press the ENTER switch button (S132).

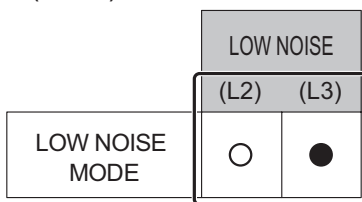

Sign "●": Lights on

5. Press the SELECT switch button (S133), and adjust the LED lamps as shown below.

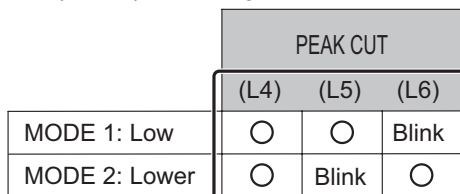

6. Press the ENTER switch button (S132) and fix it.



7. To return to "Operating status display (Normal operation)", press the EXIT switch button (S131).

#### In case of missing how many times you pressed the SELECT and ENTER switch buttons:

1. To return to "Operation status display (Normal operation)", press the EXIT switch button once.
2. Restart from the beginning of setting procedure.

## ■ Peak cut mode

1. Press the MODE switch button (S134) for 3 seconds or more to switch to “Local setting mode”.
2. After confirming the LED lamp of POWER/MODE blinks 9 times, press the ENTER switch button (S132).

POWER MODE	ERROR	PUMP DOWN (L1)	LOW NOISE		PEAK CUT		
			(L2)	(L3)	(L4)	(L5)	(L6)
Blinks (9 times)	○	○	○	○	○	○	○

Sign “○”: Lights off

3. Press the SELECT switch button (S133), and adjust the LED lamp as shown below. Then the LED lamp indicates the current setting.

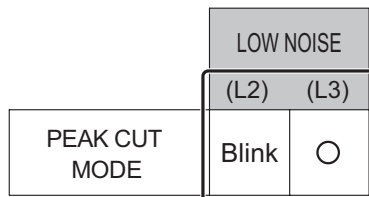

4. Press the ENTER switch button (S132).

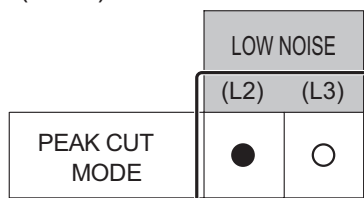

Sign “●”: Lights on

5. Press the SELECT switch button (S133), and adjust the LED lamps as shown below.

	PEAK CUT		
	(L4)	(L5)	(L6)
0 % of rated input ratio	○	○	Blink
50 % of rated input ratio	○	Blink	○
75 % of rated input ratio	○	Blink	Blink
100 % of rated input ratio	Blink	○	○

6. Press the ENTER switch button (S132) and fix it.

	PEAK CUT		
	(L4)	(L5)	(L6)
0 % of rated input ratio	○	○	●
50 % of rated input ratio	○	●	○
75 % of rated input ratio	○	●	●
100 % of rated input ratio	●	○	○

7. To return to “Operating status display (Normal operation)”, press the EXIT switch button (S131).

**NOTE:** When pressed number is lost during setting, you must redo the setting procedure. Return to “Operation status display (Normal operation)” by pressing the EXIT switch button once, and restart from the beginning of the setting procedure.

## 8. Error codes

- Outdoor unit

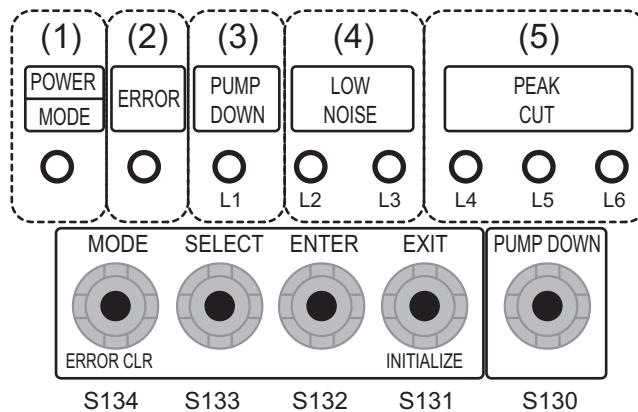

- Check that the LED of ERROR blinks, and then press shortly the switch of ENTER.
- The LED of ERROR will blink several time. For details, refer to the table below. ○: LED off, ●: LED on

Error number	Outdoor unit board						Error contents
	L1	L2	L3	L4	L5	L6	
11	1	1	○	○	●	●	Serial communication error after operation
	1	1	○	●	○	○	Serial communication error during operation
23	2	3	○	○	○	●	Different combinations used by indoor and outdoor units
	2	3	○	○	●	○	Outdoor unit PCB model information error
62	6	2	○	○	○	●	Outdoor unit Main PCB error (model information error)
	6	2	○	○	●	○	Outdoor unit Main PCB error (communication error)
63	6	3	○	○	○	●	Inverter error
65	6	5	○	○	●	●	Outdoor unit IPM error
	6	5	○	○	○	●	IPM board temperature error
71	7	1	○	○	○	●	Discharge thermistor error
72	7	2	○	○	○	●	Compressor thermistor error
73	7	3	○	○	●	○	Heat exchanger thermistor (intermediate) error
	7	3	○	○	●	●	Heat exchanger thermistor (outlet) error
74	7	4	○	○	○	●	Outdoor thermistor error
77	7	7	○	○	○	●	Outdoor unit heat sink temperature thermistor error
78	7	8	○	○	○	●	Expansion valve thermistor error
84	8	4	○	○	○	●	Current sensor error
86	8	6	○	●	○	○	Pressure switch error
	8	6	○	●	●	○	Pressure sensor error
94	9	4	○	○	○	●	Trigger detection
95	9	5	○	○	○	●	Detection of compressor position error
	9	5	○	○	○	●	Compressor start up error
97	9	7	○	○	●	○	Outdoor unit fan1 motor error
A1	10	1	○	○	○	●	Discharge temperature protection
A3	10	3	○	○	○	●	Compressor temperature protection
A5	10	5	○	○	○	●	Low pressure abnormal
AC	10	11	○	○	●	●	Outdoor unit heat sink temperature error

## 9. Heating capacity table

- HC: Heating capacity
- IP: Input power
- COP: Coefficient Of Performance
- Usage environment, such as operation of the heating equipment, room temperature, and control adjustments may cause disparities between practically determined and measured values.
- Values mentioned in the table are calculated based on the maximum capacity without defrost.

### 9-1. Model: WOYG100MQL

Outdoor temperature		Water temperature[ °C]																				
		30			35			40			45			50			55			60		
°CDB	°CWB	HC	IP	COP	HC	IP	COP	HC	IP	COP	HC	IP	COP	HC	IP	COP	HC	IP	COP	HC	IP	COP
		kW			kW			kW			kW			kW			kW			kW		
-25	-26	5.74	2.50	2.30	5.61	2.70	2.08	5.18	2.70	1.92	5.08	2.92	1.74	4.97	3.13	1.59	—	—	—	—	—	—
-20	-21	6.80	2.64	2.58	6.66	2.86	2.33	6.16	2.87	2.15	6.05	3.11	1.95	5.93	3.33	1.78	5.82	3.61	1.62	—	—	—
-15	-16	7.96	2.76	2.88	7.83	3.00	2.61	7.76	3.26	2.38	7.65	3.55	2.16	7.53	3.81	1.98	7.42	4.14	1.79	6.75	4.14	1.63
-10	-11	9.32	2.88	3.23	9.17	3.15	2.91	9.05	3.43	2.64	8.93	3.74	2.39	8.77	4.01	2.19	8.44	4.26	1.98	7.75	4.26	1.82
-7	-8	10.27	2.96	3.47	10.10	3.24	3.12	9.95	3.53	2.82	9.81	3.86	2.54	9.63	4.13	2.33	9.13	4.26	2.14	8.35	4.26	1.96
-5	-7	10.55	2.98	3.54	10.41	3.26	3.19	10.28	3.57	2.88	10.16	3.90	2.60	10.00	4.18	2.39	9.35	4.26	2.19	8.61	4.26	2.02
0	-2	12.35	3.11	3.97	12.14	3.41	3.56	11.90	3.72	3.20	11.88	4.07	2.92	11.23	4.15	2.71	10.24	4.15	2.47	9.27	4.15	2.23
5	3	14.27	3.19	4.47	14.04	3.52	3.99	13.90	3.87	3.59	13.48	4.15	3.25	12.59	4.15	3.04	11.45	4.15	2.76	10.33	4.15	2.49
7	6	15.53	3.19	4.87	15.30	3.54	4.33	15.11	3.91	3.86	14.44	4.15	3.48	13.52	4.15	3.26	12.29	4.15	2.96	11.08	4.15	2.67
10	8	16.41	3.18	5.16	16.18	3.54	4.57	15.96	3.93	4.06	15.14	4.15	3.65	14.20	4.15	3.42	12.89	4.15	3.11	11.58	4.15	2.79
15	10	16.96	3.14	5.40	16.05	3.34	4.80	14.55	3.34	4.35	13.12	3.34	3.92	12.33	3.34	3.69	11.20	3.34	3.35	9.86	3.34	2.95
20	15	17.93	3.10	5.79	17.26	3.34	5.16	15.74	3.34	4.71	14.18	3.34	4.24	13.34	3.34	3.99	12.03	3.34	3.60	10.63	3.34	3.18
25	19	18.93	3.07	6.18	17.96	3.23	5.56	16.41	3.23	5.08	14.82	3.23	4.59	13.92	3.23	4.31	12.40	3.23	3.84	11.10	3.23	3.44
30	22	20.58	3.01	6.83	19.69	3.23	6.10	18.00	3.23	5.57	16.25	3.23	5.03	15.06	3.23	4.66	13.35	3.23	4.14	11.90	3.23	3.69
35	24	21.78	2.98	7.32	20.98	3.23	6.50	19.10	3.23	5.92	17.24	3.23	5.34	15.83	3.23	4.90	14.02	3.23	4.34	12.47	3.23	3.86

### 9-2. Models: WOYG121MQL and WOYK121MQL

Outdoor temperature		Water temperature[ °C]																				
		30			35			40			45			50			55			60		
°CDB	°CWB	HC	IP	COP	HC	IP	COP	HC	IP	COP	HC	IP	COP	HC	IP	COP	HC	IP	COP	HC	IP	COP
		kW			kW			kW			kW			kW			kW			kW		
-25	-26	6.13	2.68	2.28	6.01	2.90	2.07	5.18	2.70	1.92	5.08	2.92	1.74	4.97	3.13	1.59	—	—	—	—	—	—
-20	-21	7.23	2.84	2.55	7.11	3.08	2.31	6.16	2.87	2.15	6.05	3.11	1.95	5.93	3.33	1.78	5.82	3.61	1.62	—	—	—
-15	-16	8.45	2.97	2.85	8.33	3.23	2.58	8.29	3.51	2.36	8.20	3.83	2.14	8.09	4.11	1.97	8.00	4.48	1.79	6.75	4.14	1.63
-10	-11	9.92	3.11	3.19	9.76	3.39	2.88	9.66	3.70	2.61	9.56	4.04	2.37	9.41	4.33	2.17	9.29	4.72	1.97	7.93	4.37	1.82
-7	-8	10.90	3.19	3.42	10.74	3.49	3.08	10.62	3.81	2.78	10.49	4.17	2.52	10.32	4.47	2.31	10.24	4.84	2.12	8.82	4.51	1.96
-5	-7	11.92	3.28	3.63	11.03	3.52	3.14	10.93	3.85	2.84	10.83	4.22	2.57	10.69	4.52	2.37	10.46	4.84	2.16	9.21	4.58	2.01
0	-2	13.08	3.36	3.89	12.89	3.69	3.49	12.68	4.04	3.14	12.67	4.42	2.87	12.48	4.70	2.66	11.52	4.72	2.44	10.50	4.72	2.22
5	3	15.07	3.43	4.39	14.86	3.79	3.92	14.76	4.17	3.54	14.64	4.60	3.18	14.03	4.72	2.97	12.84	4.72	2.72	11.71	4.72	2.48
7	6	16.40	3.43	4.78	16.19	3.80	4.25	16.02	4.21	3.80	15.88	4.66	3.41	15.01	4.72	3.18	13.74	4.72	2.91	12.52	4.72	2.65
10	8	17.32	3.42	5.06	17.05	3.80	4.48	16.91	4.23	4.00	16.77	4.69	3.57	15.74	4.72	3.33	14.39	4.72	3.05	13.07	4.72	2.77
15	10	17.88	3.39	5.27	17.61	3.77	4.67	16.87	4.03	4.18	15.37	4.03	3.81	14.42	4.03	3.57	13.05	4.03	3.24	11.92	4.03	2.95
20	15	18.84	3.36	5.61	18.59	3.75	4.96	17.98	4.03	4.46	16.46	4.03	4.08	15.44	4.03	3.83	14.05	4.03	3.48	12.72	4.03	3.15
25	19	19.50	3.23	6.04	17.96	3.23	5.56	16.41	3.23	5.08	14.82	3.23	4.59	13.92	3.23	4.31	12.40	3.23	3.84	11.10	3.23	3.44
30	22	21.40	3.23	6.63	19.69	3.23	6.10	18.00	3.23	5.57	16.25	3.23	5.03	15.06	3.23	4.66	13.35	3.23	4.14	11.90	3.23	3.69
35	24	22.79	3.23	7.06	20.99	3.23	6.50	19.10	3.23	5.92	17.24	3.23	5.34	15.83	3.23	4.90	14.02	3.23	4.34	12.47	3.23	3.86

### 9-3. Models: WOYG140MQL and WOYK140MQL

Outdoor temperature		Water temperature[ °C]																				
		30			35			40			45			50			55			60		
°CDB	°CWB	HC	IP	COP	HC	IP	COP	HC	IP	COP	HC	IP	COP	HC	IP	COP	HC	IP	COP	HC	IP	COP
		kW			kW			kW			kW			kW			kW			kW		
-25	-26	6.38	2.79	2.28	6.24	3.02	2.07	6.16	3.25	1.89	6.07	3.52	1.73	5.93	3.77	1.58	—	—	—	—	—	—
-20	-21	7.55	2.95	2.56	7.41	3.19	2.32	7.30	3.45	2.12	7.23	3.74	1.93	7.08	4.00	1.77	7.03	4.34	1.62	—	—	—
-15	-16	9.36	3.31	2.83	9.23	3.60	2.56	9.15	3.91	2.34	9.13	4.24	2.15	8.36	4.22	1.98	8.25	4.59	1.80	8.14	4.99	1.63
-10	-11	10.95	3.44	3.18	10.80	3.76	2.87	10.71	4.09	2.62	10.59	4.47	2.37	9.71	4.44	2.19	9.58	4.84	1.98	9.45	5.27	1.79
-7	-8	12.05	3.55	3.39	11.89	3.88	3.07	11.75	4.23	2.78	11.61	4.62	2.52	10.66	4.57	2.33	10.51	4.99	2.11	10.34	5.43	1.90
-5	-7	12.43	3.58	3.47	12.30	3.92	3.14	12.18	4.29	2.84	12.08	4.69	2.57	11.13	4.63	2.40	11.00	5.06	2.17	10.86	5.53	1.97
0	-2	14.40	3.72	3.87	14.22	4.08	3.48	14.03	4.48	3.13	13.89	4.91	2.83	12.72	4.81	2.64	12.56	5.27	2.38	11.73	5.41	2.17
5	3	16.58	3.76	4.41	16.35	4.15	3.94	16.11	4.58	3.52	16.03	5.04	3.18	14.79	4.96	2.98	14.54	5.41	2.69	13.25	5.41	2.45
7	6	18.05	3.75	4.81	17.82	4.16	4.28	17.60	4.60	3.82	17.47	5.10	3.43	16.11	5.06	3.18	15.54	5.41	2.87	14.17	5.41	2.62
10	8	19.10	3.74	5.10	18.86	4.16	4.54	18.62	4.62	4.03	18.45	5.12	3.60	17.03	5.11	3.33	16.29	5.41	3.01	14.85	5.41	2.74
15	10	19.68	3.69	5.33	19.46	4.11	4.74	19.21	4.57	4.20	17.56	4.61	3.81	16.33	4.61	3.54	14.93	4.61	3.24	13.64	4.61	2.96
20	15	20.22	3.66	5.52	19.98	4.09	4.88	19.71	4.55	4.33	18.26	4.61	3.96	17.15	4.61	3.72	15.74	4.61	3.41	14.32	4.61	3.11
25	19	20.46	3.66	5.59	19.14	3.69	5.19	17.60	3.69	4.77	16.12	3.69	4.37	15.14	3.69	4.10	13.75	3.69	3.73	12.42	3.69	3.37
30	22	22.36	3.62	6.18	20.95	3.69	5.68	19.30	3.69	5.23	17.71	3.69	4.80	16.44	3.69	4.46	14.94	3.69	4.05	13.49	3.69	3.66
35	24	23.82	3.59	6.64	22.40	3.69	6.07	20.59	3.69	5.58	18.82	3.69	5.10	17.45	3.69	4.73	15.81	3.69	4.29	14.02	3.69	3.80

# 10. Operation noise (sound pressure)

## 10-1. Noise level curve

■ Model: WOYG100MQL

● Heating

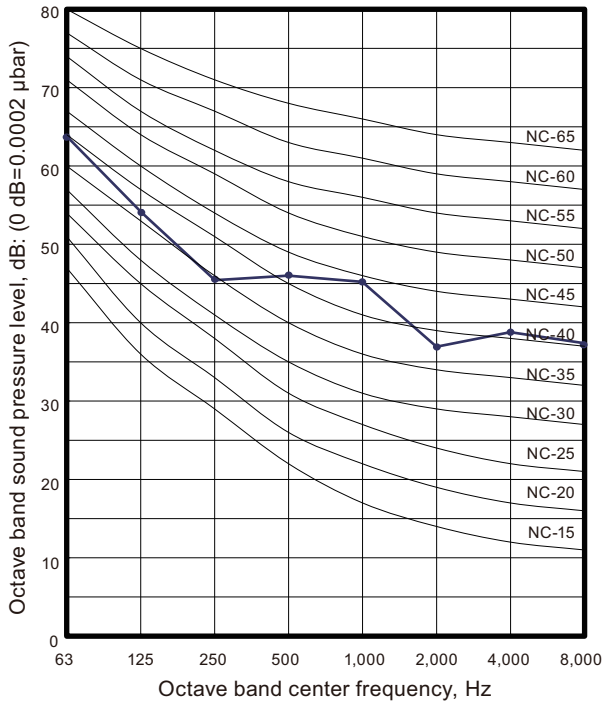

■ Model: WOYG121MQL

● Heating

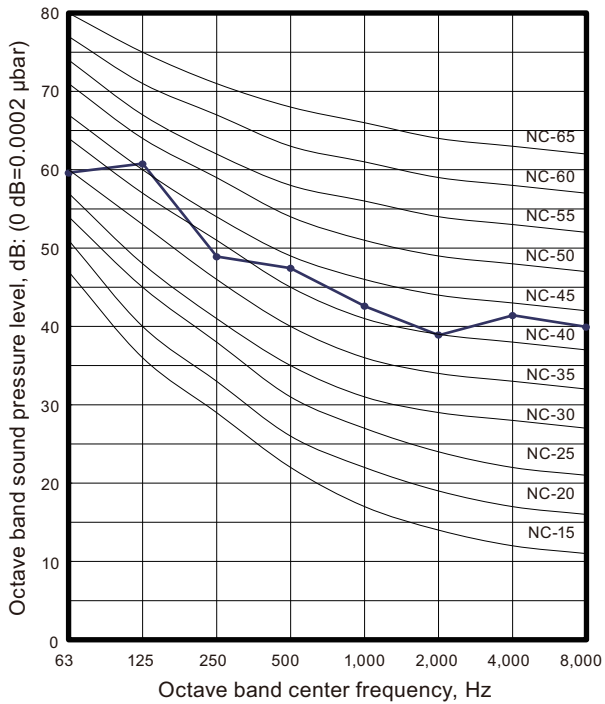

■ Model: WOYG140MQL

● Heating

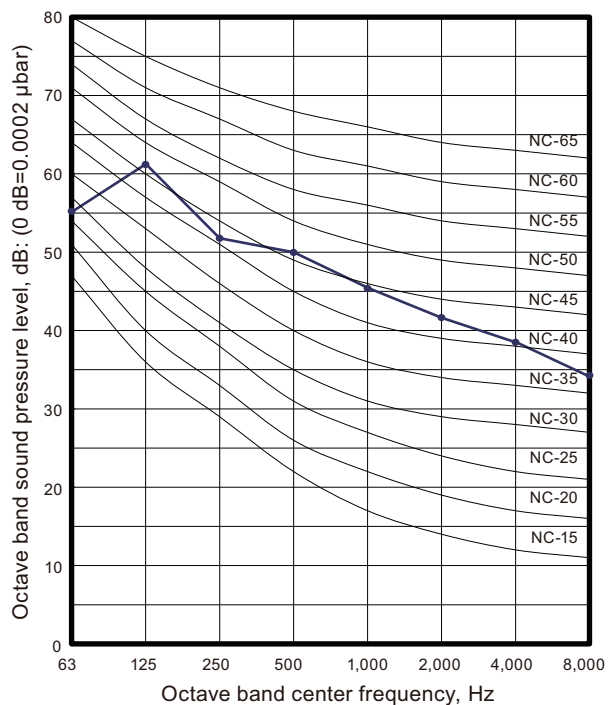

■ Model: WOYK121MQL

● Heating

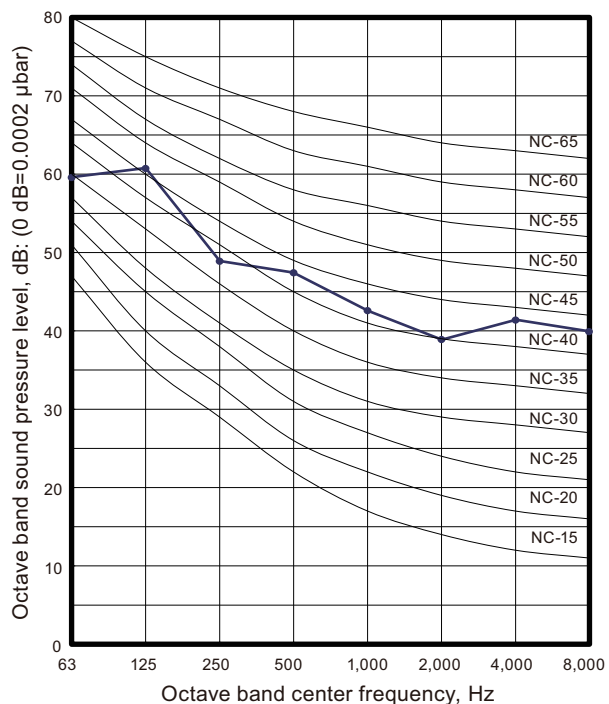

■ Model: WOYK140MQL

● Heating

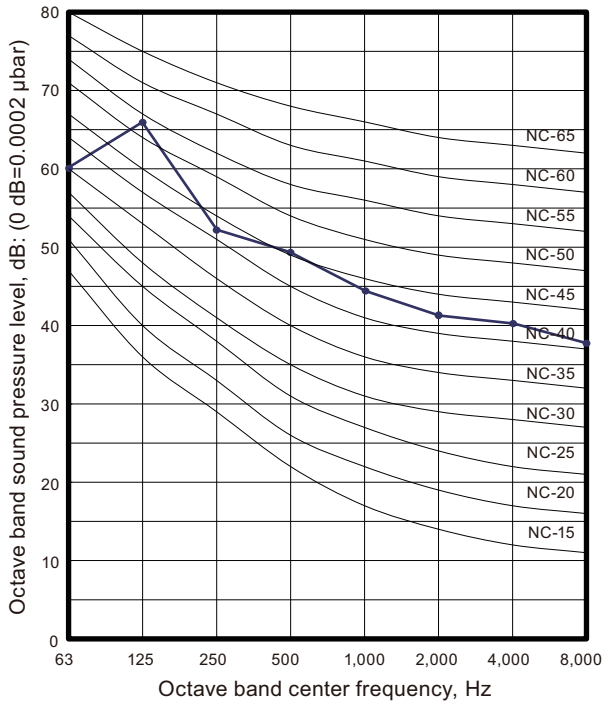

10-2. Sound level check point

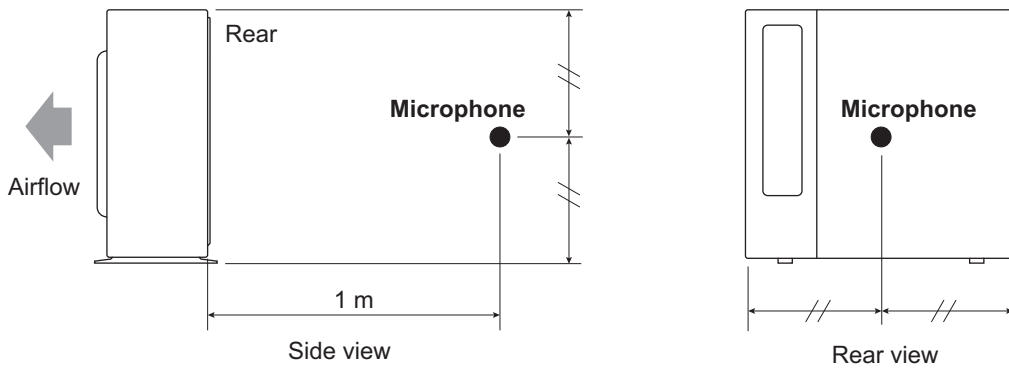

**NOTE:** Detailed shape of the actual outdoor unit might be slightly different from the one illustrated above.

## 11. Operation range

### 11-1. Models: WOYG100MQL, WOYG121MQL, WOYG140MQL, WOYK121MQL, and WOYK140MQL

- Operating mode: Heating, Domestic hot water

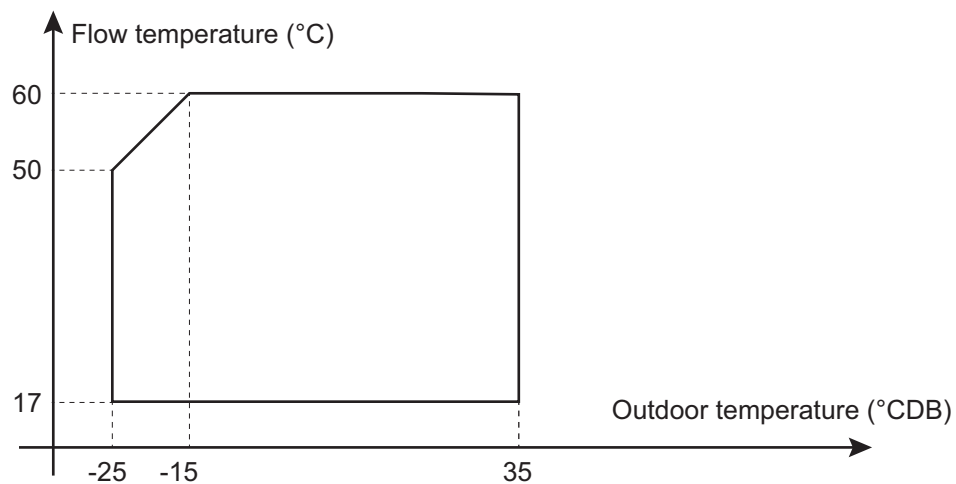





## 12. Safety devices

Type of protection	Protection form		Model	
			WOYG100MQL WOYG121MQL WOYG140MQL	WOYK121MQL WOYK140MQL
Circuit protection	Current fuse (PCB)		AC250 V, 50 A AC250 V, 10 A AC250 V, 3.15 A	AC500 V, 30 A AC250 V, 10 A
Fan motor protection	Thermal protection	Activate	115 ±15°C Fan motor stop	
		Reset	70°C Fan motor restart	
Compressor protector	Thermal protection program (Compressor temp.)	Activate	108°C Compressor stop	
		Reset	After 3 minutes and 80°C or less Compressor restart	
	Thermal protection program (Discharge temp.)	Activate	110°C Compressor stop	
		Reset	After 7 minutes Compressor restart	
High pressure protection	Pressure switch	Activate	4.2 <sup>+0</sup> <sub>-0.15</sub> MPa Compressor stop	
		Reset	After 3 minutes and 3.2 ±0.15 MPa Compressor restart	
	Pressure sensor	Activate	4.2 MPa Compressor stop	
		Reset	After 3 minutes and 3.0 MPa Compressor restart	

## 13. Accessories

### 13-1. Models: WOYG100MQL, WOYG121MQL, WOYG140MQL, WOYK121MQL, and WOYK140MQL

Name and shape	Qty
 Installation manual	1
 Drain pipe	1
 Drain cap	9
 One-touch bush	2

## 2. HYDRAULIC UNIT

# CONTENTS

## 2. HYDRAULIC UNIT

<b>1. Specifications</b> .....	<b>02-1</b>
1-1. Technical specifications .....	02-1
1-2. Electrical specifications .....	02-2
<b>2. Dimensions</b> .....	<b>02-3</b>
2-1. Models: WGEG140MQ6-19 and WGEK140MQ9-19 .....	02-3
<b>3. Installation space</b> .....	<b>02-4</b>
3-1. Models: WGEG140MQ6-19 and WGEK140MQ9-19 .....	02-4
<b>4. Piping diagrams</b> .....	<b>02-5</b>
4-1. Models: WGEG140MQ6-19 and WGEK140MQ9-19 .....	02-5
<b>5. Wiring diagrams</b> .....	<b>02-7</b>
5-1. Model: WGEG140MQ6-19 .....	02-7
5-2. Model: WGEK140MQ9-19 .....	02-8
<b>6. Pipe connections</b> .....	<b>02-9</b>
6-1. Hydraulic connections .....	02-9
6-2. Refrigeration connections .....	02-10
<b>7. Electrical connections</b> .....	<b>02-11</b>
7-1. Overview .....	02-11
7-2. Cable dimensions and protection rating .....	02-12
<b>8. Hydraulic performance</b> .....	<b>02-15</b>
8-1. Models: WGEG140MQ6-19 and WGEK140MQ9-19 .....	02-15
<b>9. Safety devices</b> .....	<b>02-16</b>
<b>10. Accessories</b> .....	<b>02-17</b>

# 1. Specifications

## 1-1. Technical specifications

Model name		Hydraulic unit		WGEG140MQ6-19			WGEK140MQ9-19	
		Outdoor unit		WOYG100MQL	WOYG121MQL	WOYG140MQL	WOYK121MQL	WOYK121MQL
Input power	Heating	Rated	kW	0.16			0.16	
		Maximum*1		6			9	
		DHW*2		1.2			1.2	
Enclosure		Material	Front Panel 8/10 mm DC01 + EZ (5μ)			Front Panel 8/10 mm DC01 + EZ (5μ)		
		Color	White			White		
Dimensions(H × W × D)	Net	mm	1,786 × 598 × 624			1,786 × 598 × 624		
	Gross		1,900 × 750 × 750			1,900 × 750 × 750		
Weight	Net (Empty / Full of water)	kg	135 / 342			135 / 342		
	Gross		147			147		
Water capacity		l	15 / 190			15 / 190		
Main components	Pump	Type	Water cooled			Water cooled		
		Speed setting	Variable speed			Variable speed		
		Input power*3	W	75			75	
		Pump rankW		A			A	
	Expansion vessel	Volume	l	12			12	
		Max. water pressure	bar	8			8	
		Pre-pressure		1			1	
	DHW tank	Type	Enamel coated steel			Enamel coated steel		
		Water volume	l	190			190	
		Max. water pressure	bar	10.0			10.0	
		Anti-corrosion	Titanium anode (ACI)			Titanium anode (ACI)		
	Safety valve	bar	3			3		
	Manometer	Yes			Yes			
	Drain valve/Fill valve	Yes			Yes			
	Distribution valve	Yes			Yes			
Air purge valve	Yes			Yes				
Water circuit	Connection pipe diameter	Flow	mm (in)	Ø19.05 (3/4)			Ø19.05 (3/4)	
		Return	mm (in)	Ø19.05 (3/4)			Ø19.05 (3/4)	
DHW connection	Connection pipe diameter	Flow	mm (in)	Ø19.05 (3/4)			Ø19.05 (3/4)	
		Return	mm (in)	Ø19.05 (3/4)			Ø19.05 (3/4)	
Refrigerant circuit	Connection method	Liquid	Flare			Flare		
		Gas	Flare			Flare		
	Connection pipe diameter	Liquid	mm (in)	Ø9.53 (3/8)			Ø9.53 (3/8)	
		Gas	mm (in)	Ø15.88 (5/8)			Ø15.88 (5/8)	
Operation range	Water side	Heating	°C	17 to 60			17 to 60	
<b>NOTES:</b> <ul style="list-style-type: none"> <li>*1: With electric backup heater</li> <li>*2: With electric DHW heater</li> <li>*3: The value is at full speed and full flow.</li> </ul>								

HYDRAULIC UNIT

HYDRAULIC UNIT

# 1-2. Electrical specifications

Model name		Hydraulic unit		WGEG140MQ6-19			WGEK140MQ9-19		
		Outdoor unit		WOYG100MQL	WOYG121MQL	WOYG140MQL	WOYK121MQL	WOYK121MQL	
Electrical heater (Backup heater)	Type			—			—		
	Input power	Maximum	kW	6			9		
	Power supply	Phase		1			3		
		Frequency		Hz	50			50	
		Voltage		V	230			400	
	Current	Running current		A	26.1			26.1	
Electrical heater (DHW heater)	Type			—			—		
	Power supply	Phase		1			3		
		Frequency		Hz	50			50	
		Voltage		V	230			400	
	Current	Running current		A	5.2			5.2	
Wiring spec.	Backup heater power supply	Main fuse (circuit breaker) current		A	32			20	
		Connection cable		mm <sup>2</sup>	6 × 3			2.5 × 4	
	DHW heater power supply	Main fuse (circuit breaker) current		A	16			16	
		Connection cable		mm <sup>2</sup>	1.5 × 3			1.5 × 3	
	Hydraulic unit to outdoor unit	Connection cable		mm <sup>2</sup>	1.5 × 4			1.5 × 4	
		Limited wiring length		m	Not available			Not available	

HYDRAULIC UNIT

HYDRAULIC UNIT

## 2. Dimensions

### 2-1. Models: WGEK140MQ6-19 and WGEK140MQ9-19

Unit: mm

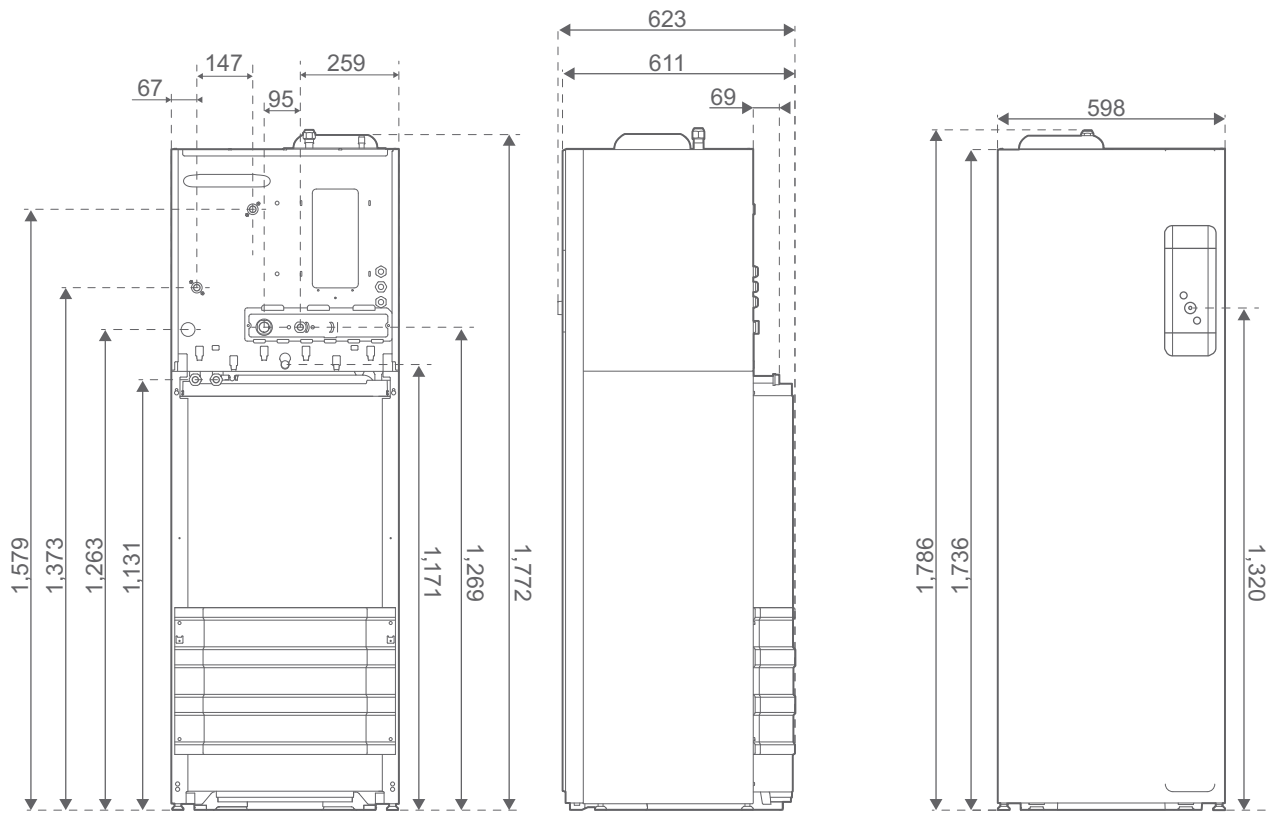

HYDRAULIC  
UNIT

HYDRAULIC  
UNIT

### 3. Installation space

#### 3-1. Models: WGEK140MQ6-19 and WGEK140MQ9-19

Unit: mm

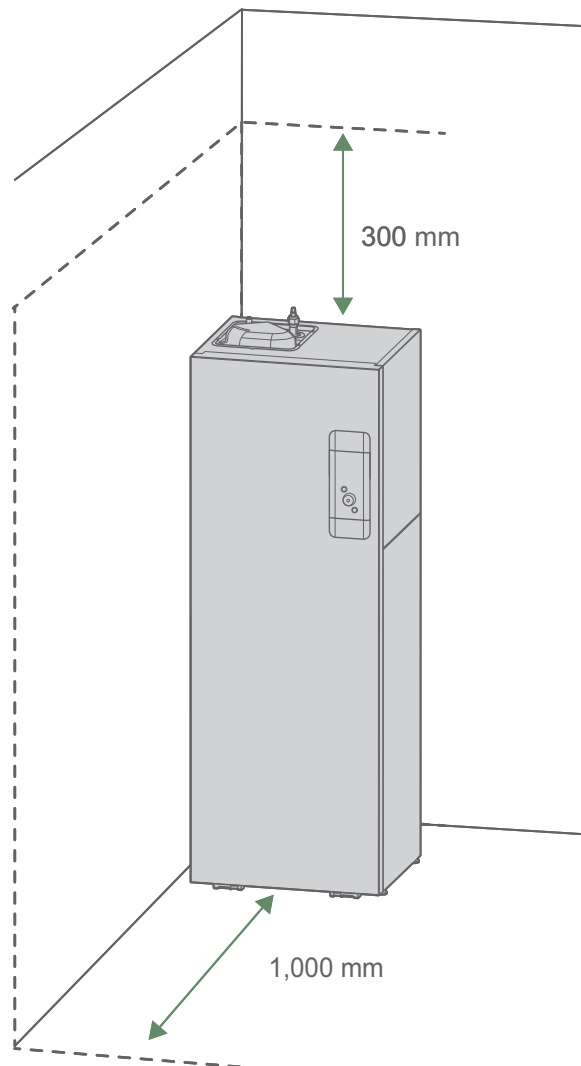

- Choose the location of the appliance after discussion with the client.
- The installation space should comply with the current regulations.
- To facilitate maintenance and allow access to the various parts, we recommend that you provide sufficient space all the way around the hydraulic unit.

# 4. Piping diagrams

## 4-1. Models: WGEK140MQ6-19 and WGEK140MQ9-19

- 1 heating circuit

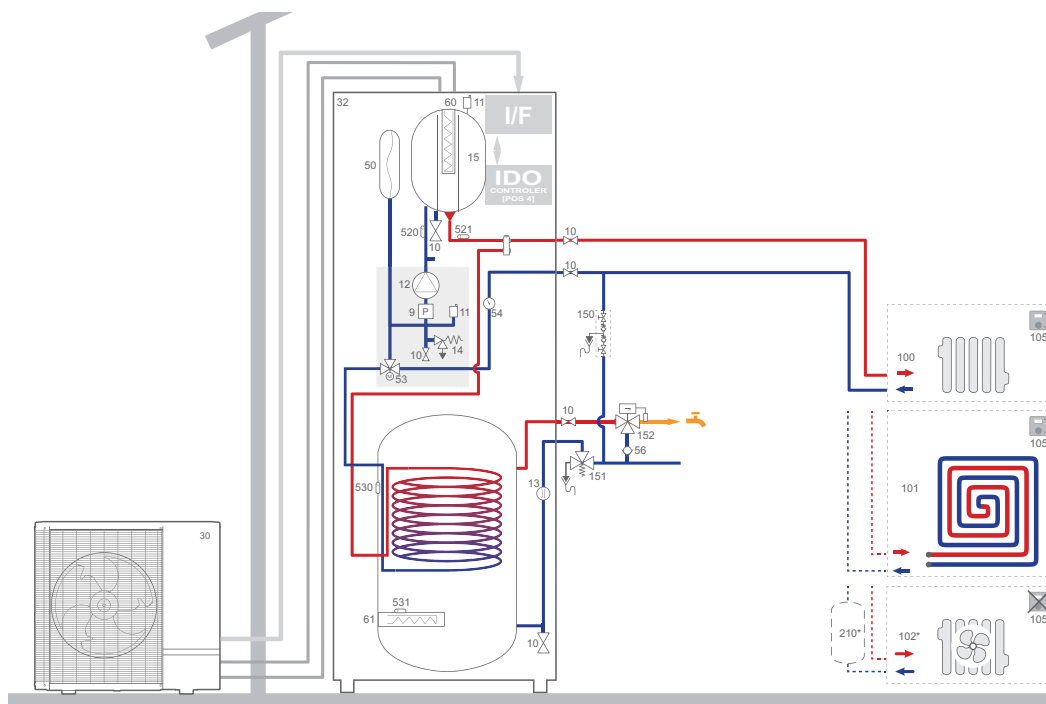

9 - Pressure sensor (Value)	56 - Non-return valve	210 - Buffer tank
10 - Valve	60 - Electrical heating backup	250 - 2-circuit kit
11 - Drain valves	61 - DHW electrical backup	251 - Combination circuit kit
12 - Circulation pump	100 - Radiator	252 - Mixing valve
13 - Flowmeter	101 - Underfloor heating system	520 - Return temperature sensor (heating circuit)
14 - Safety valve	102 - Dynamic radiator (fan convactor)	521 - Flow temperature sensor (heating circuit)
32 - Dual hydraulic unit*	105 - Thermostat or room sensor (zone 1)	530 - DHW temperature sensor
50 - Expansion vessel	150 - Backflow preventer	531 - DHW electrical backup safety thermostat
52 - Decoupling bottle	151 - Safety group	540 - Flow temperature sensor (combination circuit)
53 - Directional valve	152 - Thermostatic mixer	

- 2 heating circuits

HYDRAULIC UNIT

HYDRAULIC UNIT

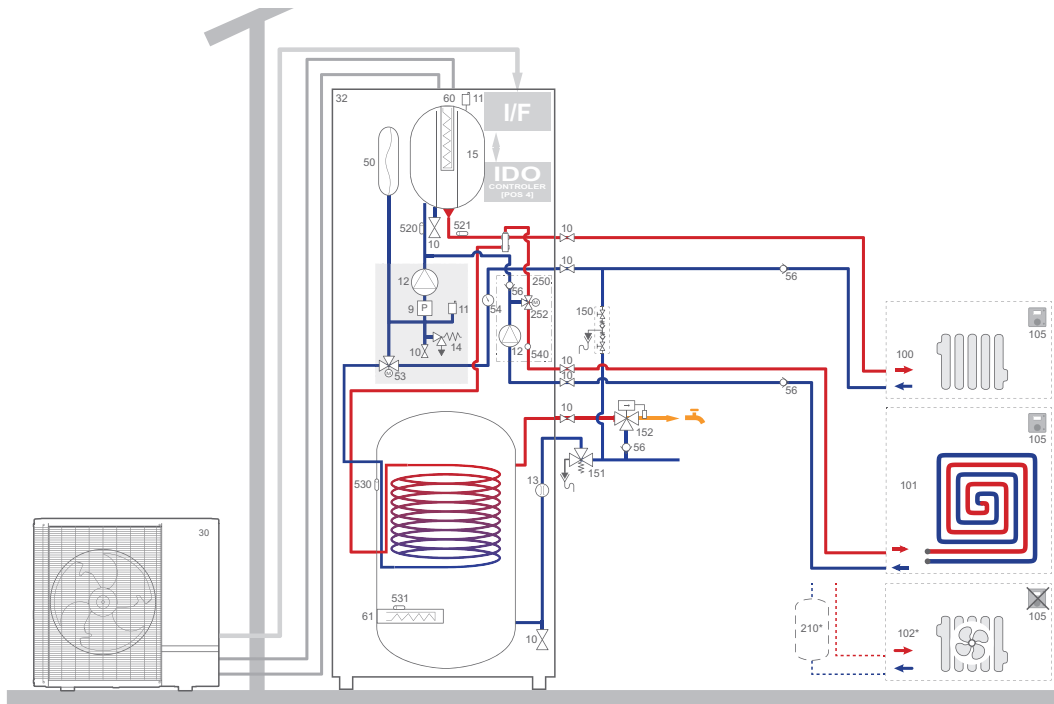

9 - Pressure sensor (Value)	56 - Non-return valve	210 - Buffer tank
10 - Valve	60 - Electrical heating backup	250 - 2-circuit kit
11 - Drain valves	61 - DHW electrical backup	251 - Combination circuit kit
12 - Circulation pump	100 - Radiator	252 - Mixing valve
13 - Flowmeter	101 - Underfloor heating system	520 - Return temperature sensor (heating circuit)
14 - Safety valve	102 - Dynamic radiator (fan convector)	521 - Flow temperature sensor (heating circuit)
32 - Dual hydraulic unit*	105 - Thermostat or room sensor (zone 1)	530 - DHW temperature sensor
50 - Expansion vessel	150 - Backflow preventer	531 - DHW electrical backup safety thermostat
52 - Decoupling bottle	151 - Safety group	540 - Flow temperature sensor (combination circuit)
53 - Directional valve	152 - Thermostatic mixer	



# 5-2. Model: WGEK140MQ9-19

HYDRAULIC UNIT

HYDRAULIC UNIT

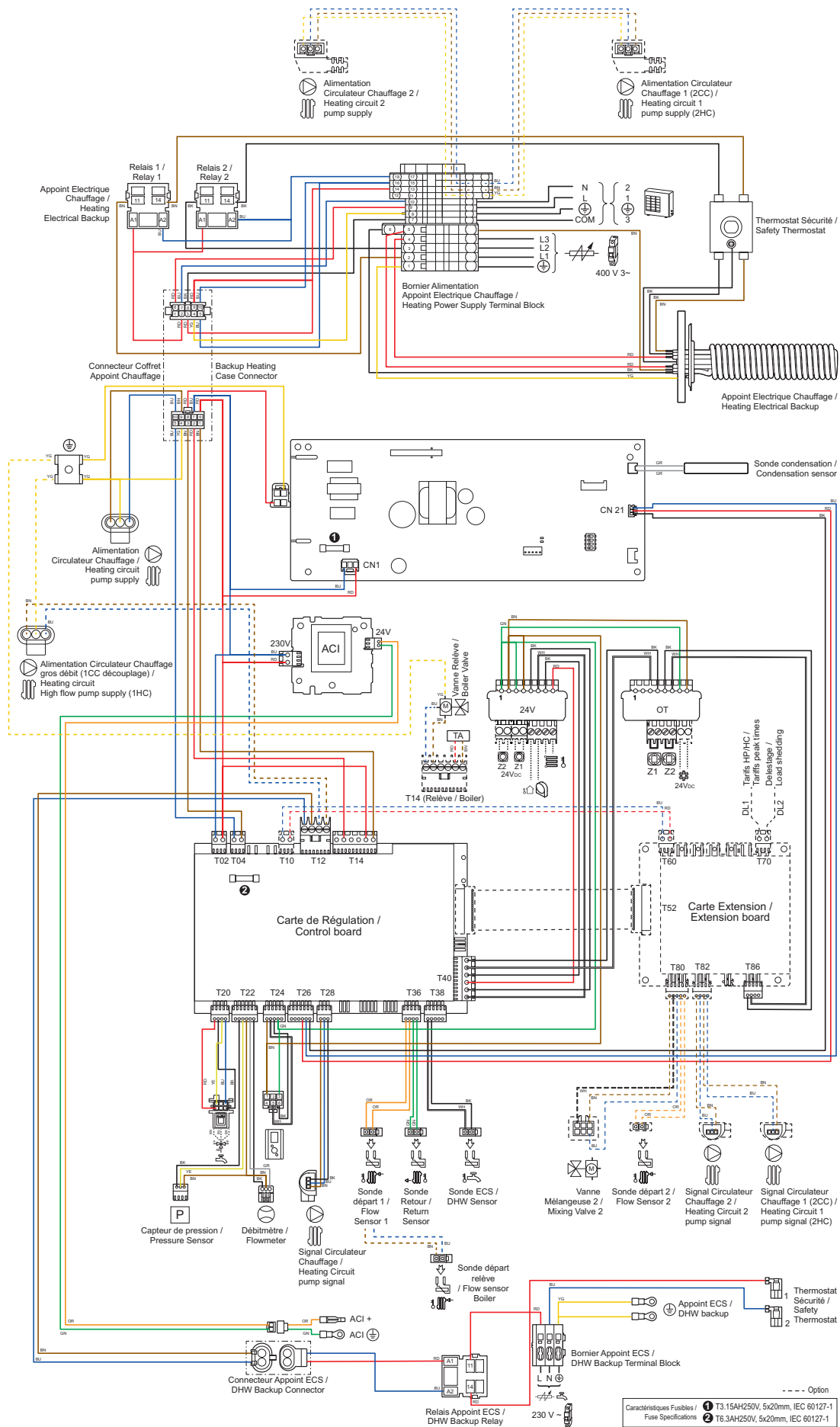

Caractéristiques Fusibles /	1	T3.15AH250V, 5x20mm, IEC 60127-1
Fuse Specifications	2	T6.3AH250V, 5x20mm, IEC 60127-1

## 6. Pipe connections

### 6-1. Hydraulic connections

Connect the pipe of the outdoor unit to the hydraulic unit respecting the direction of flow.

#### ⚠ CAUTION

- Install a sediment trap (supplied) on the heating return circuit in the manner suggested.
- Install antifreeze valves (optional/not supplied) on the hydraulic circuit in the recommended direction. If the antifreeze valves are triggered, check the electrical backup safety thermostat before restarting.

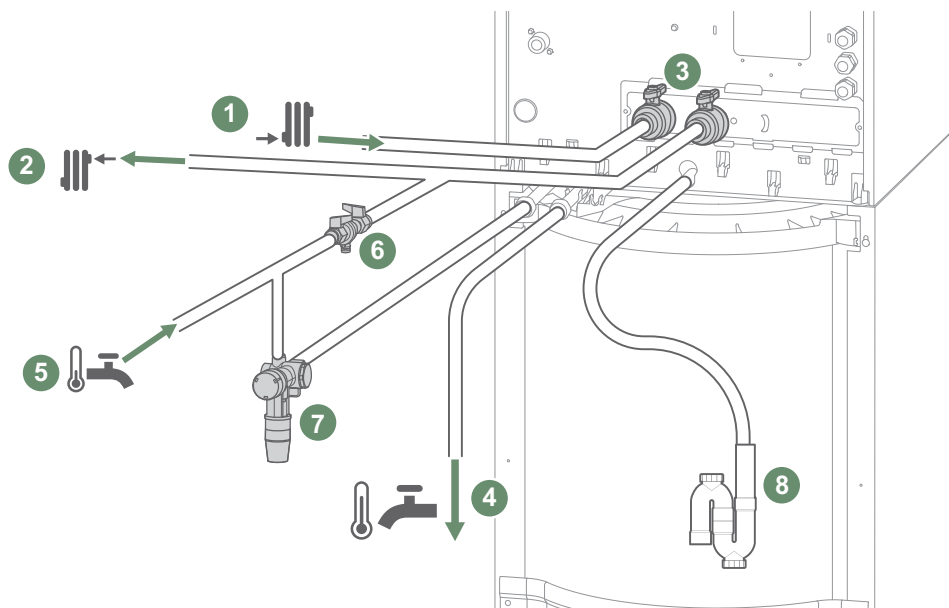

- |                                      |  |
|--------------------------------------|--|
| 1 - Heating return (1 circuit).      | 5 - DCW inlet (domestic cold water).         |
| 2 - Heating flow (1 circuit).        | 6 - Backflow preventer (not supplied).       |
| 3 - Shut-off valve (not supplied).   | 7 - Safety group (mandatory / not supplied). |
| 4 - DHW outlet (domestic hot water). | 8 - Drain pipe (to sewer).                   |

#### • Connection to the DHW circuit

Mandatory: Place a safety group on the cold water inlet with a 7 to 10 bar maximum calibrated valve (in accordance with local regulations), connected to a sewer drain. The exhaust must be kept open in the open air. The exhaust must be installed in a frost-protected environment, in a continuous downward slope.

Operate the safety group in accordance with manufacturer recommendations. There must be no valve between the safety group and the tank.

Connect the safety valve outlet to the sewer.

It is recommended to put a thermostatic mixer at the hot water outlet.

## 6-2. Refrigeration connections

- Length and diameters of hydraulic pipes

Maximum pipe length: 25 m

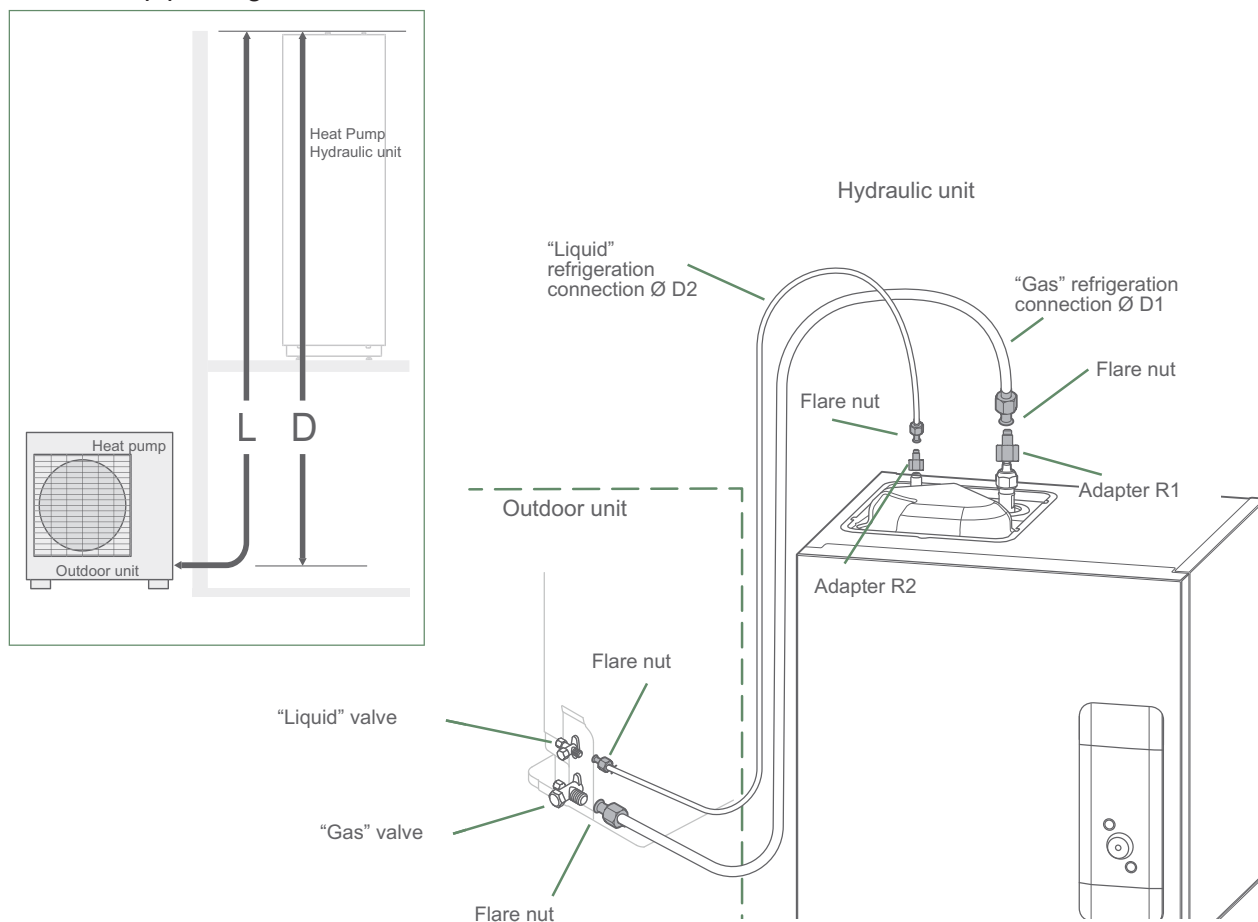

Outdoor unit fittings		Gas	Liquid
Refrigeration connections	Diameter	1/2	1/4
	Minimum length (L)		5 m
	Maximum length* (L)		15 m
	Maximum length** (L)		25 m
	Maximum drop** (D)		20 m
Adapter (reducer) male-female		1/2 - 5/8	1/4 - 3/8
Hydraulic unit fittings		5/8	3/8

\*: Without additional filling.

\*\* : Taking into account the potential additional filling.

# 7. Electrical connections

## 7-1. Overview

HYDRAULIC UNIT

HYDRAULIC UNIT

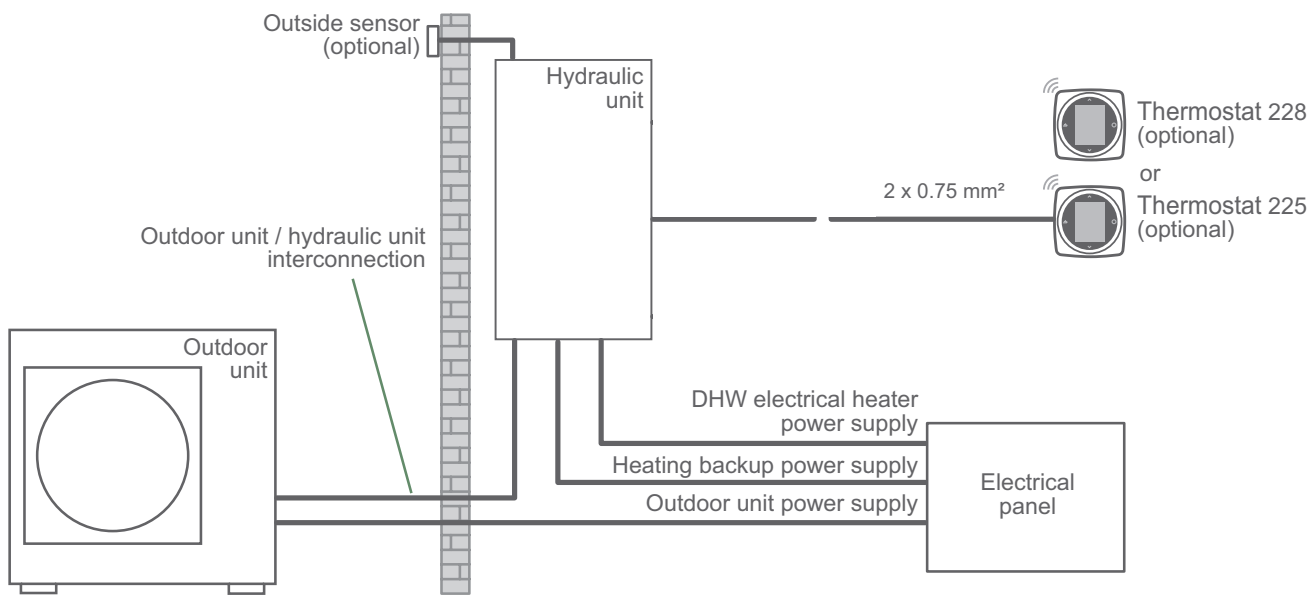

## 7-2. Cable dimensions and protection rating

- **Outdoor unit and hydraulic unit interconnection**

Follow the correspondence between the terminal block markers on the hydraulic unit and the outdoor unit when connecting the interconnection cables.

A connecting error may destroy one of the units.

- **Electrical heating backup**

Connect the power supply to the backup.

- **6 kW backup**

3G6 mm<sup>2</sup> cable minimum (phase, neutral, earth) up to the electrical panel. Protected by circuit-breaker [type C].

- **9 kW backup**

4G2.5 mm<sup>2</sup> cable minimum (3 phases, earth) up to the electrical panel. Protected by circuit breaker [type C].

- **DHW electrical backup**

Connect the power supply to the DHW electrical heater using a 3G1.5 mm<sup>2</sup> cable (phase, neutral, earth) up to the electrical pane. Protected by circuit-breaker [16 A type C]

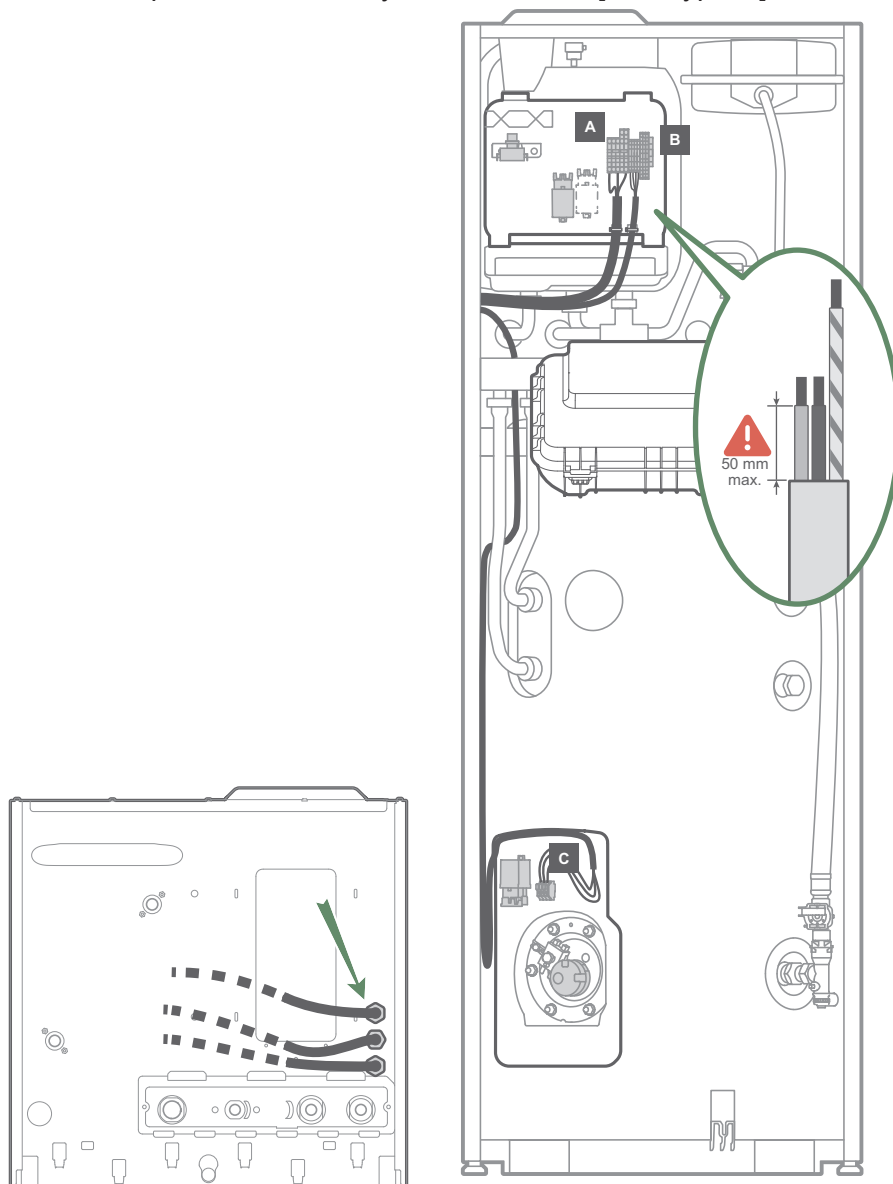

■ Electrical heating backup cabinet terminal  
Single-phase models

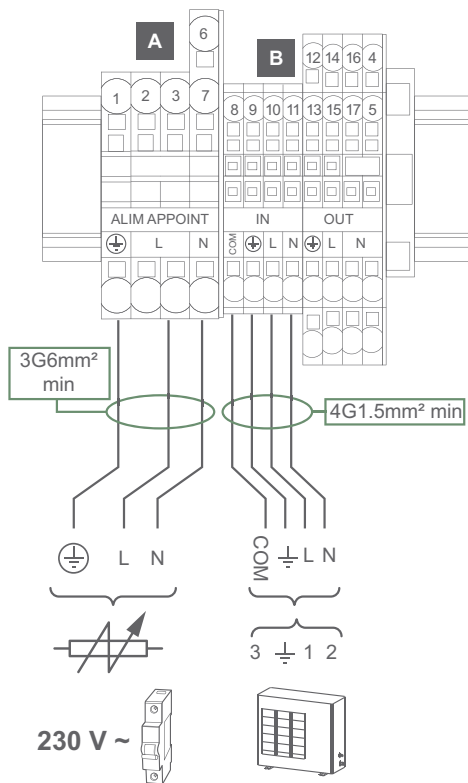

■ Electrical heating backup cabinet terminal  
Three-phase models

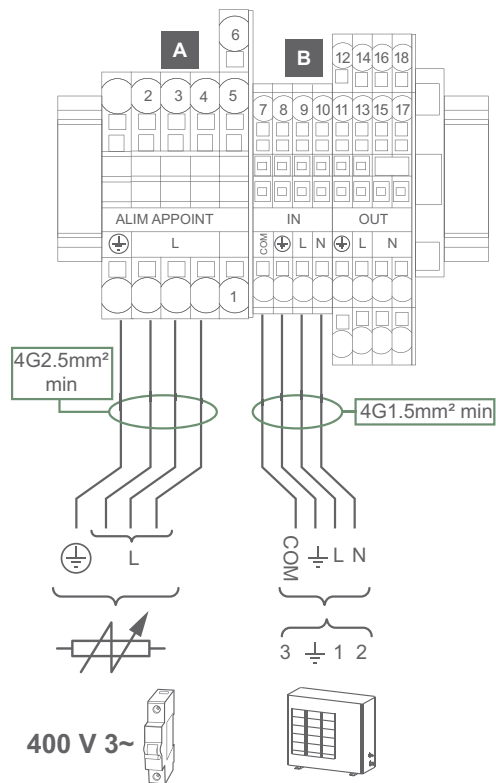

■ DHW power supply cabinet terminal

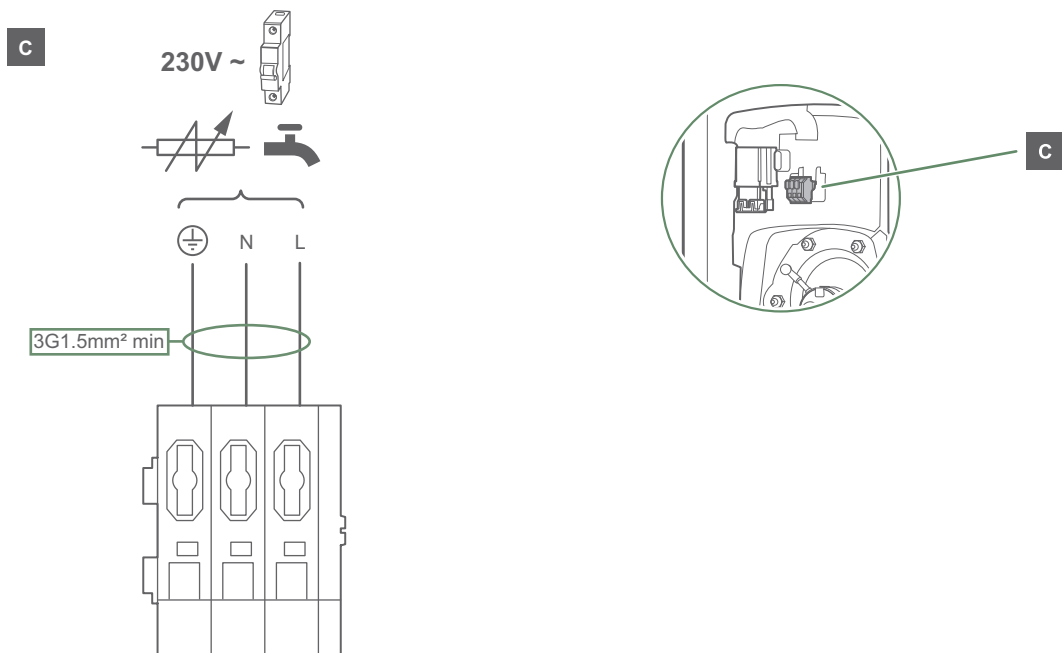

HYDRAULIC UNIT

HYDRAULIC UNIT

# 8. Hydraulic performance

## 8-1. Models: WGEK140MQ6-19 and WGEK140MQ9-19

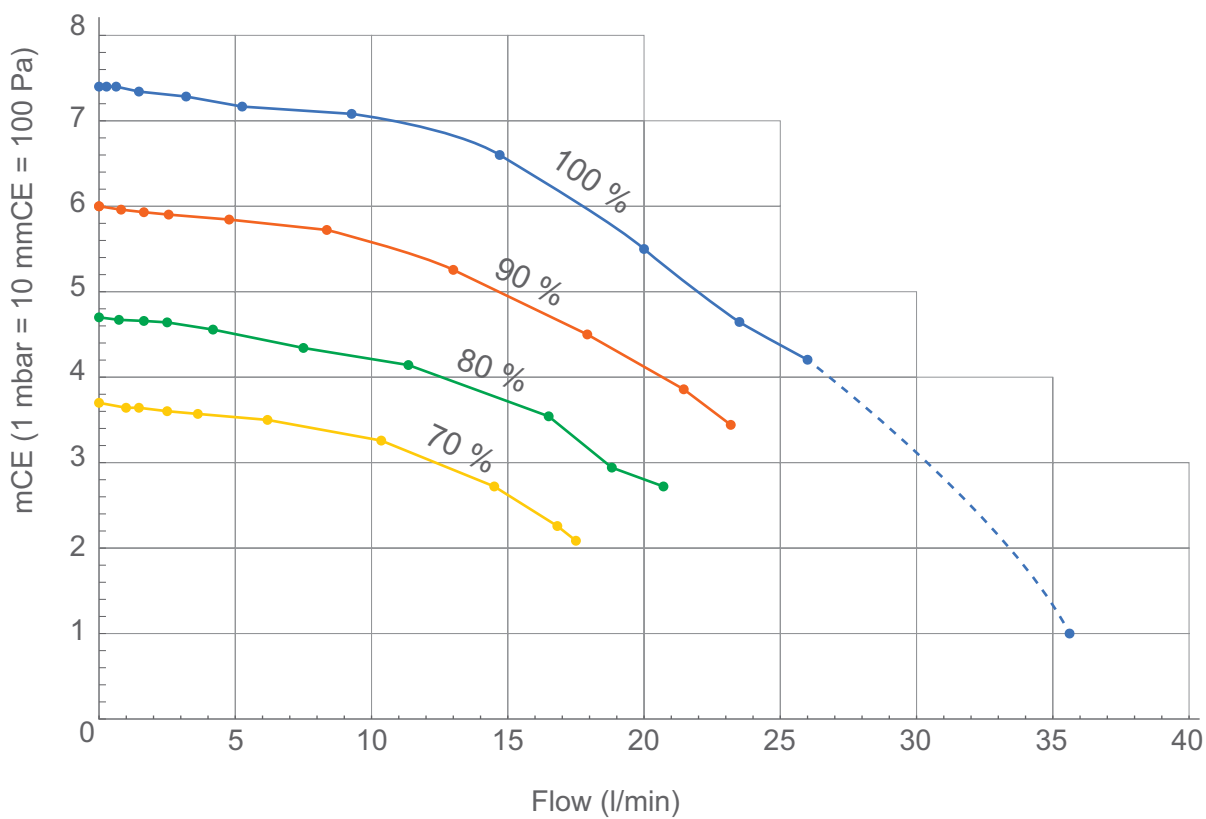

HYDRAULIC UNIT

HYDRAULIC UNIT









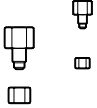

## 9. Safety devices

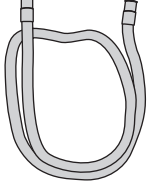
Type of protection	Protection form		Model
			WGEG140MQ6-19 and WGEK140MQ9-19
Circuit protection	Current fuse (PCB)		250 V, 3.15 A
			250 V, 6.3 A
High pressure protection	Safety valve	Activate	3 bar or more Safety valve open
		Reset	—

# 10. Accessories

HYDRAULIC  
UNIT

HYDRAULIC  
UNIT

Shape	Name
	<p>1/2" - 5/8" and/or 1/4" - 3/8" adapter, 1/2" and/or 1/4" nut</p>
	<p>Elbow</p>
	<p>Plugs X 9</p>
	<p>Drain pipe</p>
	<p>One contact gasket x2</p>
	<p>Rating label</p>
	<p>Packaging label</p>
	<p>Installation manual</p>
	<p>Quick installation manual</p>
	<p>FICHE</p>
	<p>Operation manual</p>



## 3. CONTROL SYSTEM

# CONTENTS

## 3. CONTROL SYSTEM

<b>1. User interface .....</b>	<b>03-1</b>
<b>2. Function table.....</b>	<b>03-3</b>
2-1. Flow setpoint .....	03-3
2-2. User menu .....	03-4
2-3. Installed options.....	03-5
2-4. Domestic Hot Water .....	03-7
2-5. Heating .....	03-8
2-6. Heat pump .....	03-9
2-7. Additional functions .....	03-10
2-8. Radio network.....	03-12
2-9. Diagnosis.....	03-13

# 1. User interface

CONTROL SYSTEM

CONTROL SYSTEM

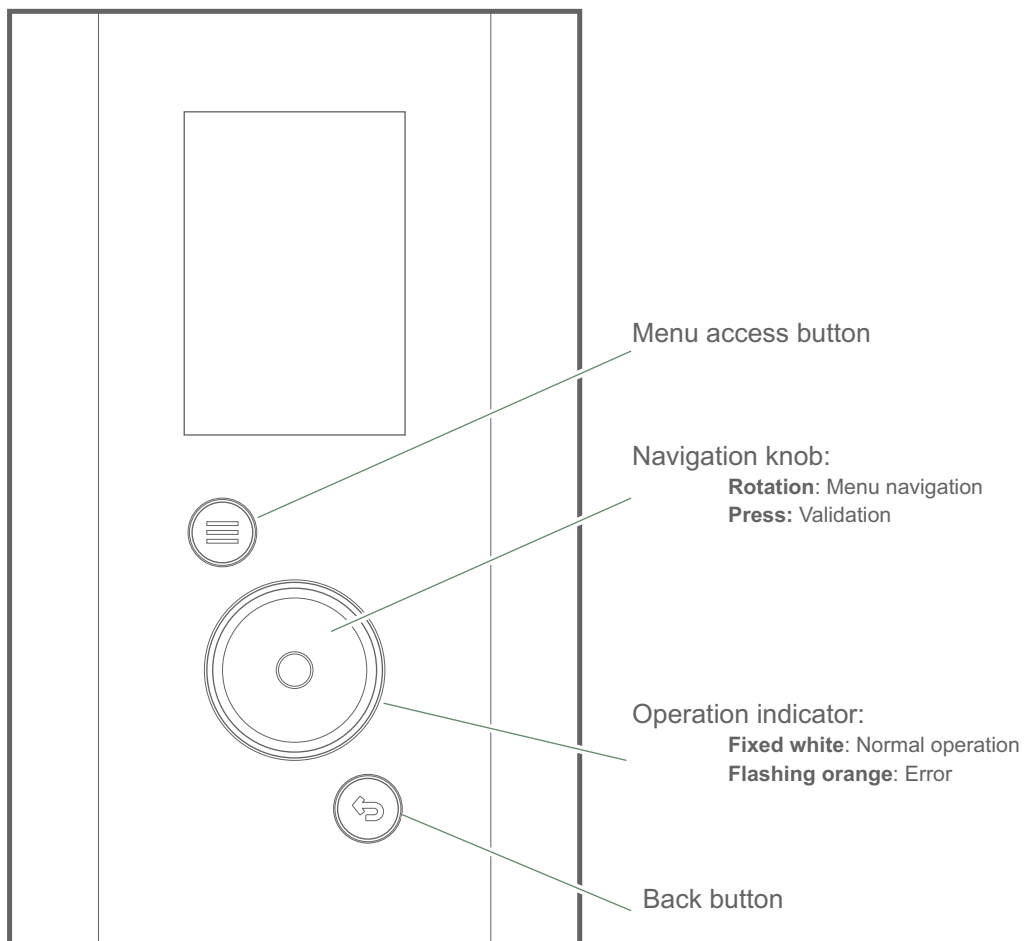

• Display description

- 1 Connectivity
- Attenuation mode
- Programmed away mode
- Emergency mode
- Outdoor temperature
- Installer menu

- 2 Normal operation
- Caution
- Error

- 3 Pressure indicator

- 4 55°C DHW setpoint

Quantity of hot water remaining

- 5 43°C Flow temperature setpoint

Operation:

- (Orange) Heating
- (Grey) Off / Frost protection

Mode:

- Heating
- Away Mode
- Floor drying mode

Produced by:

- Heat pump
- Electrical backup
- Heat pump + Electrical backup
- Heat Pump + Backup Boiler
- Backup Boiler

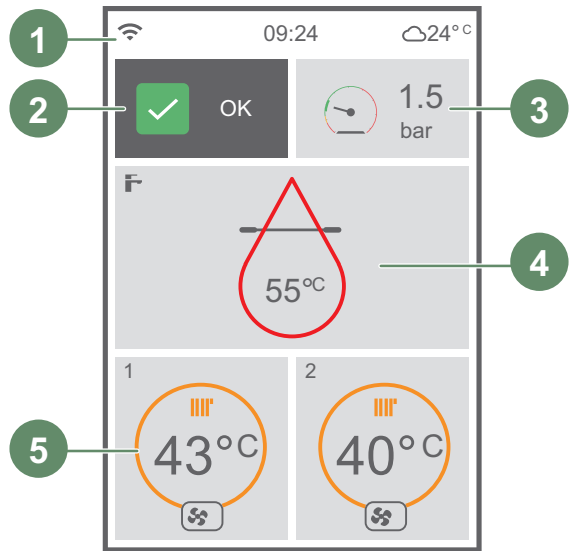

CONTROL SYSTEM

CONTROL SYSTEM

## 2. Function table

There are 2 access levels:

- U: End user level
- I: Commissioning level (installer start-up)

### 2-1. Flow setpoint

#### ► WITH a room thermostat

The heat pump operation is controlled by room thermostat.

The heating circuit water temperature setpoint is calculated by the thermostat and communicated to the heat pump.

	<b>Thermostat settings</b>
	<ul style="list-style-type: none"> <li>• Heating settings                     <ul style="list-style-type: none"> <li>- Mode selection.</li> <li>- Setting of room setpoints.</li> <li>- Setting of time slots.</li> </ul> </li> </ul>

#### ► WITHOUT a room thermostat

The heat pump operation is subject to temperature control.

The heating circuit water temperature setpoint is adjusted according to the outside temperature.

If the installation includes thermostatic valves, they must be open wide or set higher than the normal setpoint ambient temperature.

#### ▼ Setting

##### Setting the heating flow setpoint

Setting is done directly via the interface.

Heating	Circuit 1	Heating
---------	-----------	---------

Circuit 1 Heating	
Flow setpoint limits:	
Min.: 20°C	Max.: 50°C
Temperature control	
Temperature control	
Starting with outside T° -10°C	40°C
Starting with outside T° 20°C	20°C

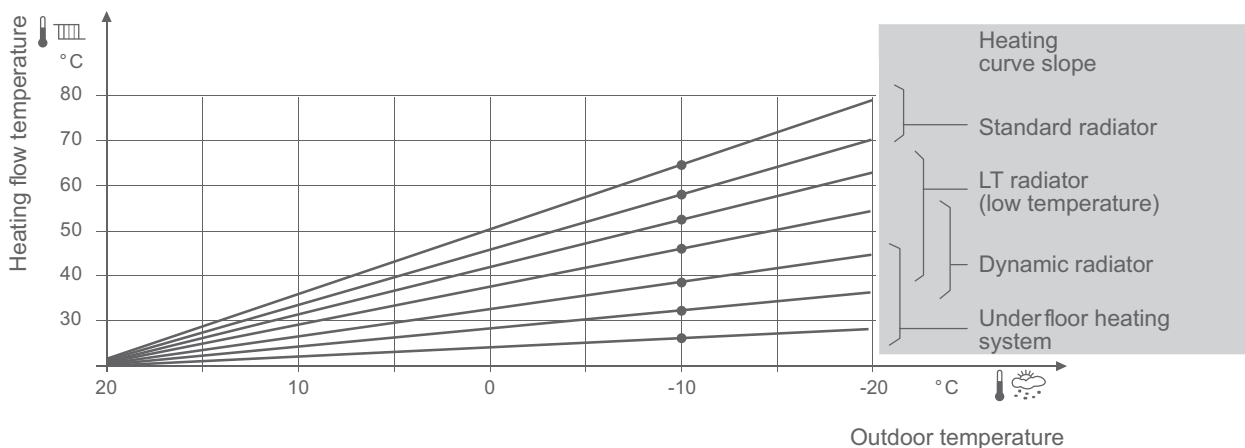

## 2-2. User menu

Access	Function		Setting range or Display	Setting increment	Factory setting
U	Active functions	Domestic hot water	On / Off	---	off
U		Circuit 1/2	On / Off	---	off
U		Emergency mode	Enabled / Inactive	---	inactive
U	Domestic hot water	Heating mode	comfort / eco	---	comfort
U		Temperature	45°C... 65°C	1	55
U	Away mode	Start	Start / End	---	---
U	Energy monitoring	Energy Consumed	For heating / For hot water / Total	---	0
U		Energy Produced	For heating / For hot water / Total	---	0
U	Language		---	---	---
U	Date/Time		---	---	---
U	Circuit names		---	---	---
U	Wi-Fi		---	---	---
U	Software version		---	---	---

- **Emergency mode**

If the heat pump is not operating properly, an emergency operation can be maintained. The emergency operation enables the installation to be run with the available heaters (flow, DHW tank). In this case, the compressor will remain off.

- **Away mode**

It will set heating and DHW mode to the frost protection\* during the selected period:

- If you activate away mode on HMI:  
You can choose start and end time/date
- If you activate away mode on Room thermostat (option):  
You can choose start and end time/date, as well as room setpoint during away period.

\*: The protection mode automatically prevents an excessively sharp drop in room temperature.

## 2-3. Installed options

Access	Function	Setting range or Display	Setting increment	Factory setting
	Outdoor Unit Model	-- kW ... 10 kW Single-phase... 12 kW Single-phase... 14 kW Single-Phase (single-phase unit) OR '-- kW ... 12 kW Three-phase... 14 kW Three-Phase (three-phase unit)	-	-- kW
	Electrical heater	None / 3 kW + 3 kW / 9 kW / Backup boiler	-	3kW + 3kW (single-phase) 9kW (three-phase)
	Number of circuits	1/2	-	1
	Circuit X: Name	Circuit 1 / Day / Night / Ground floor / Upper floor / Living areas / Bedrooms	-	Circuit 1
	Circuit X: Emitter Type	Radiators / Floor / Ceiling / Fan convector	-	Radiators
	Decoupling	Yes/No	-	No
	Outdoor temperature	From Outdoor unit / From remote sensor	-	Depending on sensor connection
	Safety input	Normally Open / Normally Closed	-	Normally open
	Ext. inlet 1: Type of features	None / Off -peak hours / PhotoVoltaics / Smart Grid	-	None
	Ext. inlet 2: Type of features	None / Power limitation	-	None
	Save	-	-	-

- **Outside temperature**

If UTW-KESXQ (option) is connected to indoor unit, 'From remote sensor' can be activated. UTW-KESXQ (option) is used in case the outside temperature from the outdoor unit is not representative. For example, The outside temperature can not be detected as current temperature because there is outdoor unit in a sunny spot.

• **Extension control board**

Refer to the instructions supplied with the extension control board.

It is possible to link the operating of the heat pump to specific contracts, in order to produce domestic hot water (DHW) during the cheapest hours:

– **Component location**

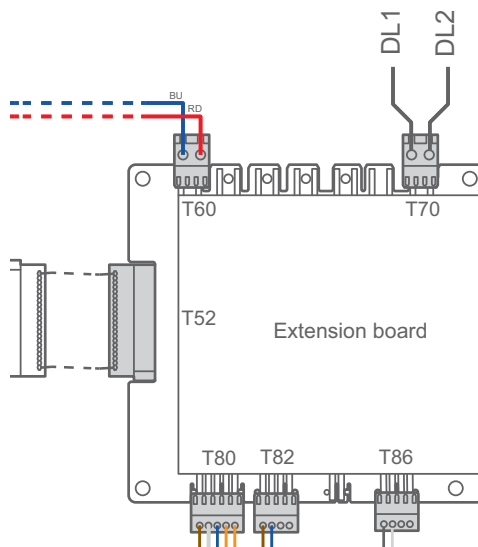

– **Function**

• **Off-peak hours**

- Connect the “Energy supplier” contact to the DL1 inlet of the T70 connector.
- In the Installed Options menu, set the line “Ext. inlet 1: Type of features” to “Off -peak hours”.
- By default: 230 V on DL1 = information “Off -peak hours” activated”.
- the production of DHW is done at the comfort setpoint.

• **PhotoVoltaics**

- Connect the “Energy supplier” contact to the DL1 inlet of the T70 connector.
- In the Installed Options menu, set the line “Ext. inlet 1: Type of features” to “PhotoVoltaics”.
- By default: 230 V on DL1 = information “Photovoltaics” activated”.
- the hot water tank electrical backup is activated up to 65°C.

• **Power limitation or EJP (Peak tariff days)**

- Connect the power balancer to the DL2 input of the T70 connector.
- In the Installed Options menu, set the line “Ext. inlet 2: Type of features” to “Power limitation”.
- By default: 230 V on DL2 = power limitation in progress the heat pump backups and DHW electrical heater are off . The heat pump is authorised or stopped according to the setting “If instruction for Erasure/Power limitation”.

• **Smart Grid**

- Connect the 2 power contacts “Power suppliers” to inputs DL1 and DL2 of connector T70.
- Set the “External input 1: Type of functions” to “Smart Grid” in the menu “Installed Options”.
- By default: Smart grid operation is as follows.

DL1	DL2	Behavior
0 V	0 V	Normal
230 V	0 V	Same as Power limitation
0 V	230 V	Same as Off -peak hours
230 V	230 V	Activation of DHW boost

## 2-4. Domestic Hot Water

Access	Function	Setting range or Display	Setting increment	Factory setting	
I	On a daily basis	Heating mode	Eco / Comfort	-	Comfort
I		Temperature	47°C ... 55°C ... Max. temperature	1	55
I		Max. temperature	Temperature... 65°C	1	65
I		Forced load	Auto/Manual	-	Auto
I		Forced load 1 / 2	Set time	-	Forced load 1 : 14h00 Forced load 2 : --
I	Antilegionella	Weekly protection	Enabled/Inactive	-	Inactive
I		Time of cycle	Set day and time	-	Friday at 3am
I		Temperature	45°C... 60°C ... 65°C	1	60

- **Anti-Legionella**

The indoor unit has a legionella function designed for protection against legionella in the storage tank and the pipes.

The legionella function can be activated on a fixed day of the week.

With this setting, heating up to the legionella setpoint occurs on the scheduled day of the week, regardless of the storage tank temperatures during the previous period.

## 2-5. Heating

Access	Function		Setting range or Display	Setting increment	Factory setting
	Heating Circuit 1	Flow setpoint limits	Min.: 20°C... 30°C Max.: 30°C... 80°C	1	Depending on emitter type
		Temperature control	Temperature control	-	Temperature control If Navilink thermostat : Smart Adapt
		Starting with outside T° -10°C	Starting with outside T° 20°C... 65°C... 80°C	1	Depending on emitter type
		Starting with outside T° 20°C	10°C... 20°C... Starting with outside T° -10°C	1	Depending on emitter type
	Heating Circuit 2	Flow setpoint limits	Min.: 20°C... 30°C Max.: 30°C... 80°C	1	Depending on emitter type
		Temperature control	Temperature control	-	Temperature control If Navilink thermostat : Smart Adapt
		Starting with outside T° -10°C	Starting with outside T° 20°C ... 35°C... 80°C	1	Depending on emitter type
		Starting with outside T° 20°C	10°C ... 20°C... Starting with outside T° -10°C	1	Depending on emitter type
		Mixing valve correction	0°C ... 20°C	1	0

- **Starting with outside T° -10°C, Starting with outside T° 20°C**

Heating curve slope in weather compensation will be affected by setting these parameters.

It is calculated with a linear function between two points (-10°C and 20°C).

## 2-6. Heat pump

Access	Function	Setting range or Display	Setting increment	Factory setting	
	Compressor	Minimum off time	3 min. ... 8 min. ... 20 min.	1	8
		Overrun	10 s ... 30 s ... 600 s	10	30
	DHW production	Max. DHW charging time	90 min. ... 120 min. ... 180 min.	10	120
		Heating / Cold return	10 min. ... 90 min. ... 180 min.	10	90
	Electrical heater	Allowed if outside T° <	Always allowed / -15°C ... 2°C ... 10°C	1	2
		Switching threshold	0°C min. ... 100°C min. ... 500°C min.	10	100
	Heat pump / boiler switch	Minimum time HP	5 min ... 30 min ... 60 min	5	30
		HP forbidden if outside T° <	-15°C... -2°C... 10°C / Always allowed	1	-2
		Boiler allowed if outside T° >	-15°C... 2°C... 10°C / Always allowed	1	Always allowed
		Switching threshold	0°C min. ... 100°C min. ... 500°C min.	10	100
	Circulation pumps	System pump speed	30% ... 100%	10	100
		Circulation pump speed Circuit 2	50% ... 100%	10	100

### • Compressor

#### – Minimum off time

The compressor remains switched off for the minimum period of time set here. Switch-off temperature maximum if the flow or the return temperature exceeds the maximum switch-off temperature, the compressor will be switched off. The heat pump is switched on again when the temperature at both sensors has dropped by the “Switching difference return temperature” below the maximum switch-off temperature and the minimum off time has elapsed.

#### – Overrun

Overrun time is about all the pumps keep running this overtime after compressor stops.

### • DHW production

#### – Max. DHW charging time

During charging, the room heating may be stopped or insufficient. Therefore it is often advisable to limit the charging process timewise to enable heating. If “---” has been selected the charging time limitation will be deactivated. The DHW will be heated to the nominal setpoint, even if the room heating has not received enough power in the meantime. If a value between 90 and 180 is selected, charging will be suspended after the time period set in minutes, and will remain suspended over that time before resuming. The generator power remains available in the meantime to heat the room. This cycle is repeated until the DHW nominal setpoint has been reached.

**NOTE:** When the room heating is stopped (summer mode, economy function, etc.), DHW charging remains active, regardless of the setting.

#### – Heating/Cold return

If “Back to Heating/Cooling” time has elapsed, then DHW operation is resumed.

## 2-7. Additional functions

Access	Function		Setting range or Display	Setting increment	Factory setting
	Attenuation mode	Compressor limitation	Enabled / Inactive	-	Active
		Max. allowed speed	10% ... 60% ... 95%	5	60
		Active as	Outside T° > -15°C ... 5°C ... 10°C	1	5
		Period 1	-- ... 00h00 ... 23h45	0:15	00h00 - 12h00
		Period 2		0:15	12h00 - 00h00
		Period 3		0:15	--
	Air purge cycle		-	-	-
	Floor drying mode Circuit 1 / 2	Drying	Off/Manual for 25 days / Progressive 18d + Shock 7d / Shock 7d + Progressive 18d / Progressive 18d / Shock 7d	-	Off
		Flow temperature	20°C... 25°C ... 55°C	1	25

- **Attenuation mode**

This function can limit compressor modulation for low noise.

**Example:**

- Compressor limitation: Enabled
- Max allowed speed: 50%
- Active as: Outdoor > -5°C (current outdoor temp = 0°C)
- Period 1: from 22:00 to 5:00

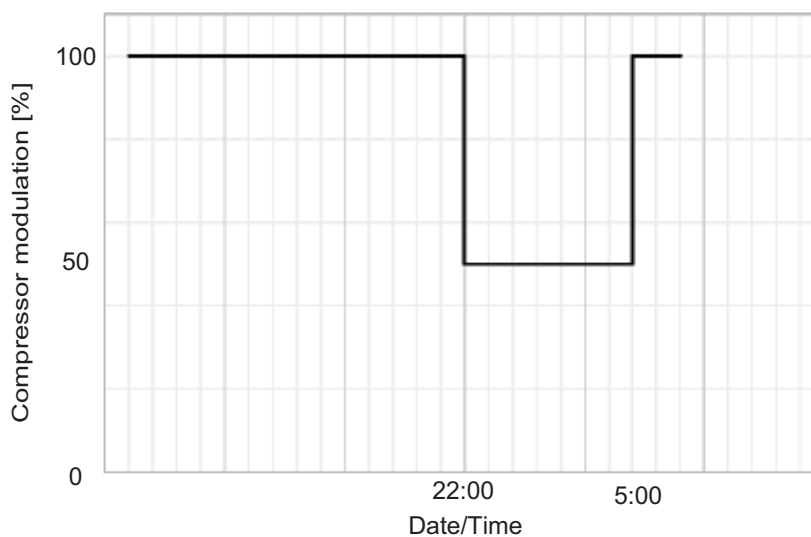

- **Air purge cycle**

The air purge cycle takes approximately 4 minutes.

Never interrupt this cycle.

(During the purge cycle, the circulator alternates between operating and stopping phases lasting 5 seconds (5 s on, 5 s off...).

The valve alternates every 30 seconds between the heating and sanitary circuits.)

Open all system drains to evacuate air from the pipes.

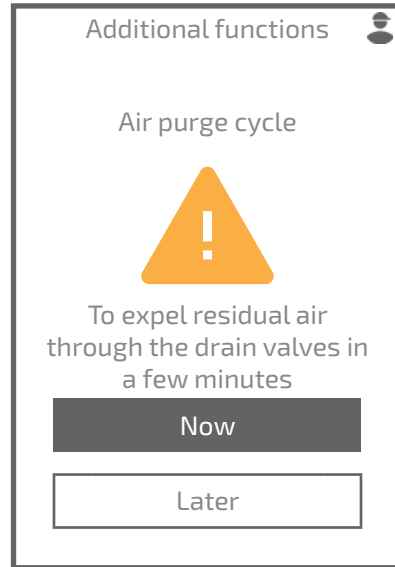

- **Floor drying circuit 1**

Observe the building manufacturer's standards and instructions. Correct operation of this function is only possible with a correctly installed system (Hydraulics, Electricity, and Settings).

The function can be interrupted early by setting to Off.

**NOTE:** This function is only usable with an underfloor heating system.

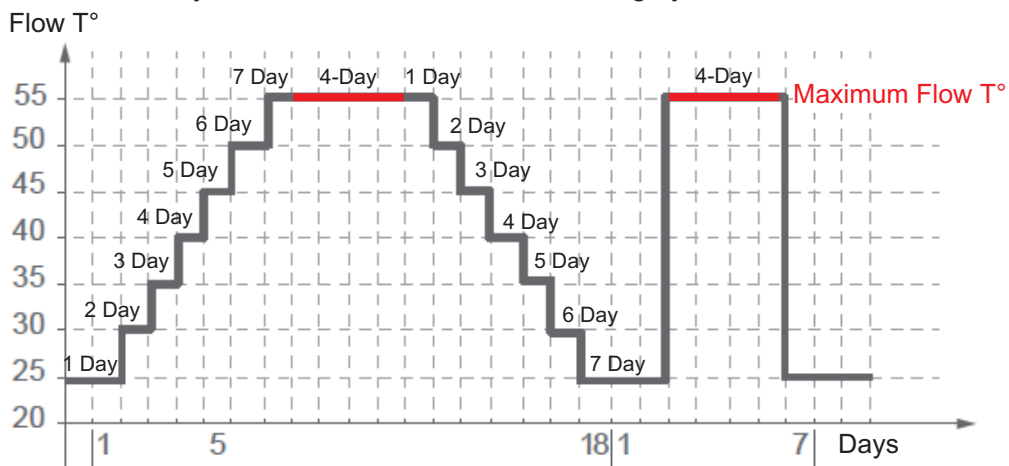

- A 28-day cycle is initiated for the floor drying process.
- 18 Days progressive.
- The water temperature will incrementally rise by 5°C each day, reaching 50°C on day 7.
- The temperature is maintained at 55°C for 4 days.
- Subsequently, there will be a gradual decrease of 5°C per day for 7 days, reaching 25°C.
- A new 7-day cycle will commence.
- The temperature will be raised to 55°C in a single step.
- This temperature will be maintained for 4 days.
- Subsequently, the temperature will return to 25°C.
- Progressive for 18 days, followed by a 7-day intensive treatment.

## 2-8. Radio network

Access	Function	Setting range or Display	Setting increment	Factory setting
	Add Thermostat	---	---	---
	Add Repeater	---	---	---
	Advanced Commands	Zigbee code	---	---
		Features	---	---
		Add another device	---	---
	Reset Network	---	---	---

- **Add thermostat**

For details, refer to the thermostat manuals for the following optional parts.

- UTW-C225XQ
- UTW-C228XQ

- **Add Repeater**

Install a radio repeater halfway between this control box and the thermostat.

**NOTE:** For the radio repeater, use the ATLANTIC product (Model: 139117) or equivalent (Locally purchased).

- **Advanced Controls: Features**

Provides status and the technical information on the radio network.

## 2-9. Diagnosis

Access	Function	Setting range or Display	Setting increment	Factory setting	
	Error history		-	-	
	Indoor unit		-	-	
	Outdoor unit		-	-	
	Outdoor unit test	Compressor modulation	Off / 7% ...100%	1	Off
		Directional valve	Heating position / Middle position / DHW position	-	Heating position
		System pump	Off / 30% ... 100%	-	Off
		System pump flow	---	-	-
		Flow temperature		-	-
		Return temperature		-	-
		Exchanger temperature		-	-
		Tank temperature		-	-
		Flow temperature Circuit 2		-	-
		Actuators test	System pump	Off / 30% ...100%	10
	System pump flow		---	-	-
	Electrical heater		Off / On	-	Off
	Flow temperature			-	-
	Return temperature			-	-
	Circulation pump speed Circuit 2		Off / 10% ...100%	10	Off
	Mixing valve Circuit 2		Closed / 10% ...100%	10	Closed
	Flow temperature Circuit 2			-	-
	DHW electrical heater		Off / On	-	Off
	Directional valve		Heating / Middle position / Domestic Hot Water	-	Heating
	Tank temperature		-	-	
	Operation counters		-	-	
	Serial numbers		-	-	
	Factory reset	-	-	-	

- **Actuator test**

These parameters are set to OFF the moment you leave the page or after 30 min without any action on the HMI.